

Engineering Standard

SAES-J-607

14 November 2005

Burner Management Systems for SRU Trains

Instrumentation Standards Committee Members

Al-Awami, L.H., Chairman

Tuin, R.R., Vice Chairman

Al-Dakhil, T.K.

Al-Dhafeeri, F.T.

Al-Khalifa, A.H.

Al-Madhi, F.A.

Alqaffas, S.A.

Bogusz, Z.J.

Ell, S.T.

Fadley, G.L.

Falkenberg, A.R.

Gawargy, N.E.

Grainger, J.F.

Jumah, Y.A.

Mahmood, B.

Qarni, M.A.

Trembley, R.J.

Saudi Aramco DeskTop Standards

Table of Contents

1	Scope.....	2
2	Conflicts and Deviations.....	2
3	References.....	2
4	Definitions.....	3
5	General Requirements.....	5
6	BMS – Hardware Requirements.....	6
7	BMS – Logic Requirements.....	7
8	Pilot System.....	10
9	Burner System.....	12
10	Flame Monitoring System	14
11	Control Room and Local BMS Interface.....	16
12	Installation.....	17
13	Documentation.....	18
14	Inspection and Testing.....	18
	Figure 1: Pilot Gas System Diagram.....	20
	Figure 2: Burner Gas System Diagram.....	21

1 Scope

- 1.1 This engineering standard establishes minimum requirements for the design, construction and installation of burner management systems (BMS) for the gas fired equipment in sulfur recovery unit (SRU) trains. SRU trains have typically 5 independently fired furnaces. The BMS system for each fired furnace is defined herein.
- 1.2 Emphasis is placed on the use of a reliable Burner Management System (BMS), incorporating flame monitoring, safety interlocks, light-off and purge permissives, and alarms and trip functions as defined in NFPA 85. Requirements of NFPA 85 shall be applied to the BMS systems used on SRU trains. However, conflicting requirements specified in this standard shall take precedence over NFPA 85.
- 1.3 A BMS is considered a specific type of Emergency Shutdown System (ESD). As such, all requirements of SAES-J-601 apply to this standard, except as noted herein.
- 1.4 The BMS requirements specified in this standard are considered prescriptive and the application of ANSI/ISA-84.00.01-2004 (IEC 61511 Mod), including establishment and validation of SIL levels, is not required.
- 1.5 This standard specifies the minimum BMS requirements for new SRU projects. BMS upgrade projects to existing SRU trains may reduce the minimum requirements of this standard to maintain consistency with other SRU units, when approved by the Saudi Aramco Proponent Organization.

2 Conflicts and Deviations

- 2.1 Any conflicts between this Standard and other applicable Saudi Aramco Engineering Standards (SAES's), Materials System Specifications (SAMSS's) Standard Drawings (SASD's), or industry standards, codes, and forms shall be resolved in writing by the Company or Buyer Representative through the Manager, Process and Control Systems Department, Dhahran.
- 2.2 Direct all requests to deviate from this standard in writing to the Company or Buyer Representative, who shall follow internal company procedure SAEP-302 and forward such requests to the Manager, Process and Control Systems Department, Dhahran.

3 References

The latest edition or revision of the following standards, specifications, codes, forms, and drawings shall, to the extent specified herein, form a part of this standard.

3.1 Saudi Aramco References

Saudi Aramco Engineering Procedure

SAEP-302 Instructions for Obtaining a Waiver of a Mandatory Saudi Aramco Engineering Requirement

Saudi Aramco Engineering Standards

SAES-F-001 Process Fired Heaters

SAES-J-002 Technically Acceptable Instruments

SAES-J-003 Basic Design Criteria

SAES-J-601 Emergency Shutdown and Isolation Systems

SAES-J-902 Electrical Systems for Instrumentation

Saudi Aramco Materials System Specifications

04-SAMSS-051 Ball Valves, (API SPEC 6D)

34-SAMSS-617 Flame Monitoring Systems

34-SAMSS-623 Programmable Controller Based ESD Systems

34-SAMSS-716 Pneumatic Actuators On-Off Service

3.2 National and Industry Standards

National Fire Protection Association

NFPA 85 Boiler and Combustion Systems Hazards Code

4 Definitions

Automatic BMS Operation: The Saudi Aramco mandatory method of BMS operation in which pushbutton actuations initiate furnace start-up, and where all purging, positioning, timing, and fuel/air valve manipulations are supervised and occur automatically. In Automatic BMS logic, operators are not required to manipulate burner front controls (e.g., manually open gas cocks) to light burners or pilots. Instead, burner and pilot starts are actuated from pushbuttons and monitored locally and remotely. Saudi Aramco requires the operator to manually initiate (via pushbutton) each of the following sequences:

- Furnace Master Fuel Trip (MFT) reset
 - Purge
 - Initial pilot/burner start (local operator function)
-

- Subsequent pilot/burner starts and stops
- Normal shutdown

Burner Valve (BV): A burner valve (BV) can be either an automated block valve or an automated bleed valve as defined below. BVs shall be selected as ZV valves per SAES-J-601; however, BVs shall not be provided with manual operators, local pushbutton operators, bypass valves, or partial stroke testing features. BVs are under complete control and supervision of the BMS system.

- **Automated Bleed Valve - BV:** This is an automatic valve used to vent fuel gas from between block BVs in both the pilot and burner fuel headers. Bleed valves shall be tagged as 'BV', and are not to be tagged as ZV.
- **Automated Block Valve - BV:** Sometimes called block valve, fuel shutdown valve, or SSV valve. The block valve is an automatic, fast closing, tight shutoff valve that completely shuts off fuel or air supply. These valves are located in the pilot and burner fuel headers and in the individual pilot and burner piping. Block valves can be used in conjunction with Bleed valves for gas service. Block valves shall be tagged as 'BV' and are not to be tagged as ZV.

Burner Management System (BMS): The BMS is the control system dedicated to furnace safety and provides operator assistance in the starting and stopping of fuel preparation and burning equipment. Use of a BMS prevents misoperation of and damage to fuel preparation and burning equipment. The BMS includes the following subsystems:

- Logic System
- Field Sensors
- Pilot System
- Flame Monitoring System
- Automated Block and Bleed Valves
- Local Flame Safety Shutdown Panel
- Control Room Indication and Control Equipment

Master Fuel Trip: Sometimes called main fuel trip or MFT; an event that results in the rapid shutoff of all fuel to a furnace.

Sulfur Recovery Unit (SRU) Fired Equipment: SRUs may have the following fired equipment:

- Air Preheater – A natural draft, fuel gas fired furnace that preheats combustion air to be used in the SRU Reaction Furnace. This furnace typically uses up to 10 burners
-

and incorporates continuous pilots. Pilots and burners are individually supervised, each with its own flame monitor. Pilots are lit via integrated spark ignitors. Firebox purging is via steam injection.

- Acid Gas Preheater – A natural draft, fuel gas fired furnace that preheats H₂S acid gas before it is combusted in the SRU Reaction Furnace. This furnace typically uses up to 14 burners with continuous pilots. Pilots and burners are individually supervised, each with its own flame monitor. Pilots are lit via integrated spark ignitors. Firebox purging is via steam injection.
- Reaction Furnace - A forced draft reaction furnace with one burner (typically no pilot) where acid gas is the fuel and is burned with air to form SO₂ and sulfur. This furnace will also be equipped with a forced draft fuel gas fired burner that starts and supplements the H₂S burning. The fuel gas burner flame is lit by an automatically retracting spark ignitor. The burner flame is supervised with dual optical flame monitors. Purging on cold start is by combustion air flow, but on hot re-start, purge is via nitrogen to prevent reactor cool-down and free oxygen ingress to the downstream catalyst beds.
- Catalytic Reheat-Auxiliary Combustion Chamber/Burner – When used, the auxiliary combustion chamber uses a single forced draft, fuel gas or fuel gas/acid gas fired burner to reheat the process stream above the liquid sulfur dewpoint prior to entering the next catalytic conversion stage. This burner is supervised with dual flame monitors and is lit by an automatically retracting spark ignitor (typically no pilot). There are up to 3 independent Catalytic Reheat Auxiliary Combustion Chamber/Burners per Reaction Furnace. Purge is via forced draft combustion airflow.
- Tail Gas Thermal Oxidizer – A natural or forced draft, fuel gas fired furnace that combusts the SRU tail gas to form SO₂ and release to atmosphere. The Thermal Oxidizer uses multiple burners with continuous pilots. Pilots and burners are individually supervised, each with their own flame monitor. Pilots are lit via integrated spark ignitors. Firebox purging is via steam injection or air in the forced draft configuration.

5 General Requirements

- 5.1 Each SRU furnace shall have automatic BMS logic. Each BMS system shall incorporate a complete automatic BMS sequence including:
- Pre-Purge Permissives
 - Purge
 - Light off First and Subsequent Pilots and Burners
-

- Normal Operation
- Individual Pilot Fuel and/or Burner Fuel Trips
- Total Furnace Master Fuel Trips

5.2 Instrument Selection

Instruments shall be selected from SAES-J-002.

5.3 Environmental Conditions

All equipment shall be specified, built and installed for operation in environmental conditions per SAES-J-003.

6 Burner Management System – Hardware Requirements

6.1 BMS Electrical Requirements

6.1.1 The electrical installation shall be designed and installed per requirements specified in SAES-J-902.

6.1.2 All BMS logic hardware and subsystems shall be powered from uninterruptible power supplies (UPS), as specified in SAES-J-902 and SAES-J-601.

6.2 BMS System

6.2.1 Logic Solver Hardware Types

Programmable logic controllers (PLCs) which are approved for use in ESD systems, as specified in 34-SAMSS-623, shall be used for BMS logic hardware.

6.2.2 Logic Software Modification Limitation

BMS logic software shall not be changed while its associated fired equipment is in operation.

6.2.3 Logic Hardware Segregation

6.2.3.1 All BMS and ESD logic from a single SRU train shall be integrated into a dedicated PLC logic hardware package.

6.2.3.2 No other BMS, ESD, or non-ESD logic shall be included in the SRU train's dedicated BMS PLC hardware.

6.3 BMS Field Instruments

6.3.1 Input Sensors

6.3.1.1 Process measurement input signals to the BMS shall be from process connected transmitters, as defined in SAES-J-601. Discrete BMS inputs may be from hardwired manual push/pull buttons or dry contact inputs from valve position switches and flame scanner/amplifier relays.

6.3.1.2 All input sensors and associated signal wiring shall meet the requirements specified in SAES-J-902.

6.3.2 Output Solenoids

Solenoid valves shall have high temperature, class H insulated coils, internal valve trim appropriate for the service, and be suitable for continuous duty. They shall meet requirements specified in SAES-J-902.

6.3.3 Input/Output Bypasses

6.3.3.1 Input bypasses shall be provided for each Master Fuel Trip (MFT) input to the BMS. The input bypasses shall meet the requirements of SAES-J-601. Note that the use of input bypasses is limited to online testing and maintenance only. Startup bypasses are not permitted.

6.3.3.2 Output bypasses shall not be used.

7 Burner Management System – Logic Requirements

7.1 BMS Startup Logic Sequence

7.1.1 An automatic BMS sequence, as defined in section 4 above, shall be used for each fired furnace in the SRU train.

7.1.2 The BMS shall supervise each step in the light-off sequence, including pre-purge permissives, purge and fuel gas tightness testing, pilot and burner light-off, normal operation, and shutdown.

7.1.3 The purge process shall be manually initiated via pushbutton in the field, with the intent that the field operator will verify purge operation.

7.1.4 Purge shall accomplish 5 furnace volume air changes with a purge time of least 5 minutes. Forced draft furnaces shall incorporate airflow meters to verify purge rate. Natural draft furnaces shall incorporate an active

method to generate airflow (e.g., steam purge). The furnace designer shall verify by calculation that the design purge airflow rate and time meet the required 5 furnace volume changes. Natural draft furnace purge airflow rate shall be confirmed by a one-time test conducted during furnace commissioning. Natural draft heaters shall incorporate a manual combustible gas test as part of the purge sequence.

- 7.1.5. A pilot and burner fuel gas piping leak test shall be included in the purge sequence for all multiburner furnaces. Fuel gas at a normal pressure shall be introduced to the both pilot and burner headers up to the individual pilot and burner BVs. Header block BVs shall then be closed and the bleed BV opened, and the individual pilot and burner BVs shall be closed. The trapped fuel pressure shall be monitored for 3 minutes and any significant pressure loss shall invalidate the purge, shall require shutoff valve leak investigation and repair, and shall take the sequence back to the purge required state. The manual isolation valve and blind on the individual burners and pilots shall be open during the leak test. See Figure 1 and 2 for diagrams of the fuel gas systems. The furnace designer shall calculate the acceptable leak test pressure drop based on the BV valve leakage rates required generate explosive LEL fuel concentrations in the firebox.
- 7.1.6 The light-off of the first pilot/burner shall be manually initiated via pushbutton in the field, with the intent that the field operator will verify safe operation on initial furnace firing.

7.2 SRU Furnace BMS Mandatory Trips

7.2.1 SRU train furnaces shall apply the following mandatory BMS burner, pilot, and master fuel trips.

7.2.2 Air and Acid Gas Preheater Furnaces

7.2.2.1 The following conditions shall cause a trip of the individual burner and pilot BVs:

- a) Loss of both burner and pilot (2oo2) flame detector signals.
- b) Individual burner or pilot BVs out of position.

7.2.2.2 The following conditions shall cause a complete Preheater master fuel trip, extinguishing all fire in the furnace.

- a) Burner header or pilot header BVs out of position.
 - b) Loss of both burner and pilot (2oo2) flame detector
-

signals on a predetermined number of burners.

- c) Burner header fuel gas pressure low-low or high-high.
- d) Pilot header fuel gas pressure low-low or high-high.
- e) Acid gas pass flow low-low (Acid Gas Preheater only).
- f) Air pass flow low-low (Air Preheater only).
- g) Stack damper closed position.
- h) Preheater manual shutdown button.
- i) SRU Train shutdown signal.

7.2.3 Reaction Furnace

The following conditions shall cause a complete Reaction Furnace master fuel trip, which shuts off fuel gas, acid gas and combustion air and extinguishes all fire in the furnace:

- a) Fuel gas burner header BV out of position (when on fuel gas firing).
- b) Loss of both (2oo2) burner flame detector signals.
- c) Fuel gas pressure low-low or high-high (when on fuel gas firing).
- d) Acid gas knock-out drum level high-high (acid gas trip only – fuel gas and combustion air continues).
- e) Reaction Furnace combustion air pressure low-low.
- f) Waste Heat Recovery boiler steam drum level low-low.
- g) Thermal Oxidizer Trip (with 30 minute delay).
- h) Reaction Furnace manual shutdown button.
- i) SRU Train shutdown signal.

7.2.4 Reheat Auxiliary Burners

The following conditions will cause an individual Reheat Auxiliary Burner air and fuel gas trip:

- a) Fuel gas header BV out of position.
 - b) Loss of both (2oo2) auxiliary burner flame detector signals.
 - c) Auxiliary burner fuel gas pressure low-low or high-high.
 - d) Air/Fuel Ratio high-high or low-low.
 - e) Reheat temperature high-high.
-

- f) Reheat Burner manual shutdown button.
- g) SRU Train shutdown signal.

7.2.5 Tail Gas Thermal Oxidizer

7.2.5.1 The following conditions shall cause a trip of the individual burner and pilot BV:

- a) Loss of both burner and pilot (2oo2) flame detector signals.
- b) Individual burner or pilot BVs out of position.

7.2.5.2 The following conditions shall cause a Tail Gas Thermal Oxidizer master fuel trip, extinguishing all fire in the furnace:

- a) Burner header or pilot header fuel BV out of position.
- b) Loss of both burner and pilot (2oo2) flame detector signals on a predetermined number of burners.
- c) Loss of all flame detector signals.
- d) Burner header fuel gas pressure low-low or high-high.
- e) Pilot header fuel gas pressure low-low or high-high.
- f) Thermal Oxidizer outlet temperature high-high.
- g) Thermal Oxidizer manual shutdown button.
- h) SRU Train shutdown signal.

8 Pilot System

8.1 Pilots

8.1.1 Pilot Requirements

8.1.1.1 Pilots shall operate continuously and shall incorporate spark ignitors and flame monitoring.

8.1.1.2 Pilot shall be permanently mounted and located in accordance with burner manufacturer's recommendations. Pilots shall provide sufficient energy to ignite the specified burner combustible fuel-air mixture reliably under all conditions.

8.1.1.3 The pilot flame shall be stable with the burner extinguished and with maximum draft.

8.2 Pilot Flame Monitor and Spark Ignition system

8.2.1 Each pilot shall be provided with a dedicated flame monitor. Rectified ionization type (flame rod) or optical flame scanners shall be used. Flame scanners shall meet requirements specified the Flame Monitoring section below.

8.2.2 Each pilot shall be provided with individual spark ignition.

8.2.3 The power supply to the flame monitoring system shall be from the BMS uninterruptible power source.

8.3 Pilot Gas Header

8.3.1 The pilot gas supply shall be supplied from the burner header, upstream of the first header BV valve. Refer to Figure 1, "Pilot Gas System Diagram."

8.3.2 Each furnace with pilots shall have a separate pilot gas header. Pilot gas to each pilot shall be supplied from the pilot gas header. A quick-closing, manual isolating valve shall be provided in the pilot gas supply, upstream of all controls and at least 50 feet from the furnace. This valve shall be used for emergency isolation or for maintenance purposes.

8.3.3 The pilot gas header shall incorporate automated dual BV block valves with an automated BV bleed valve between. Refer to Figure 1, "Pilot Gas System Diagram."

8.3.4 Filters shall be located upstream of the shutoff and control valves to prevent entry of foreign material into the pilot gas system.

8.3.5 The pilot gas header pressure shall be regulated to the designed operating pressure prior to distribution to the individual pilot subsystem.

8.4 Individual Pilots

8.4.1 Individual pilot gas lines shall be provided with a manual isolating valve, an isolating blind, and a single automated BV valve – in series. Refer to Figure 1, "Pilot Gas System Diagram." It is intended that all pilots will remain lit while the furnace is operational. Any pilots that are removed from service must be isolated via the manual isolation valve and blind.

8.4.2 On furnaces with only a single pilot which is supplied directly from the pilot header – no individual pilot automated BV is required. In this case, the pilot header automated block and bleed valves provide pilot isolation.

8.5 Pilot Combustion Air System

- 8.5.1 The pilot combustion air system shall incorporate the following components, installed in this sequence:
- a) Manual isolating (ball) valve
 - b) Dual-type filter
 - c) Pressure regulating valve
 - d) Pressure gauge
 - e) Two-way direct-acting solenoid valve or air actuated valve. This valve shall be considered a BV valve and be supervised by the BMS.
- 8.5.2 Pilot combustion air shall be clean and dry. Pilots shall not require an external air supply for cooling.

8.6 Pilot Automated Block and Bleed BV Valves

- 8.6.1 Solenoid valves or air actuated quarter-turn ball valves may be used for gas pilot header and individual pilot automated block and bleed BV valves.
- 8.6.2 Pilot solenoid BVs shall be two-way, direct-acting valves suitable for safety shutoff service in gas fired equipment. On loss of electrical power, solenoid block BVs shall fail closed and bleed BVs shall fail open. Solenoid BVs shall be fitted with limit switches detecting the "fully open" and "fully closed" positions for input to the BMS logic system. Solenoids shall have class H, high-temperature insulated coils, and internal trim suitable to the service. Solenoids shall be suitable for continuous duty and shall meet the requirements specified in SAES-J-902.
- 8.6.3 Ball valves used as pilot BVs shall be fire-safe, tight shutoff, quarter-turn ball valves with 316 ss trim. Block BV actuators shall be air open/spring close. Bleed BV actuators shall be air close/spring open. Valves shall be fitted with limit switches detecting the "fully open" and "fully closed" positions for input to the BMS logic system. Actuators shall conform to 34-SAMSS-716, "Pneumatic Actuators, On-Off Service", and valves 2 inches and larger shall conform to Saudi Aramco Specification 04-SAMSS-051.

9 Burner System

9.1 Burner Flame Monitor

Each burner shall be provided with a dedicated UV optical flame monitor.

Flame scanners shall meet requirements specified in the Flame Monitoring section below.

9.2 Burner Fuel Gas Header

9.2.1 Each furnace shall have a separate burner fuel gas header supplied from the plant gas header, configured per Figure 2, "Burner Gas System Diagram." A quick-closing, manual isolating valve shall be provided in the burner header gas supply, upstream of all controls and at least 50 feet from the furnace. This valve shall be used for emergency isolation or for maintenance purposes.

9.2.2 The burner gas header shall incorporate dual automated BV block valves with an automated BV bleed valve between.

9.3 Individual Burners

9.3.1 Individual burner gas supply lines shall be provided with a manual isolating valve, an isolating blind, and a single automated BV – in series. Refer to Figure 2, "Burner Gas System Diagram". It is intended that all burners will remain lit while the furnace is operational. Any burners that are removed from service must be isolated via the manual isolation valve and blind.

9.3.2 On furnaces with only a single burner which is supplied directly from the burner header – no individual burner BV is required. In this case, the burner header automated block and bleed BVs provide burner isolation.

9.4 Burner Combustion Air System

The burner forced draft combustion air system shall incorporate a single automated BV under the supervision of the BMS system.

9.5 Burner Automated Block and Bleed Valves:

9.5.1 The Burner header and individual burner Block and Bleed BVs shall be fire-safe, tight shutoff, quarter-turn ball valves with 316 SS trim. BVs 2 inches and larger shall conform to Saudi Aramco specification 04-SAMSS-051.

9.5.2 Block BV actuators shall be air open/spring close. Bleed BV actuators shall be air close/spring open. Actuators shall conform to 34-SAMSS-716, "Pneumatic Actuators, On-Off Service." Block and bleed valves shall be tagged BV and shall not be provided with manual operators, local pushbuttons, bypass valves, or partial stroke testing features.

9.5.3 Burner and pilot header Block BVs shall close within 10 seconds. Header bleed BVs shall open in less than 2 seconds. Individual burner block BVs with a nominal size of 4 inch and smaller shall close within 2 seconds - BVs larger than 4 inch shall close within 3 seconds. The opening time of individual burner BVs shall be compatible with the burner ignition requirements.

9.5.4 All block and bleed BVs shall be fitted with limit switches detecting the "fully open" and "fully closed" positions for input to the BMS logic system. Limit switches shall conform to requirements in 34-SAMSS-716.

9.6 Acid Gas Automated Block Valves:

At least one automated block BV shall be provided in the acid gas supply line to SRU train. This BV shall be under the control and supervision of the BMS system and shall be fitted with limit switches detecting the "fully open" and "fully closed" positions for input to the BMS logic system. Limit switches shall conform to requirements in 34-SAMSS-716.

10 Flame Monitoring System

10.1 General

10.1.1 Flame monitoring equipment shall be specified in accordance with 34-SAMSS-617.

10.1.2 The furnace flame scanner specification shall identify the type of fuel gas to be fired in the burner and pilot.

10.1.3 The Vendor of the flame monitoring equipment shall submit in writing, for Saudi Aramco Proponent Organization approval, the proposed detection principle for the specified fuel(s).

10.2 Pilot Flame Supervision

10.2.1 The pilot flame detector shall:

- a) Be either a rectified ionization type (flame rod) or optical UV flame detector.
- b) Detect the smallest pilot flame which can provide smooth and reliable ignition of the burner.

10.2.2 The pilot flame detector amplifier shall provide analog output signals to indicate the flame intensity and assist in calibration.

10.3 Number of Detectors

Two flame detectors shall be used per burner - one to detect the pilot flame and other to sight the burner flame. On direct ignited burners that do not use pilots; two flame detectors – both sighting the burner flame - shall be used.

10.4 Flame Monitoring System Design

10.4.1 The flame monitoring equipment shall be fail-safe in accordance with 34-SAMSS-617.

10.4.2 The flame monitoring equipment shall have self-checking features. The cycle time of the self-check function shall be two seconds or less.

10.4.3 The equipment and system design shall permit the operator to distinguish between a flame-out signal and self-check fault.

10.4.4 Two flame detectors shall indicate flame-on during normal operation. Flame-out signals from both the burner and pilot flame detectors shall trip the associated burner and pilot. A flame-out signal from only one of the two flame detectors shall activate an alarm in the control room; the fault shall also be indicated on the local flame safety shutdown (FSS) panel.

10.4.5 An analog indicator of the flame intensity of each detector, or signal connections for this purpose, shall be provided near the flame detector to facilitate detector sighting. A flame status indicating light shall be located on each flame amplifier.

10.4.6 The flame-on and flame-off response times for each particular fuel shall be specified in accordance with 34-SAMSS-617.

10.4.7 The flame detector shall be suitable for continuous operation in an ambient temperature of 100°C when cooling air is not available. With cooling air, the scanner shall be suitable for continuous operation at 65°C.

10.5 Flame Monitoring Air and Nitrogen Purge

For the Reaction Furnace and Auxiliary Combustion Chamber - where air input must be isolated during a furnace trip - flame detectors and peep sights shall be purged with a system that can supply both purge air and nitrogen. The air source shall be the normal purge medium and shall include a BMS supervised block BV to isolate purge air on furnace trip. An additional BMS supervised block BV shall be provided in the nitrogen purge supply to immediately introduce nitrogen in the event of a furnace trip.

11 Control Room and Local BMS Interface

11.1 General

Operational monitoring of the BMS shall be via the Distributed Control System (DCS) in the control room and via a local control panel. The local control panel shall be termed the flame safety shutdown (FSS) panel.

11.2 Local Flame Safety Shutdown (FSS) Panel

11.2.1 Each furnace in the SRU train shall be provided with a dedicated local FSS panel. The FSS panel shall be located near the furnace where the operator may generally observe the furnace burner equipment.

11.2.2 The FSS panel shall provide – as a minimum - the following pushbuttons and indicating lights:

- a) MFT Reset Pushbutton
- b) Purge Start Pushbutton
- c) First Pilot Light-Off Pushbutton
- d) Furnace Online Indicator Lamp
- e) Furnace Shutdown Pullbutton
- f) SRU Train Shutdown Pullbutton
- g) Lamp Test Pushbutton

11.2.3 FSS-mounted BMS indicators and controls shall be discrete push buttons and lights, lamps, or LED's hardwired to the BMS logic system.

11.3 Control Room BMS Operator Interface

11.3.1 General

11.3.1.1 A control room operator interface for the BMS shall be integrated into the Distributed Control System (DCS) using DCS graphic displays.

11.3.1.2 Digital communication between the BMS logic system and DCS shall meet all requirements of SAES-J-601.

11.3.2 BMS – DCS Operator Interface Requirements

The BMS operator interface on the DCS system shall provide all inputs indications and outputs necessary to startup, operate, and shutdown the SRU train. These shall include operator displays for:

- a) Purge permissive status and troubleshooting
- b) Purge status including fuel gas leak test
- c) Pilot and burner light-off and shutdown operation and status
- d) Block or bleed BV position status

11.3.3 Control Room Manual Master Fuel Trip Button

Dedicated manual shutdown buttons for each SRU furnace, as well as for the overall SRU train, shall be provided at the control room operator interface location.

11.3.4 Control Room Alarms

The burner management system shall be configured to communicate each BMS alarm or fault condition to the DCS. The alarm communication shall be designed in accordance with SAES-J-601.

11.3.5 BMS Sequence of Events Functionality

Each SRU furnace BMS shall be provided with sequence of events functionality and a first out log compliant with SAES-J-601.

12 Installation

12.1 General

- 12.1.1 Instruments shall be installed in a vibration-free location as close as possible to the point of measurement. Instrument process piping shall be adequately supported to minimize transmission of vibration to the instruments. Access shall be allowed to facilitate testing, calibration and maintenance.
- 12.1.2 The position of local indicating instruments shall enable them to be observed from grade, platform or walkway while related equipment is operated or when primary instruments are being tested or calibrated.
- 12.1.3 Instruments and components shall be located so that they are protected against direct drainage or blowdown of condensate, water or process fluids from adjacent equipment.
- 12.1.4 All locally mounted instrumentation and associated control equipment shall be accessible from grade, platform, fixed walkway or fixed ladder to facilitate testing and maintenance. Where necessary, provide

standoff shielding around instrumentation to prevent operator contact with high temperature surfaces, as per requirements in SAES-F-001.

12.2 Flame Monitoring Equipment

- 12.2.1 The flame monitoring equipment shall be purchased and installed in accordance with 34-SAMSS-617 and the flame equipment and burner manufacturer's instructions.
- 12.2.2 Vendor approved cable shall be provided for interconnecting scanners to their respective amplifier/relay units. The layout and wiring techniques shall eliminate or minimize the effects of electrical noise on the flame monitoring equipment.
- 12.2.3 The location and installation of the scanner shall permit reasonable access for operations and maintenance personnel.
- 12.2.4 Each scanner shall be installed to permit an unobstructed view of the flame it is supervising under all firing conditions. Scanners should be located or fixed so aim is not disturbed during routine maintenance or burner changes during furnace operation.
- 12.2.5 To assist in optimum sighting, flame scanners shall be installed on a sight-pipe having a swivel-ball mounting.

13 Documentation

Documentation shall be provided as per requirements in SAES-J-601. In addition, the project shall provide:

- a) Calculation documents for each natural draft furnace verifying purge airflow rate.
- b) Calculation documents for each natural draft furnace verifying that the design purge airflow rate and purge time are acceptable to meet the purge requirement of 5 furnace air volume changes.

14 Testing and Inspection

14.1 BMS Testing

BMS inputs and outputs shall be periodically tested as defined in SAES-J-601.

14.2 Block and Bleed BV Testing

The furnace safety system design shall permit the periodic leak testing of all fuel block and bleed BVs.

14.3 Purge Airflow Verification Test

During commissioning, natural draft heaters shall have their purge airflow rate verified against design by field test using portable airflow meters.

14 November 2005 **Revision Summary**
New Saudi Aramco Engineering Standard.

Figure 1 – Pilot Gas System Diagram

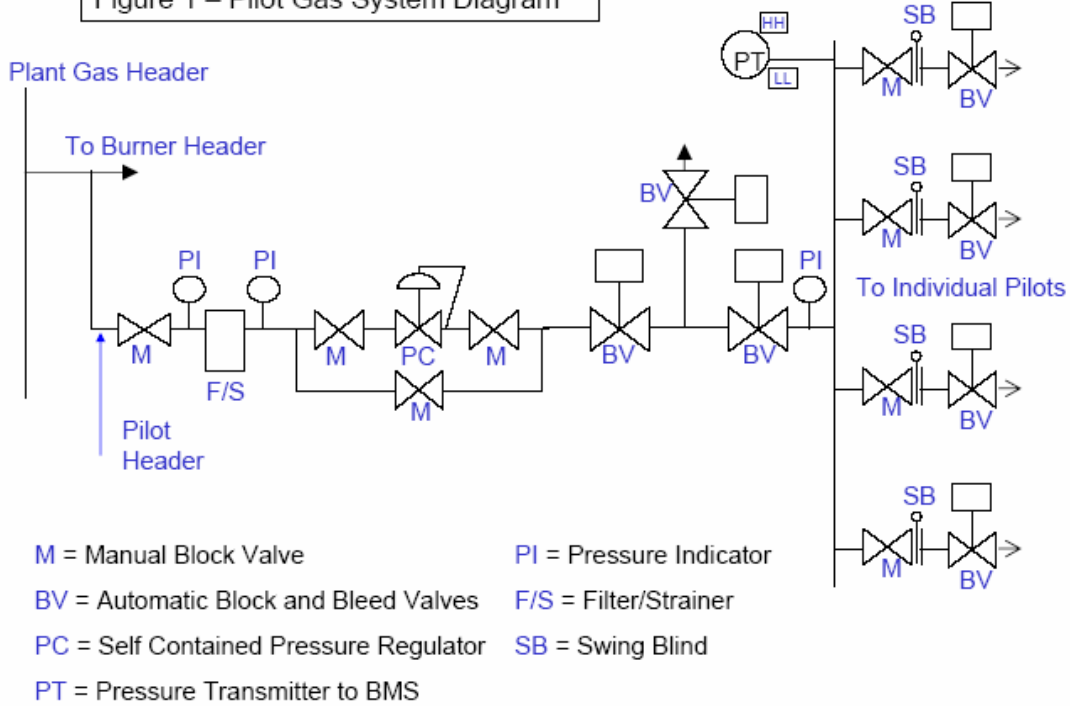

Figure 2 – Burner Gas System Diagram

