

Technical Information

CENTUM CS 3000 Installation Guidance



TI 33Q01J10-01E

Blank Page

Introduction

The CENTUM CS 3000 (abbreviated as CS 3000) is a distributed control system (abbreviated as DCS) for small to large plants.

This manual describes the requirements for installation (control room size and power supply requirements), storage and transportation, and wiring.

I/O modules which can be installed to AFS10S/AFS10D, AFS20S/AFS20D, AFG10S/AFG10D, AFG20S/AFG20D, and PFCS/PFCD are called RIOs; I/O modules installable to AFS30S/AFS30D, AFS40S/AFS40D, AFG30S/AFG30D, AFG40S/AFG40D, and AFF50S/AFF50D are called FIOs.

Chapter 1 System Installation Requirements

This chapter describes engineering specifications covering control room design/environment, power supply system, grounding and noise prevention. For power consumption specifications and list of consumable parts, see Chapter 4.

Chapter 2 Transportation, Storage and Installation

This chapter describes precautions in transit, unpacking and storage, such as humidity, temperature change, and how to install cabinets and 19-inch rack mountable devices.

Chapter 3 Cabling

This chapter describes how to connect power, ground, signal and bus cables to the installed devices, and how to connect optical fiber cables.

Chapter 4 Installation Specifications

This chapter covers power consumption and power dissipation, in-rush current, fuse and breaker ratings, and parts that need replacement within 10 years. Read this section when deciding power supply capacity.

Chapter 5 Post-installation Inspection and Environmental Preservation

This chapter describes items that must be checked before applying power and the precautions to be taken to safeguard the environment after installing the system.

Safety Precautions

Safety, Protection, and Modification of the Product

- In order to protect the system controlled by the product and the product itself and ensure safe operation, observe the safety precautions described in this instruction manual. We assume no liability for safety if users fail to observe these instructions when operating the product.
- If any protection or safety circuit is required for the system controlled by the product or for the product itself, prepare it separately.
- Be sure to use the spare parts approved by Yokogawa Electric Corporation (hereafter simply referred to as YOKOGAWA) when replacing parts or consumables.
- Modification of the product is strictly prohibited.
- The following symbols are used in the product and instruction manual to indicate that there are precautions for safety:



Indicates that a caution must be given for operation. This symbol is placed on the product where the user is recommended to refer to the instruction manual in order to protect the operator and the equipment. In the instruction manuals you will find precautions to avoid physical injury or death to the operator, including electrical shocks.



Identifies a protective grounding terminal. Before using the product, ground the terminal.



Identifies a functional grounding terminal. Before using the product, ground the terminal.



Indicates an AC supply.



Indicates a DC supply.



Indicates that the main switch is ON.



Indicates that the main switch is OFF.

Symbol Marks of Installation Guidance

Throughout this Technical Information, you will find several different types of symbols are used to identify different sections of text. This section describes these icons.



CAUTION

Identifies instructions that must be observed in order to avoid physical injury and electric shock or death to the operator.



IMPORTANT

Identifies important information required to understand operations or functions.

TIP

Identifies additional information.

SEE ALSO

Identifies a source to be referred to.

Cautions for Safely Applying the Device

Wiring Power Cable



CAUTION

Connect the power cables according to the procedure in this document.
Power cables must conform to the safety standards of the country where the device is installed.

**SEE
ALSO**

For Wiring Power Cable, refer to 3.2, "Connecting Power."

Earth Wiring



CAUTION

Ground the device following the procedure in this document to prevent from electric shock and to minimize the noise.

**SEE
ALSO**

For Earth Wiring, refer to 3.3, "Connecting Ground Cable."

Battery



CAUTION

- Must use Yokogawa designated batteries.
 - Mounting and changing batteries must follow the procedure in the hardware instruction manual for each device.
 - When changing batteries while the power supply is not shutdown, do not put hands inside of the device since it is danger of electric shock.
-

Air Filter



CAUTION

Wash the air filters periodically (such as every three months). Use water and the neutral detergent to clean the filter then reuse it after drying.

- Follow the procedure in the hardware instruction manual for each device to exchange the air filter at the specified period.

**SEE
ALSO**

For Air Filter, refer to 4, "Installation Specification (data) Parts Durability."

Fan Unit



CAUTION

When changing fan unit while the power supply is not shutdown, be careful not to touch other parts so as to avoid electric shock.

**SEE
ALSO**

For Fan Unit, refer to 4, "Installation Specification (data) Parts Durability."

Wiring I/O Cables



CAUTION

Wiring I/O cables must follow the procedure in this document.

- CSA 61010-1, CSA 60950-1 (100-120 V AC power) and EN 61010-1 (220-240 V AC power) are recommended as the wiring material and wiring tools for wiring the I/O devices.

**SEE
ALSO**

For Wiring I/O Cables, refer to 3.5, "Connecting Signal Cable."

Power Distribution Board



CAUTION

Exchanging the fuses must follow the procedure in the hardware instruction manual for each device since it has danger of electric shock.

- The fuses for exchange must be the Yokogawa designated fuses.
- Exchanging relay must follow the procedure in the hardware instruction manual for each device so as to avoid electric shock.

**SEE
ALSO**

For Power Distribution Board, refer to 3.4, "Power and Ground Cable."

Exchanging Relay



CAUTION

Exchanging relay must follow the procedure in the hardware instruction manual for each device so as to avoid electric shock.

Exchanging Fuse



CAUTION

- The fuses for exchange must be the Yokogawa designated fuses.
 - Switch off the power supply before exchanging the fuses.
-

Maintenance



CAUTION

- The maintenance work for the devices described in this manual should be performed only by the educated experts.
- When the device becomes dusty, use a vacuum cleaner or a soft cloth to clean it.
- During maintenance, put up wrist strap, and take other ESD (Electrostatic Discharge) measures.
- If the existing caution label is dirty and illegible, prepare a new label (part number: T9029BX) to replace it.

**SEE
ALSO**

For Maintenance, refer to 1.5.2, “Countermeasures against Static Electricity.”

Drawing Conventions

Some drawings may be partially emphasized, simplified, or omitted, for the convenience of description.

Trademark

Trademark

- CENTUM is a registered trademark of YOKOGAWA.
- “FOUNDATION” in “FOUNDATION fieldbus” is a registered trademark of Fieldbus Foundation.
- All other company and product names mentioned in this manual are trademarks or registered trademarks of their respective companies.
- We do not use TM or ® mark to indicate those trademarks or registered trademarks in this manual.

CENTUM CS 3000 Installation Guidance

TI 33Q01J10-01E 13th Edition

CONTENTS

1.	System Installation Requirements	1-1
1.1	Control Room Design	1-2
1.2	Control Room Environment.....	1-5
1.3	Power Supply System	1-14
1.4	Grounding.....	1-19
1.5	Noise Countermeasures	1-26
	1.5.1 Noise Sources and Noise Countermeasures	1-27
	1.5.2 Countermeasures against Static Electricity	1-30
1.6	Cabling Requirements.....	1-31
1.7	Corrosive-gas Environment Compatibility	1-33
2.	Transportation, Storage and Installation	2-1
2.1	Precautions for Transportation	2-2
2.2	Unpacking.....	2-6
2.3	Storage	2-8
2.4	Servicing Area	2-9
2.5	Installation	2-10
	2.5.1 Installation on Floor.....	2-11
	2.5.2 Installing the Console Type HIS Side-by-Side.....	2-15
	2.5.3 Installing Cabinets in a Side-by-Side Arrangement	2-20
	2.5.4 19-inch Rack Mount Devices	2-23
	2.5.5 Desktop Equipment	2-29
	2.5.6 Desk (YAX101, YAX801)	2-30
	2.5.7 Installing Control Bus Interface Card	2-31

3.	Cabling	3-1
3.1	Cables and Terminals	3-2
3.2	Connecting Power	3-5
3.3	Connecting Ground Cable	3-11
3.4	Power and Ground Cabling	3-12
3.5	Connecting Signal Cable	3-30
3.6	Connecting Signal Cables with Fieldnetwork I/O (FIO)	3-49
3.6.1	Combination of Fieldnetwork I/O (FIO) and Terminal Blocks	3-49
3.6.2	List of Signal Cables for Connection with FIO	3-51
3.6.3	Connecting Signal Cables with FIO	3-53
3.6.4	Implementation and Cable Connection of Fieldbus Communication Module ALF111	3-59
3.7	Connecting Signal Cables with Remote I/O (RIO)	3-64
3.7.1	I/O Module Nests	3-64
3.7.2	Signal Cables for Connection with RIO	3-65
3.7.3	Connecting Signal Cables with Analog I/O Modules	3-66
3.7.4	Connecting Signal Cables with Multipoint Control Analog I/O Module AMC80	3-71
3.7.5	Connecting Signal Cables with Relay I/O Modules	3-73
3.7.6	Connecting Signal Cables with Multiplexer Modules (Terminal Type)	3-74
3.7.7	Connecting Signal Cables with Multiplexer Modules (Connector Type)	3-75
3.7.8	Connecting Signal Cables with Digital I/O Modules (Terminal Type)	3-76
3.7.9	Connecting Signal Cables with Digital I/O Modules (Connector Type)	3-77
3.7.10	Connecting Signal Cables with Communication Modules	3-78
3.7.11	Connecting the Fieldbus Cable and Handling the Shield Mesh for Fieldbus Communication Module ACF11	3-85
3.7.12	Connecting Signal Cables with PROFIBUS Communication Module ACP71	3-87
3.8	Connecting Bus Cable	3-88
3.9	Connecting Optical Fiber Cable	3-106
3.10	Alarm and Contact I/O Cabling	3-108
4.	Installation Specifications	4-1
5.	Post-installation Inspection and Environmental Preservation	5-1

1. System Installation Requirements

This section describes installation requirements such as environmental conditions, required space and layout considerations, power consumption, cabling and grounding.

1.1 Control Room Design

The control room, in which the system control equipment is to be installed, should be designed in accordance with the following conditions:

General

In designing a control room, ensure adequate floor strength and air conditioning including dust- and moisture-proofing.

SEE ALSO

- | | |
|--------------------------------|---|
| • 1.1 Control Room Design | Air Conditioner |
| • 1.2 Control Room Environment | Air Purity |
| | Applied Standards (Table JEIDA-63-2000 Classification of Installation Environment Specifications) |

Floor Strength and Space

The floor should have adequate strength, and you should design the layout in accordance with the weight and size of equipment to be installed.

SEE ALSO

- For the maintenance space required, refer to 2.4, "Servicing Area."
- For the weight and dimensions of standard equipment, refer to "External Dimensions" (TI 33Q01J10-02E).

Floor Structure

To prevent damage to cables by operators and maintenance equipment, do not lay cables on the floor.

Lay cables under the floor as follows:

- Provide an "accessible" floor which also facilitates maintenance work.
- Make cable pits under the floor if it is concrete.

Flooding- & Dust-proof Floor

To protect equipment and cables, design a flooding-proof floor.

After the cabling is completed, seal all cable conduits using putty to prevent intrusion of dust, moisture, rats, and insects into the equipment.

Clearance From The Wall and The Floor Surface

There are ventilation holes on the front and rear doors of the cabinets (AFS40S/AFS40D, AFG40S/AFG40D, ACB41, AFS20S/AFS20D, AFG20S/AFG20D, and ACB21). To ensure good air ventilation and easy maintenance, provide a clearance of at least 1000 mm (including the service areas) from the wall to the front and rear doors of the cabinets. Also make sure the height of the ceiling is at least 2400 mm from the floor. For a console HIS (LPCKIT or YPCKIT), a desk (YAX101, YAX801), provide a clearance of at least 1000 mm from the wall to the rear of the unit for heat release and easy maintenance.

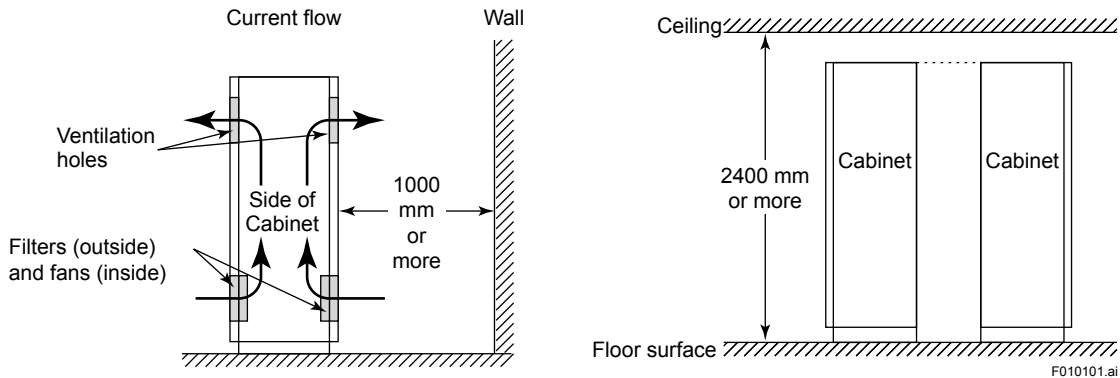

Figure Wall Clearance and Ceiling Height

Illumination

The illumination level around a display unit should be 700 to 1500 lux (target illumination level: 1000 lux). The illumination level inside the control room should be reasonably uniform. Select proper light fixtures and install them in positions where they don't cause glare on the CRT displays and LCDs.

TIP

REFERENCE (Illumination standards):

For ultra-precision work:	1500 to 3000 lux (illumination level: 2000)
For precision work:	700 to 1500 lux (illumination level: 1000)
For ordinary work:	300 to 700 lux (illumination level: 500)
For non-detail work:	150 to 300 lux (illumination level: 200)
Passages, warehouses:	30 to 150 lux (illumination level: 50 to 100)

(Source: JIS Z9110)

Outlets for Maintenance

Outlets (approx. 1.5 kVA) for measurement devices should be provided near the installed equipment for maintenance.

Telephone

Telephones should be installed for communications with related stations.

Air Conditioner

The air conditioner should be operated following the conditions below to prevent dew condensing on the installed equipment:

- Keep the change of temperatures within ± 10 °C/h.
- Install air conditioner away from equipment.
- Install substitute air conditioners to prevent dew condensing as a result of temperature rise or fall if an air conditioner fails.

Windows

Close the windows of the control room. If a draft comes in around the windows, seal around the windows.

Opening the window while air conditioning is running may result in condensation forming, or let in dust or corrosive gas, adversely affecting the installed equipment. Windows on the sea side must be closed to keep out salt air.

Install blinds, if necessary, to prevent sunlight reflecting from CRT displays and LCDs.

Side-by-Side Cabinet Installation

When cabinets are placed side by side, make sure of their ventilation system.

For cabinet ventilation system, we have air-cooling without blower and with blower. Moreover, either blast fan pressurization (door fan) or exhaust fan (ceiling fan) is used for air-cooling with blower.

As cabinets with the same ventilation system can be placed side by side, group them according to ventilation system and place them in the same group side by side with side board.

CENTUM VP, CENTUM CS 3000 and CENTUM CS cabinets get air from the bottom front and rear of the cabinet doors, and emit air from the top front and rear of the doors, using a "fan pressurization" system. On the other hand, CENTUM-XL cabinets get air from rear of the doors, and emit air from the top of the cabinets, using an "exhaust fan" system.

When cabinets with different ventilation systems are placed side by side without using side board, a special partition board must be placed between cabinets. For the board, please contact Yokogawa sales.

1.2 Control Room Environment

This section describes environmental conditions of the control room to operate the system safely, and stably over a long period of time.

It is recommended that user have the control room environment assessment. Consult Yokogawa sales for the assessment if necessary.

Temperatures and Humidity

When equipment is brought from the place out of operational temperature range to the place in operational temperature range, bring it without a package, keep it within temperature change rate and avoid condensation. Keep ambient temperature within operational temperature range and leave it for more than three hours before starting operation.

Under normal operation, the rate of change of ambient temperatures should be within 10 °C/h. All the equipment should be kept out of direct sunlight.

**SEE
ALSO**

See "Table of Equipment Installation Specifications" in this section, for the temperatures and humidity limits for operating and storing this equipment.

Condensation

Prevent condensation. If condensation occurs, or its trace is found on the control room equipment, contact Yokogawa.

**SEE
ALSO**

See "Section 2.3 Storage" for more information.

Vibration

Vibration in the control room should be limited as follows:

- For vibration frequency up to 14 Hz: Limit displacement amplitude to 0.25 mm or less.
- For vibration frequency over 14 Hz: Limit acceleration to 2 m/s² or less.

The following is the relationship of the vibration frequency, displacement amplitude, and acceleration:

$$\text{Acceleration (m/s}^2\text{)} = 4\pi^2 \times A \times F^2 \times 10^{-3}$$

A: Displacement amplitude (mm)
F: Frequency (Hz)

F010201.ai

The allowable range of displacement amplitude is shown below. Consult our engineer if complex vibrations are involved.

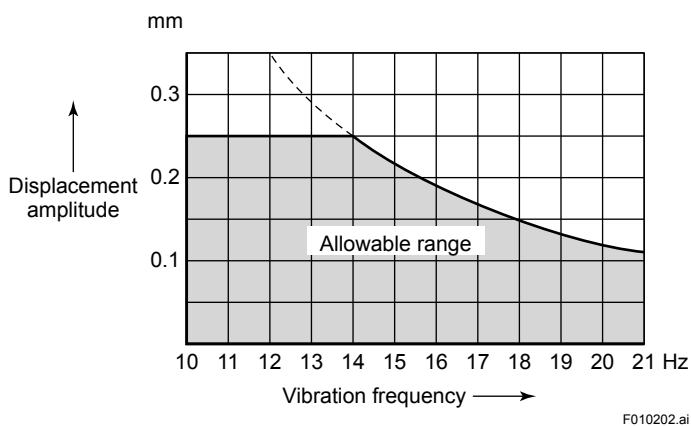

F010202.ai

Figure Range of Allowable Displacement Amplitude

Air Purity

The dust in the control room should be kept below 0.3 mg/m³. Avoid corrosive gas such as hydrogen sulfide (H₂S), sulfur dioxide (SO₂), chlorine, and conductive dust such as iron powder and carbon.

The allowable content of H₂S, SO₂, or any other corrosive gas varies with temperatures, humidity, or existence of other corrosive gas. Consult Yokogawa if corrosive gas exists.

Magnetic Field

Do not install the CRT near cables with heavy current flowing or in the magnetic field of a power supply. If installed in such locations, the display may be distorted or its colors may be affected by the magnetic fields.

Electric field strength (Electric wave condition)

For the proper and stable operation of this system, the electric field strength of the location for the equipment should be controlled as following:

3 V/m or less (26 MHz to 1.0 GHz)

3 V/m or less (1.4 to 2.0 GHz)

1 V/m or less (2.0 to 2.7 GHz)

In case of the usage of wireless equipment such as transceiver nearby this system, note as following:

- The door of this system should be closed.
- In case of the usage of transceiver with 3 W or less, the distance from this system should be kept 1 m or more, with 10 W or less, 2 m or more.
- As for the usage of wireless equipment with 1 W or less such as mobile-telephone, PHS, wireless telephone or LAN equipment, the distance should be kept 1 m or more. Attention should be paid to the micro wave radiated from mobile-telephone or PHS even out of usage.

Following formula represents the electric field strength. However, the calculated value requests ideal environment. Worse conditioned environment should be taken into consideration. In case some wireless equipment is used nearby this system, this formula would be useless. The value calculated through this formula should be considered noting other than reference.

$$E = \frac{k \sqrt{P}}{d}$$

E: Electric field strength (V/m)

k: Coefficient (0.45 to 3.35; average 3.0)

P: Radiation power (W)

d: Distance (m)

F010203.ai

Installation Specification

Installable altitude: up to 2000 m above sea level

IEC 61010-1 installation category: II (*1)

IEC 61010-1 pollution level: 2 (*2)

*1: Also called overvoltage category. Covers impulse withstanding voltage. Class II applies to electrical equipment.

*2: Level of adhesion of solid, liquid, gas, and other foreign substances which reduce insulation resistance. Level 2 applies to ordinary indoor atmosphere.

**SEE
ALSO**

See "Installation Environment Specifications" at the end of this chapter.

Measurement Categories

Regarding to the measurement inputs, to meet the requirements of the device the following specification must be satisfied:

IEC 61010-1 Category: I

The rated transient overvoltage of the measurement category I is 1500 V.

Note: This equipment has Measurement category I, therefore do not use the equipment for measurements within measurement categories II, III and IV.

- Measurement category I
Measurement category I is for measurements performed on circuits not directly connected to MAINS.
- Measurement category II
Measurement category II is for measurements performed on circuits directly connected to the low voltage installation.
- Measurement category III
Measurement category III is for measurements performed in the building installation.
- Measurement category IV
Measurement category IV is for measurements performed at the source of the low-voltage installation.

Applied Standards

The CS 3000 system complies with the standards shown below.



IMPORTANT

Different standards are applied according to the types of equipment. For details, refer to the hardware General Specifications (GS) for each equipment.

Safety Standards (*1)

[CSA]
CSA C22.2 No.61010-1

[CE Marking] Low Voltage Directive
EN 61010-1

*1: To conform to the safety standards and the EMC conformity standards, install the 19-inch rack mountable type devices in a keyed metallic cabinet.

EMC Conformity Standards (*1)

[CE Marking] EMC Directive

EN 55011 Class A Group1 (*2)

EN 61000-6-2 (*3)

EN 61000-3-2 (*4)

EN 61000-3-3 (*5)

[C-Tick Marking]

EN 55011 Class A Group1 (*2)

Standards for Hazardous Location Equipment

[CSA Non-Incendive] (*6)

Class I, Division 2, Groups A, B, C and D Temperature code T4

CSA Standard C22.2 No.157-92

CSA Standard C22.2 No.213-M1987

ISA Standard ISA-S12.12 1994 (for 100-120 V AC and 24 V DC power supply)

[FM Non-Incendive] (*7)

Class I, Division 2, Groups A, B, C and D Temperature code T4

FM Class Number 3600:1998

FM Class Number 3611:2004

FM Class Number 3810:2005

(for 100-120 V AC, 220-240 V AC and 24 V DC power supply)

[Type n] (*8)

EN 60079-15:2005

IEC 60079-0:2004

IEC 60079-11:1999

(for 24 V DC power supply)

[Intrinsic Safety]

EN 50014:1997 +A1 +A2

EN 50020:1994

EN 50021:1999

- *1: To conform to the safety standards and the EMC conformity standards, install the 19-inch rack mountable type devices in a keyed metallic cabinet.
- *2: A Class A hardware device is designed for use in the industrial environment. Please use this device in the industrial environment only.
- *3: A lightning arrester or the like is required to meet this surge immunity standard.
- *4: An external device such as a power unit with harmonic current neutralizer and an active harmonics conditioner must be connected to meet this harmonic current emission standard. See Section 1.3 "Power Supply System".
- *5: The specified limits of voltage drop across wiring must be satisfied to meet this standard. For the selection of the power cables and their wiring, refer to Section 3.2 "Connecting Power".
- *6: To meet a standard for hazardous location equipment, the 19-inch rack-mounted devices must be installed in a keyed metallic cabinet approved by CSA or non-incendive regulator in your area.
- *7: To meet a standard for hazardous location equipment, the 19-inch rack-mounted devices must be installed in a keyed metallic cabinet approved by FM or non-incendive regulator in your area.
- *8: To be compatible with Type n, the specification requirements of EN 61010-1 and EN 60079-15 must be met, and a keyed metallic cabinet, whose degree of protection is IP54 or above, prescribed by IEC 60529 must be used for housing.

Note: According to the New Approach Directive, the manufacturer and the representative office in EU are indicated below.
 Manufacturer : YOKOGAWA Electric Corporation (2-9-32 Nakacho, Musashino-shi, Tokyo 180-8750, Japan).
 Representative office in EU Community : Yokogawa Europe B.V. (Euroweg 2, 3825 HD Amersfoort, The Netherlands).

Installation Environment Specifications

The following table lists environmental requirements for the installation of the CS 3000 system:

For environmental requirements for devices including PC and UPS, refer to their environmental specifications.

**SEE
ALSO**

For details, refer to the hardware general specifications (GS) for each equipment.

Table Equipment Installation Specifications (1/2)

Item		Specifications (LPCKIT)	Specifications (YPCKIT, YAX101 and YAX801)	
Temperature	Normal operation	5 to 40 °C	YPCKIT: 5 to 35 °C YAX101, YAX801: 5 to 40 °C	
	Transportation/storage	-20 to 60 °C	-20 to 60 °C	
Humidity	Normal operation	20 to 80 %RH	20 to 80 %RH	
	Transportation/storage	20 to 80 %RH	20 to 80 %RH	
Temperature fluctuation	Normal operation	Within ±10 °C/h	Within ±10 °C/h	
	Transportation/storage	Within ±20 °C/h	Within ±20 °C/h	
Power source	Voltage range	100-120 V AC ±10 % 220-240 V AC ±10 %	100-120 V AC ±10 % 220-240 V AC ±10 %	
	Frequency	50/60 ±3 Hz	50/60 ±3 Hz	
	Distortion factor	10 % or less	10 % or less	
	Peak value	125 V or larger (for 100-120 V) 275 V or larger (for 220-240 V)	125 V or larger (for 100-120 V) 275 V or larger (for 220-240 V)	
	Momentary failure	20 ms or less	20 ms or less	
Withstanding voltage		1500 V AC/min.	1500 V AC/min.	
Insulation resistance		20 M ohms/500 V DC	-	
Grounding		100 ohms or less	100 ohms or less	
Noise	Electric field	3 V/m or less (26 MHz to 1.0 GHz)	3 V/m or less (26 MHz to 1.0 GHz)	
		3 V/m or less (1.4 to 2.0 GHz)	3 V/m or less (1.4 to 2.0 GHz)	
		1 V/m or less (2.0 to 2.7 GHz)	1 V/m or less (2.0 to 2.7 GHz)	
Magnetic field	30 A/m or less (AC)	30 A/m or less (AC)		
	400 A/m or less (DC)	400 A/m or less (DC)		
Static electricity		4 kV or less (direct discharge) 8 kV or less (aerial discharge)	4 kV or less (direct discharge) 8 kV or less (aerial discharge)	
Vibration	Vibration	Displacement amplitude: 0.25 mm or less (1 to 14 Hz) Acceleration: 2.0 m/s ² or less (14 to 100 Hz)	Displacement amplitude: 0.25 mm or less (1 to 14 Hz) Acceleration: 2.0 m/s ² or less (14 to 100 Hz) excl. LCD	
		Quake resistance	4.9 m/s ² or less	4.9 m/s ² or less excl. LCD
		Vibration during transportation	Horizontal: 2.9 m/s ² or less Vertical: 4.9 m/s ² or less	Horizontal: 2.9 m/s ² or less Vertical: 4.9 m/s ² or less
Impact	Transportation impact	Horizontal: 49 m/s ² or less Vertical: 98 m/s ² or less	Horizontal: 49 m/s ² or less Vertical: 98 m/s ² or less	
Dust		0.3 mg/m ³ or less	0.3 mg/m ³ or less	
Corrosive gas		Class A, JEIDA-63	Class A, JEIDA-63	

Note: The above specifications apply to a KIT only.

Table Equipment Installation Specifications (2/2)

Item		Specifications (except for LPCKIT, YPCKIT, YAX101, YAX801, and ANR10□)	Specifications (ANR10□)	Remarks
Temperature	Normal operation	0 to 50 °C	0 to 60 °C (Temperature option: -20 to 70 °C)(*1)	Avoid direct sunlight.
	Transportation/ storage	-20 to 60 °C	-20 to 60 °C (Temperature option: -40 to 85 °C)	Avoid direct sunlight.
Humidity	Normal operation	10 to 90 %RH (In case of AFF50□ / 5 to 95 %RH)	5 to 95 %RH	No condensation
	Transportation/ storage	10 to 90 %RH (In case of AFF50□ / 5 to 95 %RH)	5 to 95 %RH	No condensation
Temperature fluctuation	Normal operation	Within ±10 °C/h	Within ±10 °C/h	-
	Transportation/ storage	Within ±20 °C/h	Within ±20 °C/h	-
Power source	Voltage range	100-120 V AC ±10 % 220-240 V AC ±10 % 24 V DC ±10 % (including ripple)	100-120 V AC ±10 % 220-240 V AC ±10 % 24 V DC ±10 % (including ripple)	-
	Frequency	50/60 ±3 Hz	50/60 ±3 Hz	-
	Distortion factor	10 % or less	10 % or less	-
	Peak value	125 V or larger (for 100-120 V AC) 274 V or larger (for 220-240 V AC)	125 V or larger (for 100-120 V AC) 274 V or larger (for 220-240 V AC)	-
	Momentary failure	20 ms or less (for 100-120/220-240 V AC)	20 ms or less (for 100-120/220-240 V AC)	With rated voltage supplied
Withstanding voltage		1500 V AC for 1 minute (for 100-120/220-240 V AC)	1500 V AC for 1 minute (for 100-120/220-240 V AC)	Between power & ground terminals
Insulation resistance		20 Mohms at 500 V DC	20 Mohms at 500 V DC	Between power & ground terminals
Grounding		100 ohms or less	100 ohms or less	Independent grounding
Noise	Electric field	3 V/m or less (26 MHz to 1.0 GHz) 3 V/m or less (1.4 to 2.0 GHz) 1 V/m or less (2.0 to 2.7 GHz)	3 V/m or less (26 MHz to 1.0 GHz) 3 V/m or less (1.4 to 2.0 GHz) 1 V/m or less (2.0 to 2.7 GHz)	-
	Magnetic field	30 A/m or less (AC) 400 A/m or less (DC)	30 A/m or less (AC) 400 A/m or less (DC)	Earth magnetism not included in DC magnetic field
	Static electricity	4 kV or less (direct discharge) 8 kV or less (aerial discharge)	4 kV or less (direct discharge) 8 kV or less (aerial discharge)	In accordance with IEC 1000-4-2
Vibration	Vibration	Displacement amplitude: 0.25 mm or less (1 to 14 Hz) Acceleration: 2.0 m/s ² or less (14 to 100 Hz)	Displacement amplitude: 0.25 mm or less (1 to 14 Hz) Acceleration: 2.0 m/s ² or less (14 to 100 Hz)	
	Quake resistance	4.9 m/s ² or less	4.9 m/s ² or less	
	Vibration during transportation	For cabinets: Horizontal: 2.9 m/s ² or less Vertical: 4.9 m/s ² or less For others: Horizontal: 4.9 m/s ² or less Vertical: 9.8 m/s ² or less	Horizontal: 4.9 m/s ² or less Vertical: 9.8 m/s ² or less	In packed condition
Impact	Transportation impact	Horizontal: 49 m/s ² or less Vertical: 98 m/s ² or less	Horizontal: 49 m/s ² or less Vertical: 98 m/s ² or less	In packed condition
Dust		0.3 mg/m ³ or less	0.3 mg/m ³ or less	-
Corrosive gas		Ordinary office level In case of AFF50□/ ISA S71.04.G2 (ISA G3 option: ISA S71.04.G3)	ISA S71.04 G2 (ISA G3 option: ISA S71.04 G3)	-

*1: When an AAP149, AAP849, ADV157, ADV557, ADV161, ADV561, ADV859, ADV159, ADV559, ADV869, ADV169, ADV569, ALR111, ALR121, ALE111, ALF111 and ALP111 is installed, the ambient temperature should range from 0 to 50 °C.

SEE ALSO For the level of corrosive gases permitted in an ordinary office, refer to “Guidelines for Installation Environment” (TI 33Q01J20-01E).

The following table shows the installation environment standard for the occasion where devices including PC or UPS are mounted in the console kit.

Table Installation Environment Standard Used When PC or UPS is Built in Console Kit

Item	Enclosed display style console assembly	Open display style console assembly
Temperature	The range including the console kit temperature range and the installed device temperature ranges (Subtract 5 °C from the upper limit) is the standard for the installation environment.	The range including the console kit temperature range and the installed device temperature ranges is the standard for the installation environment.
Humidity	The range including the console kit humidity range and the installed device humidity ranges is the standard for the installation environment.	
Temperature fluctuation	The console kit temperature fluctuation or the installed device temperature fluctuation whichever is severer is the standard for the installation environment.	
Power source	For the voltage range and frequency, the range including the console kit range and the PC or UPS range is the standard for the installation environment. For the distortion factor, peak value, and instantaneous power failure, the console kit value or the PC or UPS value whichever is severer is the standard for the installation environment.	
Withstand voltage	1500 V AC for 1 minutes for PC or UPS which has obtained IEC 60950-1-equivalent safety standard (EN 60950-1, CSA C22.2 No.60950-1, UL 60950-1). Note: Choose a PC or UPS which has obtained or conforms to the above safety standard.	
Insulation resistance	The console kit insulation resistance or the PC or UPS insulation resistance whichever is lower	
Noise	The console kit value or the PC or UPS value whichever is lower Note: Usually, PCs have obtained EN 55024 or equivalent as noise standard. The EN 55024 standard defines the electrical field, magnetic field, and static electricity as follows: Electrical field 3 V/m 80 to 1000 MHz Magnetic field 1 A/m (AC) No standard for DC Static electricity 4 kV or less (contact discharge), 8 kV or less (aerial discharge)	
Vibration	The vibration characteristic depends on the specifications of the installed devices.	
Dust, corrosive gas	The console kit environmental specification or the PC or UPS environmental specification whichever is severer is the standard for the installation environment.	

JEIDA-63 classifications are shown below:

Table Classification of JEIDA-63 Environment Specifications

		Class A	Class B	Class S (S1)	Class S2	Class S3 (S4)
Temperature and humidity	Temperature	15 to 30 °C	5 to 40 °C	0 to 50 °C	-10 to 60 °C	-25 to 70 °C
	Humidity	40 to 70 %RH	20 to 80 %RH	10 to 90 %RH	5 to 95 %RH	5 to 100 %RH including condensation
	Temperature fluctuation	±5 °C/h	±10 °C/h	±15 °C/h	-	-
Power source	Voltage	±5 %	±10 %	+15 %, -20 %	-	-
	Frequency	±0.5 Hz	±1 Hz	±3 Hz	-	-
	Distortion factor	5 % or less	10 % or less	20 % or less	-	-
	Peak value reduction	2 % or less	5 % or less	10 % or less	-	-
	Instantaneous power failure	3 ms or less	10ms or less or 1/2 cycle or less	200 ms or less	-	-
Grounding		Dedicated class A or C	Dedicated class D	Class D common (excl. power supply equipment)	-	-
Noise	Static electricity (*1)	2 kV	4 kV	6 kV	8 kV	Open
	Electrical field	1 V/m or less	3 V/m or less	10 V/m or less	(Special)	-
	Continuous wave transmission noise	1 V	3 V	10 V	(Special)	-
	Magnetic field	1 A/m or less	3 A/m or less	10 A/m or less	30 A/m or less	100 A/m or less (Special)
	Lightening surge	0.5 kV	1.0 kV	2.0 kV	4.0 kV	Special
	Fast transient/burst wave noise	0.5 kV (Repetitive ratio 5 kHz)	1.0 kV (Repetitive ratio 5 kHz)	2.0 kV (Repetitive ratio 5 kHz)	4.0 kV (Repetitive ratio 2.5 kHz)	Special
Vibration	Continuous vibration	1.0 m/s ² or less	2.0 m/s ² or less	4.9 m/s ² or less	-	-
	Brief vibration (*2)	2.0 m/s ² or less (Seismic intensity 4 or less)	4.9 m/s ² or less (Seismic intensity 5 Upper or less)	9.8 m/s ² or less (Seismic intensity 6 Lower or less)	-	-
	Transportation vibration	Vertical: 4.9 m/s ² or less Horizontal: 2.9 m/s ² or less	Vertical: 9.8 m/s ² or less Horizontal: 4.9 m/s ² or less	Vertical: 19.6 m/s ² or less Horizontal: 9.8 m/s ² or less	-	-
	Transportation impact	Vertical: 49 m/s ² or less Horizontal: 29.4 m/s ² or less	Vertical: 98.1 m/s ² or less Horizontal: 49.0 m/s ² or less	Vertical: 196.1 m/s ² or less Horizontal: 98.1 m/s ² or less	-	-
Dust		0.1 mg/m ³ or less	0.3 mg/m ³ or less	10 mg/m ³ or less	-	-
Corrosive gas		Low temperature and humidity No gas detected. (Evaluation point ≤ 9)	Relatively low humidity Little gas detected. (Evaluation point ≤ 25)	Slightly high humidity Little gas detected. (Evaluation point ≤ 36)	High temperature and humidity Some gases detected. (Evaluation point ≤ 50)	High temperature and humidity A lot of gases detected. (51 ≤ Evaluation point)

JEIDA-63-2000 : Industrial Information Processing and Control Equipment Installation Environment Standard
(Japan Electronics and Information Technology Industries)

*1: Immunity level based on direct contact discharge system

*2: The value enclosed in () indicates the Japan Meteorological Agency Seismic Intensity Scale (reference value) estimated from acceleration.

Class A: No effect on computer system (Difficult conditions for user to meet)

Class B: Office

Class S: Poor environment for computer system, worsening environment class S1→S2→S3

1.3 Power Supply System

For stable operation, a high quality power supply is required. The following conditions should be met:

- Voltage and frequency fluctuations are within the limits specified for each system component.
- Waveform distortion is within limits.
- High-frequency noise is not at a level that affects system operation.
- Use an UPS (uninterruptible power supply) if necessary.

AC Power Specification

AC power used for the system must be within $\pm 10\%$ of specified rated voltage and the peak value must be greater than the minimum specified (see below). DC power must be within $\pm 10\%$ of specified 24 V DC at the power supply terminals.



IMPORTANT

If the power unit has high output impedance or high wiring impedance, the resulting voltage drop flattens the input voltage wave, forming a distorted waveform with a low peak value ("B" in the chart below).

Even if the effective value of the distorted input voltage wave is the same as that specified for a non-distorted input voltage wave, the voltage across the terminals of the smoothing capacitor in the power circuit may be so low that the system detects power failure. If input voltage waves A and B shown below, have the same effective value of 100 V AC, wave B will have a lower smoothing capacitor terminal voltage.

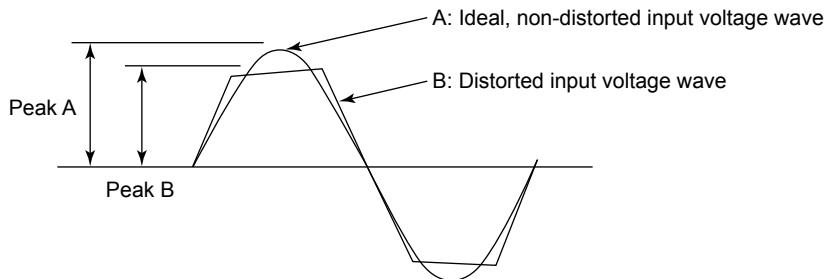

Figure Distorted Input Voltage Waveform

F010301.ai

The system operating voltage range is shown below based on the relationship between effective and peak values at the power input terminal of each system. Apply AC power within these ranges to operate the system.

TIP

Average-value measuring instruments such as digital voltmeters and testers cannot measure effective values accurately. Use Yokogawa's digital oscilloscope DL series or comparable device, which can measure effective values, peak values, and waveform distortion.

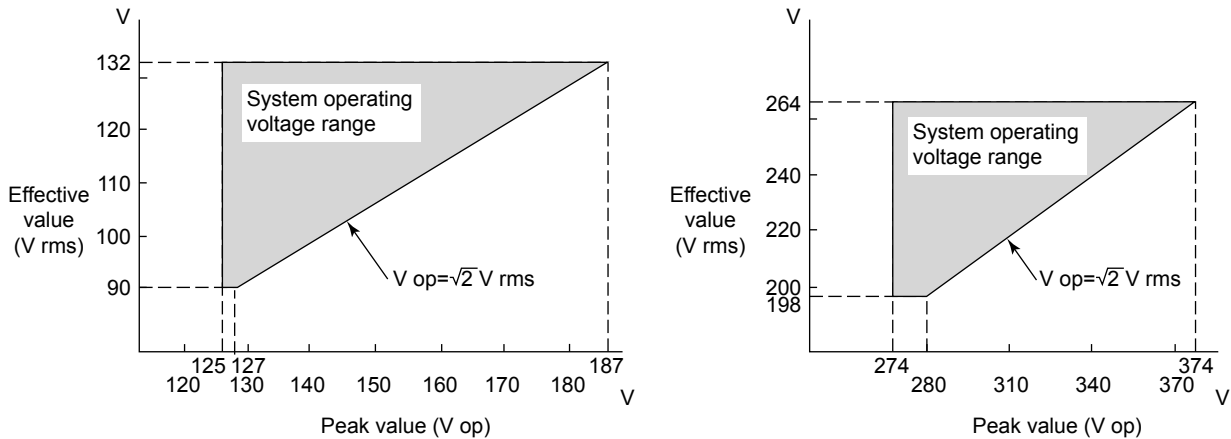

F010302.ai

Figure System Operating Voltage Range

The DC stabilized power supply of the CS 3000 (except General purpose PC) uses a compact and efficient switching regulator circuit. In this circuit, output voltage cannot be maintained if the energy (terminal potential) of the smoothing capacitor falls below a predetermined value. The circuit monitors the capacitor terminal voltage and regards it as power failure if the voltage falls in the danger zone, causing the system to enter power fail mode (non-detected momentary power failure: up to 20 ms).

Current flows to the capacitor in this circuit when AC input voltage is higher than the capacitor terminal voltage. Since the capacitor is charged by the peak value of the input waveform, it is required that both the effective voltage value and the peak value conform to specifications.

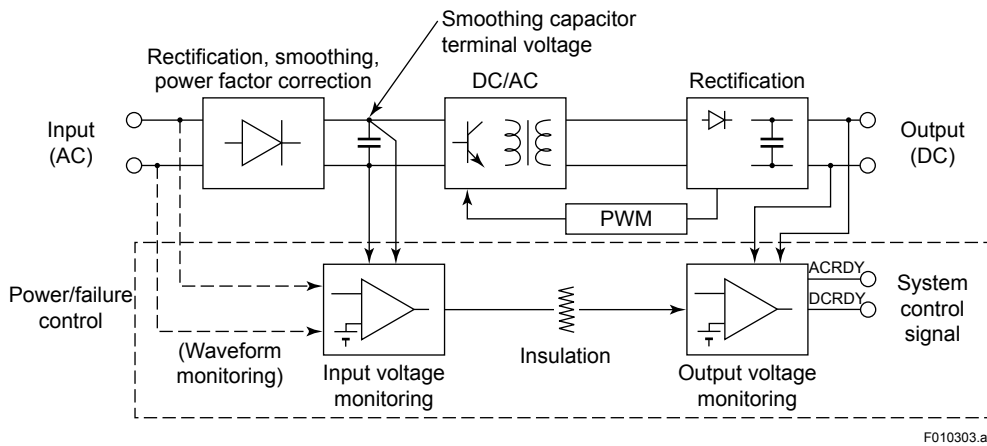

F010303.ai

Figure FCU Power Circuit Diagram

Selecting a Power System

The CS 3000 system requires a power supply that satisfies power requirements in accordance with EMC regulations. It is recommended that an external power supply unit is employed in order to prevent disruptions due to momentary or extended power failure, line noise, or lightning surges, as well as to suppress harmonic current from various devices. For selection of the power supply unit, consult with a power unit manufacturer taking the following points into consideration.

Source Output Capacity

Take the following items into consideration when consulting with a power unit manufacturer to determine the output capacity.

Power consumption:	Both volt-ampere and watt data should be studied (refer to Chapter 4).
Device crest factor:	Ratio of the peak value to the effective value of the device input current.
Device in-rush current:	See Chapter 4 Table "In-rush Current." The method of turning on the power should also be studied.
Backup ready time after failure:	Time period required to backup the devices when power fails.
Reserve capacity:	An extra power capacity should be determined as reserve to meet any device additions.

Crest factor

The crest factor is the ratio of the peak value to the effective value of the device input current.

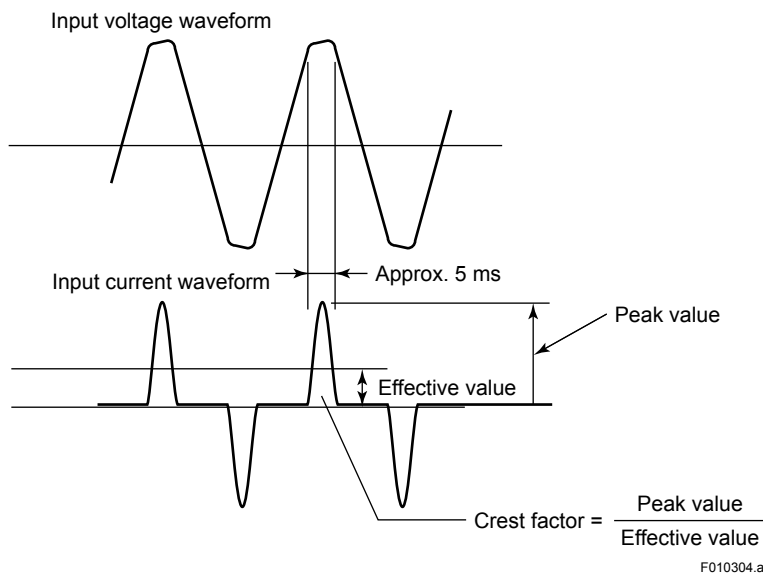

Figure Input Voltage and Input Current Waveforms

Crest factor = Peak value of device input current/Effective value of device input current

The crest factor must be considered for the input current supplied to every device connected to the system when estimating the power output capacity in selecting the power unit. Approximate device crest factors should be as follows:

100-120 V supply voltage: Crest factor About 3.

220-240 V supply voltage: Crest factor About 6.

Common Method to Determine Power Unit Capacity

The following shows the commonly used method used to determine the power unit capacity taking the crest factor into consideration - the final determination should be made in consultation with a power unit manufacturer:

- If the specification of power unit crest factor (the peak current value allowable for the effective current value) is larger than the above device crest factor, the power unit can be used for up to full rated capacity. However, in-rush current, backup time, reserve capacity, etc., must be separately taken into consideration.
- If the power unit crest factor is smaller than the device crest factor, the power unit capacity needs to be calculated in the expression shown below. In-rush current, backup time, reserve capacity, etc., must be separately taken into consideration.

Power unit output capacity = Total device power consumption x Capacity coefficient

Capacity coefficient = Device crest factor / Power unit crest factor specification

In-Rush Current

When the equipment is turned on, a large in-rush current flows as the capacitor is instantaneously charged and the transformer is excited. When any equipment is turned on or shut down, this should not cause any voltage fluctuation that could adversely affect other equipment. Do not turn on all equipment at the same time. Start equipment one by one. Power may be switched to backup or AC line power if in-rush current activates the overload protection circuit on power-up. After such an overload, select an uninterruptible power unit, with automatic-recovery.

Suppressing Harmonic Current

In order to suppress harmonic current supplied to a low-voltage distribution system, it is necessary to install a power unit or an active harmonic suppressor, such as indicated below, between a device and the distribution system:

- Power unit equipped with the harmonic suppression function (a high power-factor inverter-type uninterruptible power unit, etc.)
- Active harmonic suppressor

In Europe, a power unit should be selected so that harmonic current emissions are within the limits specified by EMC regulations.

The capacity of the harmonic suppression unit should be determined in consultation with a power unit manufacturer in the same manner as the selection of power unit's output capacity previously discussed.

Cabling

Observe the following when cabling the power unit to the CS 3000 system equipment:

- Protect signal cables from induced noise.
- Protect signal cables from induction from high-voltage power lines.
- Separate the CS 3000 system power supply from other equipment power supplies-use a separate power distribution board.
- Provide a dedicated breaker for each power supply. Install breakers and devices they control in the same room.
- As far as possible install power supply cables and high-voltage power lines in metallic conduits.
- Use shielded cables if metallic conduits cannot be provided.

1.4 Grounding

To avoid shock hazards and minimize the effects of external noise, the installed devices must be grounded with a ground resistance of 100 ohms or less and a grounding bus of 22 mm² or thicker. Do not ground the CS 3000 system to the same ground as devices of other systems. In the CS 3000 field control station (FCS), expansion I/O cabinets, and console type human interface station (console type HIS), grounding bars are provided. When the power supply is plug-in rather than hard-wired, use the power cable for grounding.

The reference-grounding bar and the concatenation grounding bus, which is for potential equalization defined with the relevant standards, or grounding including meshed earth described in IEC 60364, IEC 62305 and IEC 61000-5-2 can be selected to satisfy the specification of 100 ohms or less.

The term “independent grounding” means to avoid any impedance caused by grounding the system to the same ground as devices of other systems, and it does not necessarily forbid equipotential bonding, nor require to install a grounding electrode independently.

Grounding

Cabinet

- In the AFS40S/AFS40D, AFG40S/AFG40D, ACB41, AFS20S/AFS20D, AFG20S/AFG20D and ACB21, the channel base is isolated from the cabinet by a Bakelite sheet (t=5 mm) to allow one point grounding.
- The grounding bar (1) for connecting a grounding cable is on the bottom of the cabinet near the front panel, which is not isolated from the cabinet.
- The grounding bar (2) for shielding the inside of the cabinet is on the bottom of the cabinet near the back panel, which is isolated from the cabinet. Another grounding bar (3) for shielding the inside of the cabinet is on the bottom of the cabinet near the front panel.
- The grounding bars (2) and (3) are connected to the grounding bar (1) by a cable of 5.5 mm² (This is used for grounding shields of input/output cables).
- When the grounding bars must be grounded separately depending on the purpose (for shielding and for connecting a grounding cable), disconnect the cable between the grounding bar (1) and (3) or (1) and (2), then ground separately.

Enclosed Display Style Console Type HIS (LPCKIT)

The grounding bar for connecting a grounding cable is on the bottom of the console near the front panel, and is isolated from the LPCKIT.

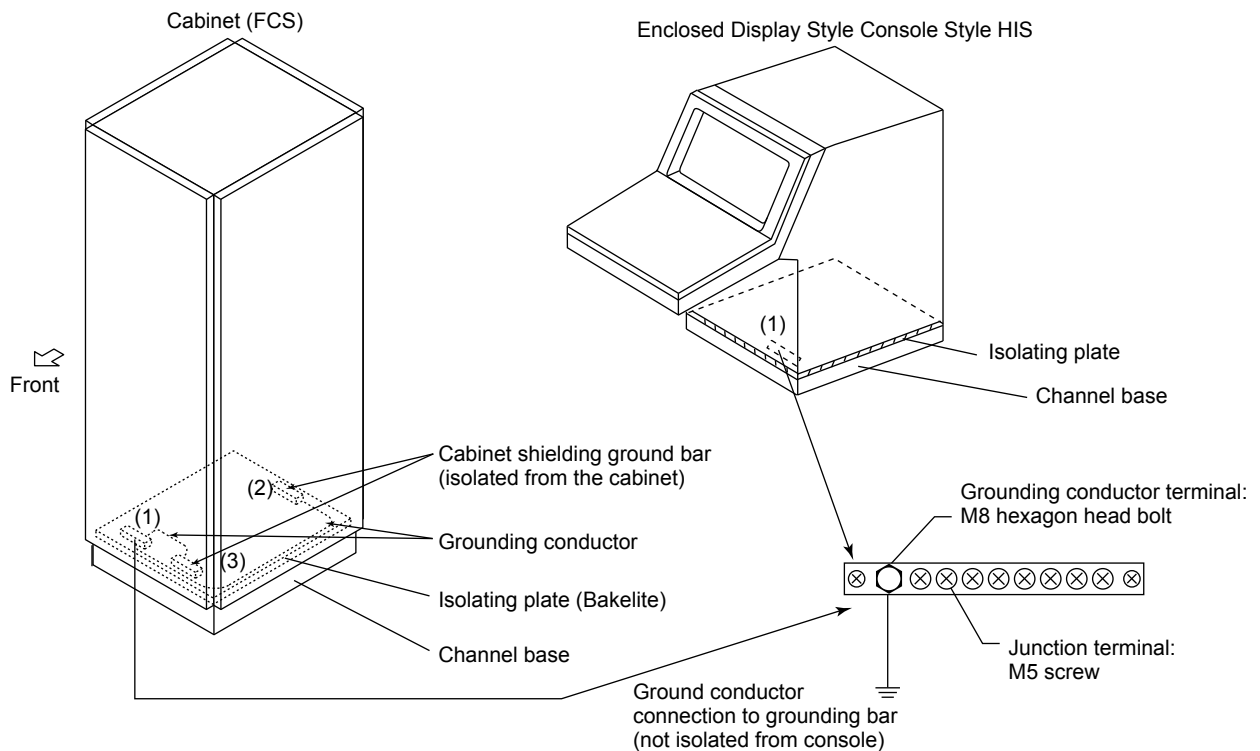
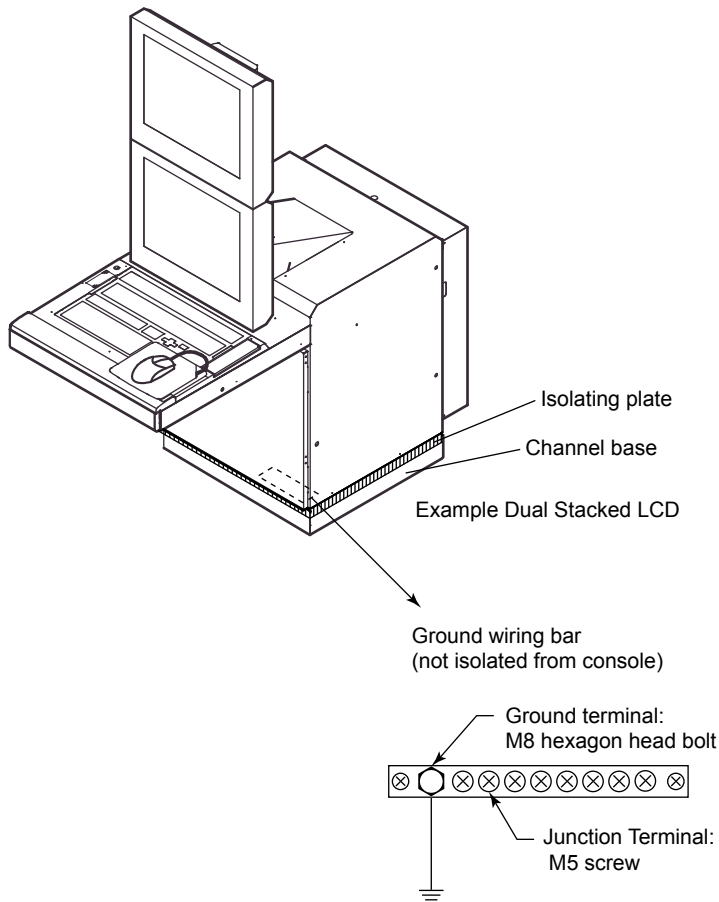

Figure Grounding Bars

F010401.ai

Open Display Style Console Type HIS (YPCKIT)

The grounding bar for connecting a grounding cable is on the bottom of the console near the front panel, and is isolated from the HIS.



F010409.ai

Figure Open Display Style Console Kit Grounding Bar

Grounding Circuit

It is recommended that you ground each cabinet and console type HIS separately. If separate grounding is not feasible, refer to "Grounding Grouped Cabinets" or "Grounding side-by-side Cabinets." When providing lightning arresters on power and signal lines, those arresters need to be grounded to the same bus. For details, see Section 1.5, "Noise Countermeasures."

Separate Grounding

Each cabinet should be grounded as shown below:

Grounding with a ground resistance of 100 ohms or less and a grounding bus of 22 mm² or thicker.

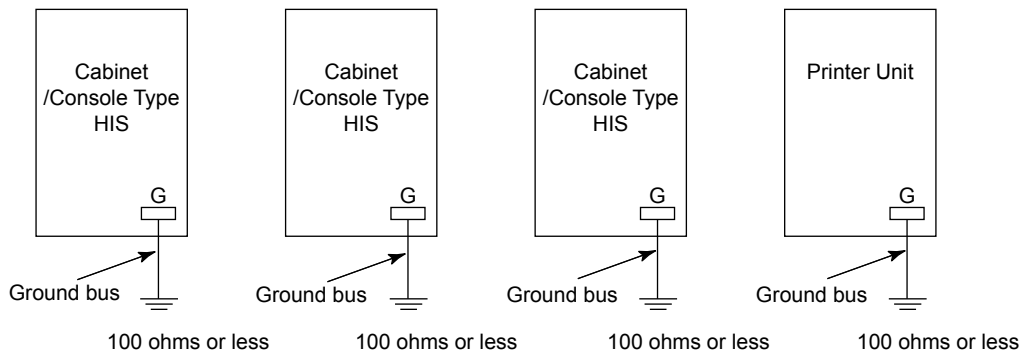

"G" indicates the ground bar.

F010402.ai

Figure Separate Cabinet/Console Type HIS Grounding

Grounding Grouped Cabinets

When Ground Bus Inlet is Provided in Control Room

When installing multiple cabinets/console type HIS in the same room, the ground cables of those cabinets/console type HIS may be connected to one ground bus inlet as illustrated below. A ground cable of at least 5.5 mm² should be used to connect each cabinet and the inlet.

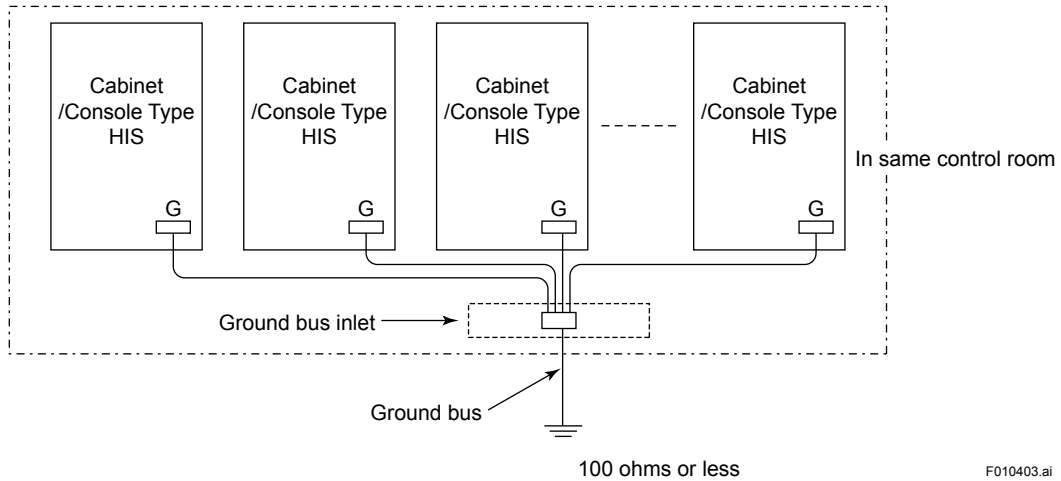

Figure Grounding Through Ground Bus Inlet

Providing Ground Bus in Cabinet/Console Type HIS

When installing multiple cabinets in the same room but no ground bus inlet is provided in the room, the ground bus may be connected directly to the ground bars inside the individual cabinets as illustrated below. A ground cable of at least 5.5 mm² should be used to connect the cabinet/console type HIS with the ground bus to others.

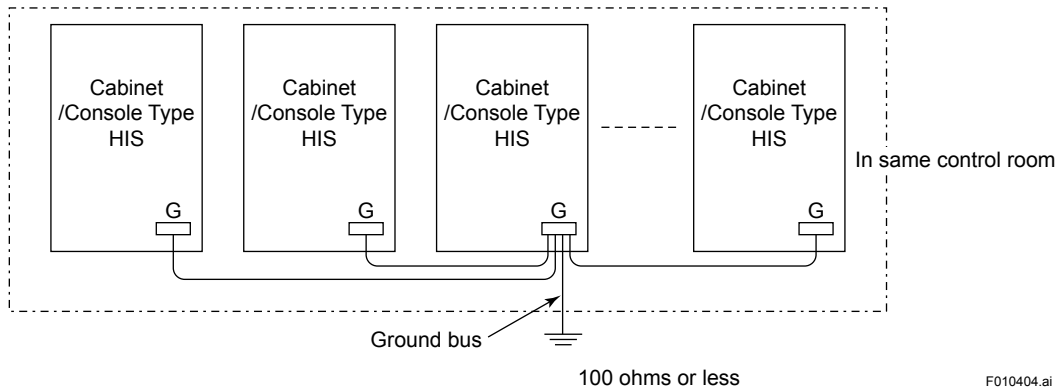

Figure Grounding Via Cabinet/Console Type HIS with Ground Bus

Grounding with Other System

As far as possible, avoid mounting CS 3000 in contact with an other system. If this cannot be avoided, either provide insulating sheets and separate grounding or insulate the other system from the floor, and ground both CS 3000 and the other system via a common ground bar.



IMPORTANT

Do not install the following systems side-by-side with CS 3000:

- Systems using power supply voltages over 300 V AC.
- Systems with current consumption over 50 A.
- System containing high frequency sources.

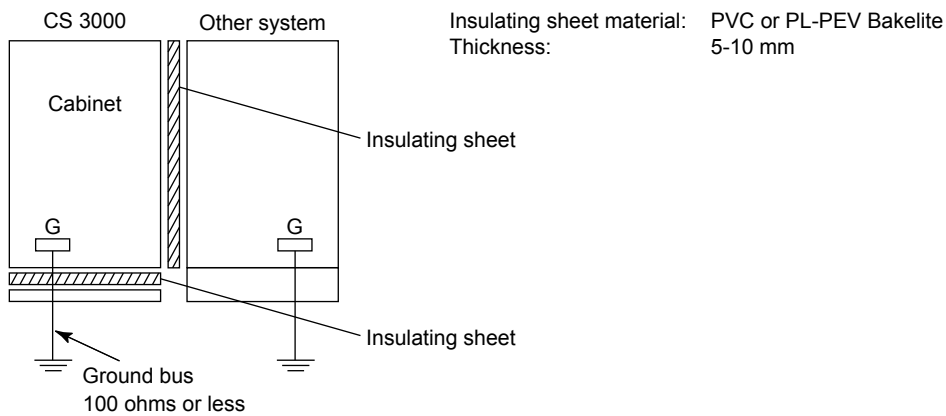

F010405.ai

Figure Grounding Using Insulating Sheets

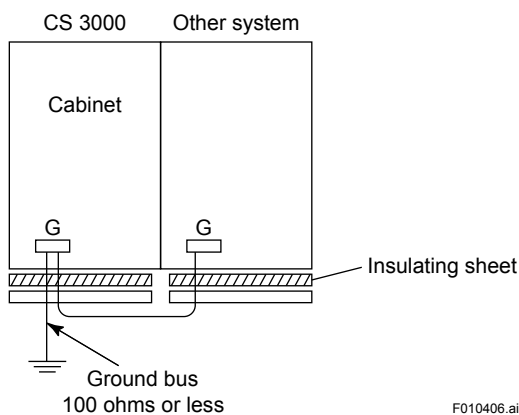

F010406.ai

Figure Grounding by Insulation from Floor

Grounding Side-by-side Cabinets

When cabinets/console type HIS are installed side-by-side, their grounding is electrically combined. Use ground cables of at least 5.5 mm² for intercabinet connections.

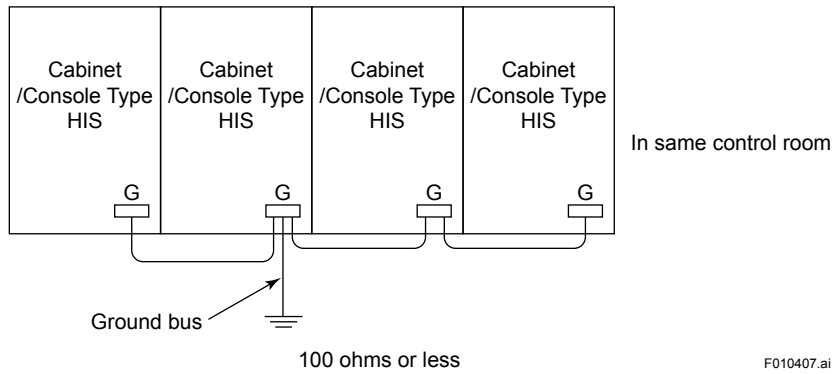

Figure Grounding Side-by-side Cabinets

F010407.ai

1.5 Noise Countermeasures

Noise may be induced by electromagnetic induction, electrostatic induction, or from radio waves, lightning, inductive loads, static electricity and ground potential differences. It can be picked up by power, signal and ground cables, and devices. With computerized control systems, noise-induced errors in A/D conversion or in an instruction word may lead to malfunction.

To prevent noise and electrostatic buildup, take the measures described in this section in deciding cable type, cable routing, and grounding.

1.5.1 Noise Sources and Noise Countermeasures

It is not easy to identify the cause of any noise-triggered errors or failures due to their lack of reproducibility.

If noise problems occur, take the following countermeasures.

The following table lists typical noise sources, symptoms of noise problems, and preventive countermeasures:

Table Noise Sources & Countermeasures

Noise sources	Effects	Countermeasures
Electromagnetic induction (magnetic field)	<ul style="list-style-type: none"> • CRT display instability, distortion, color shift, color fringing. • Destroys magnetic/flexible disk data. 	<ul style="list-style-type: none"> • Maintain separation from magnetic-field source. • Shield power cables with metallic conduits. • Shield magnetic field using ferromagnetic substance (e.g. Permalloy). Or use LCD. • Use twisted-pair cables.
Electrostatic induction	<ul style="list-style-type: none"> • Equipment maloperation. • Interference with signals. 	<ul style="list-style-type: none"> • Use shielded signal cables. • Electrically separate power and signal cables using metallic conduits and separators. • Lay power and signal cables which intersect at right angles.
Lightning	<ul style="list-style-type: none"> • Interference with signals. • Equipment maloperation. • Component damage. 	<ul style="list-style-type: none"> • Lay cables underground. • Use optical fiber cables. • Lay cables as close to ground as possible if the cables cannot be laid underground. • Install and ground arresters on field and system.
Electrostatic discharge	<ul style="list-style-type: none"> • Equipment maloperation. • Electronic component deterioration, damage. • Paper jam. 	<ul style="list-style-type: none"> • Discharge static electricity from operators. • Provide proper humidity. • Ground equipment properly. • Use antistatic floor material and clothing.
Inductive load open/close	<ul style="list-style-type: none"> • Spike noise interference to power and signal lines. 	<ul style="list-style-type: none"> • Add spark-killer to noise source. • Separate laying of cables.
Radio (electric field)	<ul style="list-style-type: none"> • CRT display disruption. • Equipment maloperation. • Interference with signals. 	<ul style="list-style-type: none"> • Keep at least 1 m away from devices to use a transceiver or a PHS or a cellular phone (max. output is 1 W).
Ground potential difference	<ul style="list-style-type: none"> • Equipment Maloperation (noise imposed on signal lines) 	<ul style="list-style-type: none"> • Avoid multipoint grounding of signal cable.

Grounding with Lightning Arresters

Connect the grounding terminals of arresters and CS 3000 equipment to the grounding pole as shown in the diagram below. Leading the ground cable from an arrester to equipment or grounding them to separate buses may result in loss of protection capability. Be sure to connect the ground cable from equipment to an arrester and connect the arrester to a ground bus. Use type 10 ohms or less or type 100 ohms or less.

Concatenation grounding a lightning arrester and other equipment may cause high-tension in each equipment by the product of lightning current from arrester and grounding resistance. To prevent from electrification, overall connection should be equipotential including the floor and the case of other equipment.

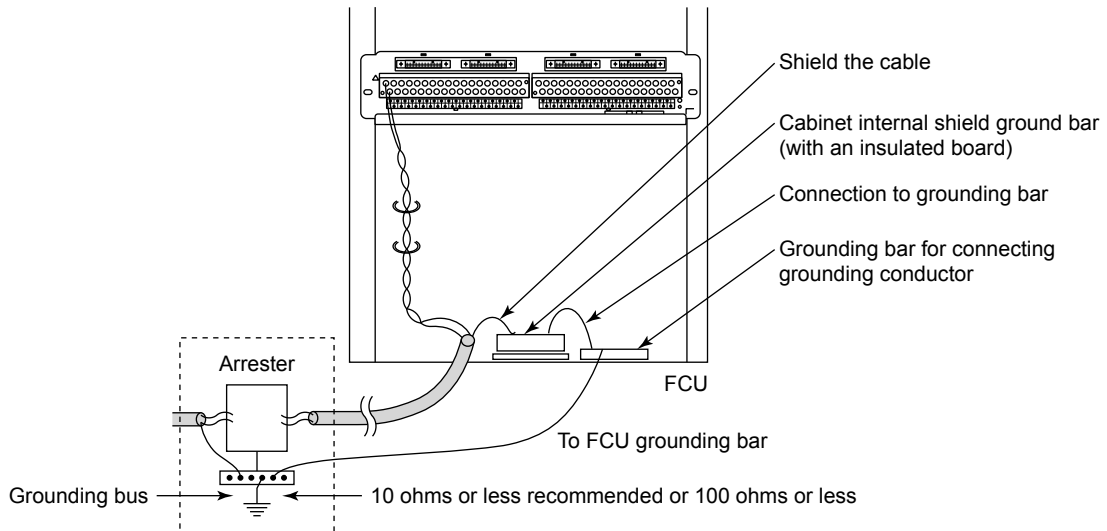

F010504.ai

Figure Grounding with Lightning Arresters

Examples of Arrester

The following shows how to install an arrester as a countermeasure against lightning-induced noise :

▼ : Induced lightning strike point AR: Arrester

● 2-wire transmitter/analyzer

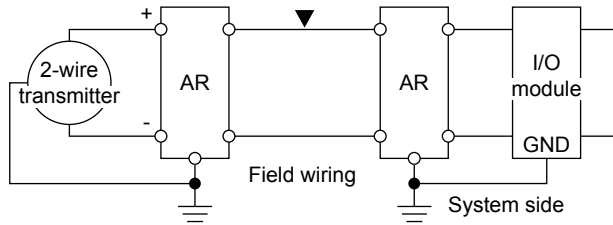

● Thermocouple

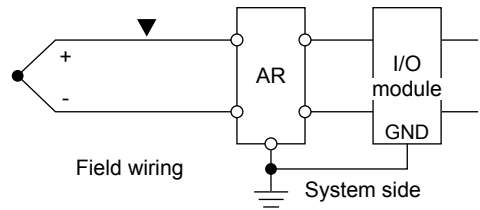

● Resistance temperature detector

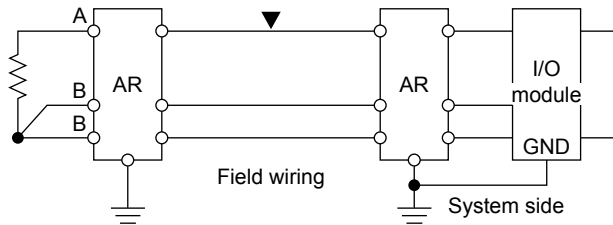

● Power supply

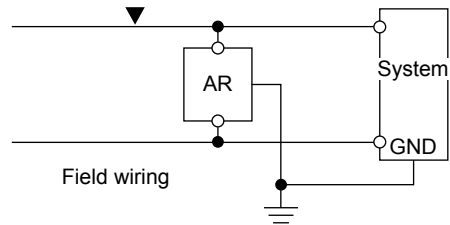

F010501.ai

Figure Examples of Arrester Installation

Examples of Spark-killer Installation

The following shows how to install a spark-killer as a countermeasure against inductive load-caused noise:

● Relay contact

The diode protects the output transistor from noise occurring during on-to-off transitions of the relay.

The spark killer protects the output relay contact.

Example
R: 120 ohms
C: 0.1 to 0.3 μ F

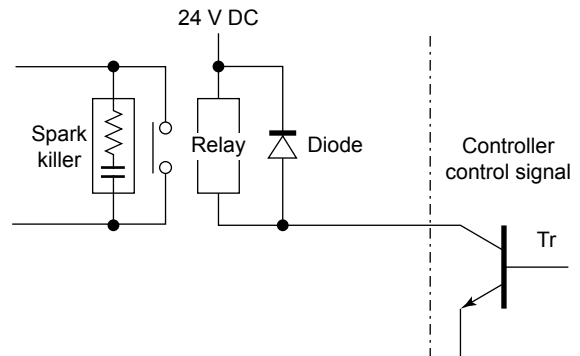

● Power supply

The spark killer prevents noise-caused equipment failure when a fluorescent lamp or fan is turned on or off.

Example
R: 120 ohms
C: 0.1 μ F

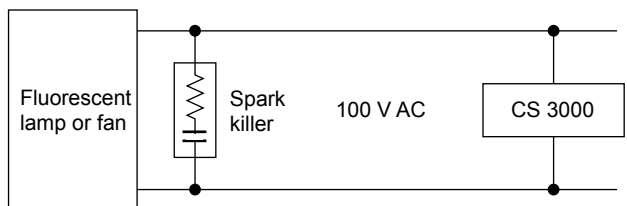

F010502.ai

Figure Examples of Spark-killer Installation

1.5.2 Countermeasures against Static Electricity

Take countermeasures against electrostatic damage when handling cards with semi-conductor IC components, for maintenance or to change settings.

Observe the following to prevent electrostatic damage:

- When storing or carrying maintenance parts, keep them in a conductive bag (when delivered from the factory, they are packed in such bags with labels warning about static electricity).
- When doing maintenance work, wear a wrist strap connected to a ground wire with a grounding resistance of 1 M ohm. Be sure to ground the wrist strap.

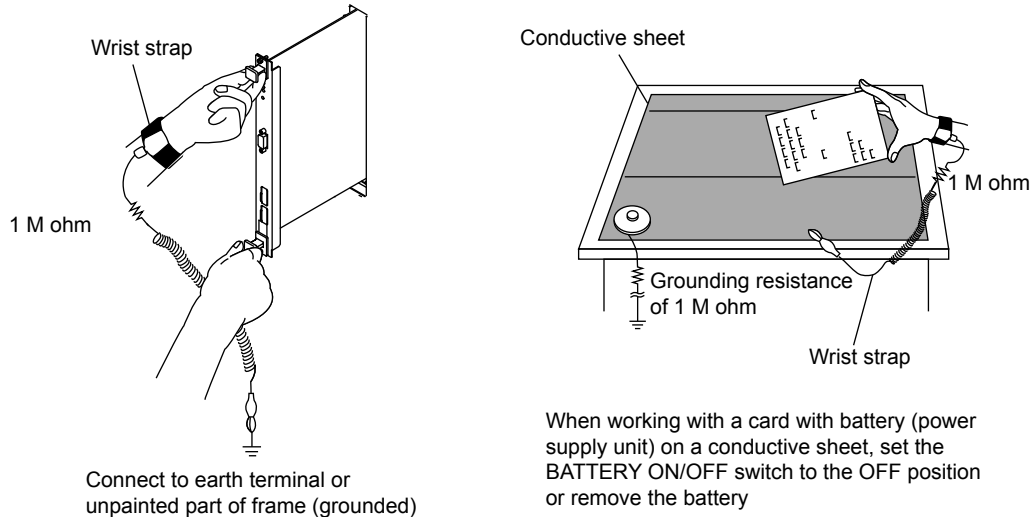

F010503.ai

Figure Example of Use of A Wrist Strap and Conductive Sheet

- When working on cards: keep conductive sheets, grounded via a resistance of 1 M ohm, on the work bench. Wear a grounded wrist strap. Remove electrostatic plastics from the work bench.
- Be sure to wear a wrist strap and use a conductive sheet when handling maintenance parts.
- Wrist straps and conductive sheets are available from Yokogawa.

1.6 Cabling Requirements

The following requirements must be fulfilled when laying power and signal cables (These are shielded cables unless specified).

Any signal cable used for high-voltage, high-frequency signals (inductive load ON/ OFF) must be separated from other signal cables.

Separator

Provide a separator between power and signal cables as illustrated below:

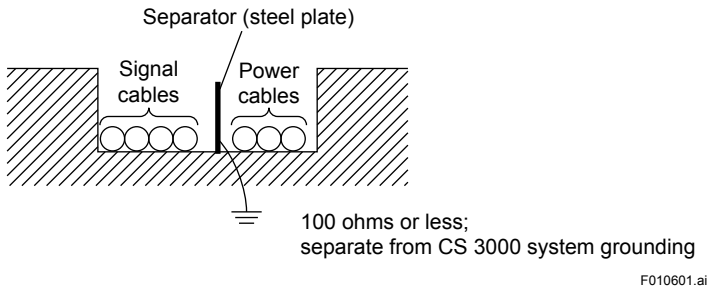

Figure Separator Used in Duct/Pit

Distance between Cables

If a separator cannot be used, keep a distance between signal cables and power cables. The distances between cables due to operating voltages and currents are shown below.

Table Required Distance between Power & Shielded Signal Cables

Operating voltage	Operating current	Distance
240 V AC max.	10 A max.	150 mm min.
240 V AC max.	10 A min.	600 mm min.
240 V AC min.	10 A max.	600 mm min.
240 V AC min.	10 A min.	Cannot be laid together.

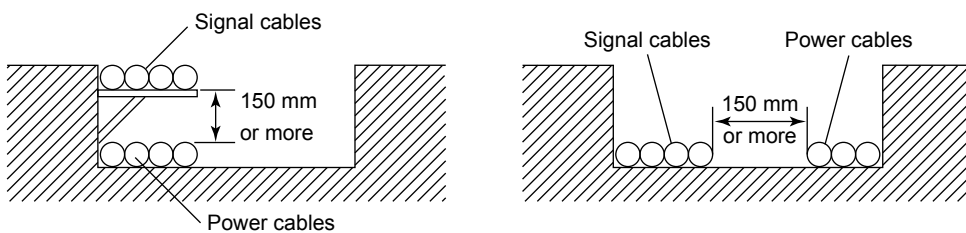
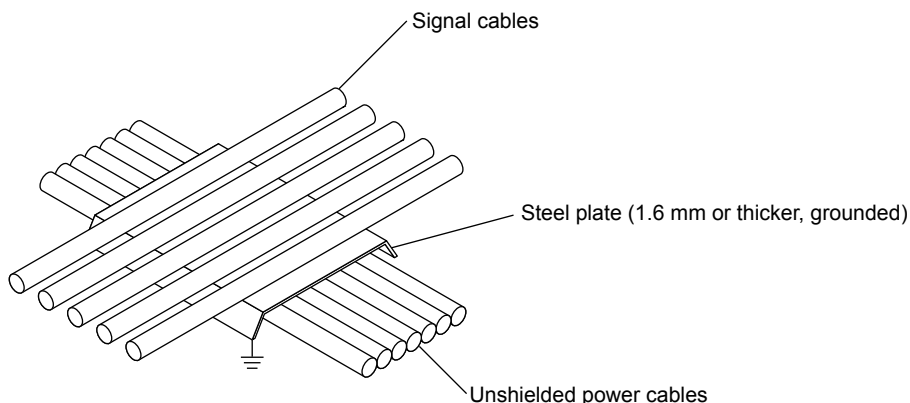

Figure Distance between Cables under Pit/Free-access Floor

Intersecting Cables

With unshielded power cables, place a grounded steel plate with a thickness of at least 1.6 mm over the cables where they intersect with signal cables.



F010603.ai

Figure Intersecting Cables under Pit/Free-access Floor

Ambient Temperature

The ambient temperature where signal and bus cables are laid must be within the range -10 to 60 °C.

When using ER bus node units (ANR10S/ANR10D) to conform to the temperature specification, the ambient temperature where the cables are laid must be within the range -20 to 70 °C.

Measures against EMI

As a rule, avoid laying the cables on the floor. However, lay them on the floor when there are no ducts and no pits. In that case, it is required to cover them with shield plates or take other measures to suit the EMC Directive.

1.7 Corrosive-gas Environment Compatibility

The CS 3000 system employs ER bus node units and FIO input/output modules which meet the ANSI/ISA G3 environment requirements and are compatible with the corrosive gas-susceptible environment.

G3 Environment-compatible Products

Table G3 Environment-compatible Products (1/2)

No.	Product	Model	Description
1	Field control unit	AFF50□-□□□□1	Compact Field control unit (for FIO)
2	Node unit	ANR10□-□□3	ER bus node unit (19-inch Rack Mount type)
3	Analog I/O modules	AAI141-□□3	Analog input module (4 to 20 mA, 16-channel, non-isolated)
		AAV141-□□3	Analog input module (1 to 5 V, 16-channel, non-isolated)
		AAV142-□□3	Analog input module (-10 to +10 V, 16-channel, non-isolated)
		AAI841-□□3	Analog I/O module (4 to 20 mA input, 4 to 20 mA output, 8-channel/8-channel, non-isolated)
		AAB841-□□3	Analog I/O module (1 to 5 V input, 4 to 20 mA output, 8-channel/8-channel, non-isolated)
		AAV542-□□3	Analog output module (-10 to +10 V, 16-channel, non-isolated)
		AAP149-□□1	Pulse input module for compatible PM1 (16-channel, pulse count, 0 to 6 kHz, non-isolated)
		AAP849-□□1	Pulse input/Analog output module for compatible PAC (Pulse count input, 4 to 20mA output, 8-channel/8-channel, non-isolated)
		AAI143-□□3	Analog Input Module (4 to 20 mA, 16-Channel, Isolated)
		AAI543-□□3	Analog Output Module (4 to 20 mA, 16-Channel, Isolated)
		AAV141-□□3	Analog input module (-10 to +10 V, 16-channel, isolated)
		AAV544-□□3	Analog output module (-10 to +10 V, 16-channel, isolated)
		AAT141-□□3	Thermocouple/mV input module (16-channel, isolated)
		AAR181-□□3	Resistance temperature detector input module (12-channel, isolated)
		AAI135-□□3	Analog input module (4 to 20 mA, 8-channel, isolated channels)
		AAI835-□□3	Analog I/O module (4 to 20 mA, 4-channel/4-channel, isolated channels)
		AAT145-□□3	Thermocouple/mV input module (16-channel, isolated channels)
		AAR145-□□3	Resistance temperature detector/potentiometer input module (16-channel, isolated channels)
AAP135-□□3	Pulse input module (8-channel, 0 to 10 kHz, isolated channels)		

Table G3 Environment-compatible Products (2/2)

No.	Product	Model	Description
4	Digital I/O modules	ADV151-□□3	Digital input module (32-channel, 24 V DC, isolated)
		ADV141-□□3	Digital input module (16-channel, 100 to 120 V AC, isolated)
		ADV142-□□3	Digital input module (16-channel, 220 to 240 V AC, isolated)
		ADV551-□□3	Digital output module (32-channel, 24 V DC, isolated)
		ADR541-□□3	Relay output module (16-channel, 24 to 110 V DC/100 to 240 V AC, isolated)
		ADV157-□□1	Digital input module (32-channel, 24 V DC, for pressure clamp terminals, isolated)
		ADV557-□□1	Digital output module (32-channel, 24 V DC, for pressure clamp terminals, isolated)
		ADV161-□□1	Digital input module (64-channel, 24 V DC, isolated)
		ADV561-□□1	Digital output module (64-channel, isolated)
		ADV859-□□1	Digital I/O module for compatible ST2 (16-channel input/16-channel output, isolated channels)
		ADV159-□□1	Digital input module for compatible ST3 (32-channel, isolated channels)
		ADV559-□□1	Digital output module for compatible ST4 (32-channel, isolated channels)
		ADV869-□□1	Digital I/O module for compatible ST5 (32-channel input/32-channel output, isolated, common minus side every 16-channel)
		ADV169-□□1	Digital input module for compatible ST6 (64-channel, isolated, common minus side every 16-channel)
ADV569-□□1	Digital output module for compatible ST7 (64-channel, isolated, common minus side every 16-channel)		
5	Communication module	ALR111-□□1	RS-232C Communication Module (2-Port, 1200 bps to 115.2 kbps)
		ALR121-□□1	RS-422/RS-485 Communication Module (2-Port, 1200 bps to 115.2 kbps)
		ALE111-□□1	Ethernet Communication Module (1-Port, 10 Mbps)
		ALF111-□□1	Foundation Fieldbus (FF-H1) Communication Module (4-Port, 31.25 kbps)
		ALP111-□□1	PROFIBUS-DP Communication Module (1-Port, 9600 bps to 12 Mbps)

Outline of G3 Environment Compatibility

The classification of the environment in which the process control equipment is installed is determined by the ANSI/ISA S71.04 "Environmental Conditions for Process Control Systems" standard. The environment having an atmosphere which contains steams and mists (liquids, coded L), dusts (solids, coded S), or corrosive gases (gases, coded G) is classified into four categories according to the levels of these substances determined.

The four categories of the corrosive gas environment are defined as follows:

- G1 (Mild):** A well-controlled environment in which corrosive gas is not the major cause adversely affecting the reliability of plant equipment. The corrosion level on the copper test piece is below 0.03 μm (see note below).
- G2 (Moderate):** An environment in which corrosive gas can be detected and it could be determined that the gas is the major cause adversely affecting the reliability of plant equipment. The corrosion level on the copper test piece is below 0.1 μm (see note below).
- G3 (Harsh):** An environment in which corrosive gas is frequently generated to cause corrosion and that it is necessary to provide special measures or employ specially designed or packaged plant equipment. The corrosion level on the copper test piece is below 0.2 μm (see note below).
- GX (Severe):** A corrosive gas-polluted environment that demands special protective chassis for the plant equipment, specifications of which should be seriously determined by the user and a power unit manufacturer. The corrosion level on the copper test piece is 0.2 μm or more (see note below).

Note: Copper test pieces are used to determine the level of corrosion for the classification of the plant environment. The test piece is an oxygen-free copper sheet, which is 15 cm² in area, 0.635 mm in thickness, 1/2 to 3/4 H in hardness. The test piece is placed in the plant site for one month and checked for any change before and after the test to determine the degree of corrosion (see table below). If the test period is shorter than one month, the result is calculated to obtain equivalent data using an expression defined by the standard.

Table Classification of Corrosive-gas Corrosion Levels

Environment category		G1 (Mild)	G2 (Moderate)	G3 (Harsh)	GX (Severe)	
Copper corrosion level		< 300 (< 0.03)	< 1000 (< 0.1)	< 2000 (< 0.2)	\geq 2000 (\geq 0.2)	[A] (μm)
Group A	H ₂ S	< 3	< 10	< 50	\geq 50	[mm ³ /m ³]
	SO ₂ , SO ₃	< 10	< 100	< 300	\geq 300	
	Cl ₂	< 1	< 2	< 10	\geq 10	
	NO _x	< 50	< 125	< 1250	\geq 1250	
Group B	HF	< 1	< 2	< 10	\geq 10	
	NH ₃	< 500	< 10000	< 25000	\geq 25000	
	O ₃	< 2	< 25	< 100	\geq 100	

Note: The gas density data indicated in the table are for reference only, with the relative humidity of 50 %RH or less. The category goes up one rank higher every time the humidity increases 10 % exceeding the 50 %RH or over 6 % per hour.

The Group-A gases shown in the table may coexist and cause inter-reaction. Inter-reaction factors are not known for the Group-B gases.

2. Transportation, Storage and Installation

This chapter describes the precautions in transporting, storing, and installing the CS 3000 system equipment.

SEE ALSO See "Section 1.2 Control Room Environment" for the environmental requirement for each piece of equipment.

2.1 Precautions for Transportation

This section describes the precautions required to prevent accidents and damage when transporting CS 3000 system equipment. These precautions apply when the equipment is contained in our original packing.

Transportation

**SEE
ALSO**

See "Table Equipment Installation Specifications" in Section 1.2 Control Room Environment for ambient temperature, humidity, vibration and impact.

Loading

- Do not load crates on top of others or turn them on their sides.
- Keep all crates upright.
- Secure loaded crates using ropes, and cover them completely with waterproof coverings.
- Do not load crates outdoors when it is raining.

Don't Stack Outdoors

Be sure to store cargoes inside a warehouse if they must be stored for some time.

Transportation

Cargoes contain precision instruments. Select a company specializing in the transportation of computers and precision instruments.

Keep all products upright during air transport, freightage, or truck transport. When transporting by track, drive at low speed to avoid vibration and impact. Also, slow down to the limit on a bad road.

Transportation for LPCKIT, YPCKIT

When transporting these kits, pack its personal computer (main body) and UPS (if installed) separately from others. For YPCKIT, LCD must be packed separately as well.

Others

Do not transport equipment through areas where there may be corrosive gas, intense electric or magnetic fields.

Unloading

Prepare special equipment for unloading. Avoid unloading outdoor in case of rain.

Location for Unloading

To select a location for safe unloading, check that:

- There is ample space for crane and forklift maneuvering.
- Ground is solid.
- The handrails of scaffold can be removed.
- There is enough working space for unpacking (at least 2500 mm by 4000 mm). Provide a platform if necessary.
- There is a height of at least 3000 mm under the roof.
- Outdoor-indoor temperature difference should be less than 10 °C to avoid condensation.

Keep Upright

Keep crates upright when unloading.

Avoid Physical Shock

Avoid physical shock. Be careful not to lose balance or swing when lifting or placing cargoes on the ground or platform. Also check scaffold strength.



CAUTION

- When lifting Hardware with a crane, do not unpack it, but attach lifting bolts or wire ropes to the baseboard positions shown to lift it. Keep the distance between the crane hook and the cargo to be lifted at a minimum.
- If it is difficult to do this, tie four belts together at a point close to the cargo to keep it from falling.
- Unpacked items are more likely to lose their balance and fall.

LPCKIT and YPCKIT with Crane

There are no eye bolts on top of LPCKIT/YPCKIT for lifting it. When lifting a LPCKIT or a YPCKIT with crane, use a baseboard with lifting bolts on front and rear, or use wire ropes (see figure). Labels indicating the center of gravity are attached at the both sides of the package.

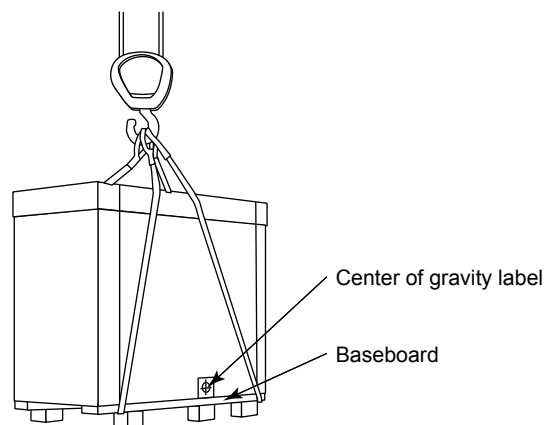

F020102.ai

Figure Lifting LPCKIT/YPCKIT with a Crane

Carrying

This section describes how to carry cabinets.

Carrying Space

Carry cabinets into the location of installation without unpacking.

To carry them in on the second floor or upper floors using a crane, a scaffold of about 2500 by 4000 mm is required for placing as well as unpacking.

Table Required Entrance and Elevator Size

	Console type HIS	Console type HIS (LCD Dual Stacked)	Cabinet
Width	800 mm	800 mm	800 mm
Height	1500 mm	1900 mm	2400 mm
Depth	1600 mm	1600 mm	1000 mm
Max. loading capacity	150 kg	200 kg	400 kg

Passage

The passage must be wide enough as shown below. It must also be strong enough to withstand the weight of the cabinet. Determine the passage according to the cabinet's and carrier's size and weight.

- Carrying console type HIS in

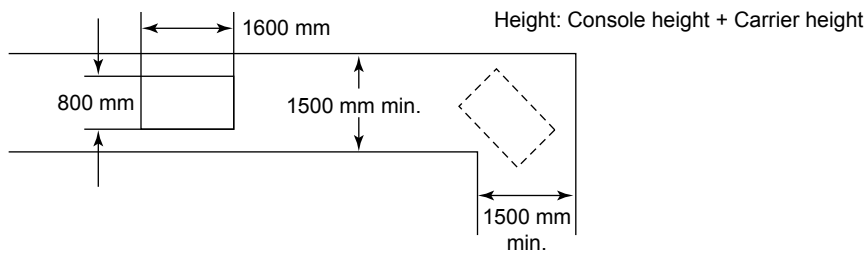

F020103.ai

- Carrying cabinet in

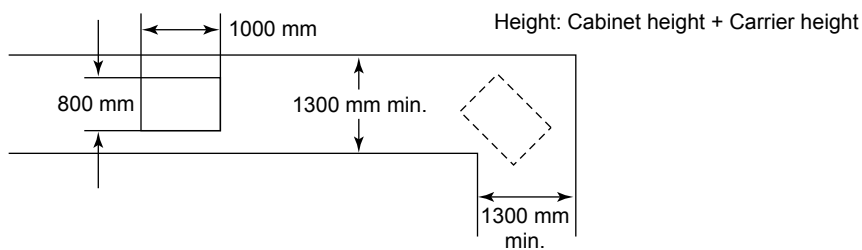

F020101.ai

Figure Passage Requirements

Carrying when Headroom is Low

The cabinet should be carried upright. If this is impossible due to low headroom,

- Remove the side boards.
- Turn the cabinet's right or left side (viewed from its front) down.
- Gently carry the cabinet with the side down.
- Turn the cabinet to its upright position as soon as the cabinet passes through a place with low headroom. Attach the side boards to the cabinet.

Using Rollers

The cabinet should be carried in to or near the installation location without unpacking. Do not use rollers if possible. When using them, take the following precautions:

- Use wooden rollers which are long enough so that more than 200 mm remains outside of the cabinet on each side.
- Make sure that two or more rollers are always under the cabinet.
- Do not use a hammer to correct roller positions on the move.

2.2 Unpacking

In unpacking the received cargoes and equipment, inspect them according to inspection list below. It is recommended to unpack by Yokogawa engineers or in their presence.

Table Inspection List

	Inspection Items	Result		Measures Required
Exterior	• Environment of unpacking location (temperature, humidity, dust)	Suitable	Unsuitable	If unsuitable, select proper location according to specified environmental requirements.
	• Rapid temperature fluctuation (should be within ± 10 °C/h)	No	Yes	If yes, do not unpack and wait until the fluctuation remains within ± 10 °C/h.
	• Damage to equipment exterior	No	Yes	If damaged badly, inform Yokogawa.
	• Condensation or its trace on equipment exterior. (*1)	No	Yes	If yes, inform Yokogawa.
Interior	• Loose parts inside equipment.	No	Yes	If yes, remove them and check the surrounding.
	• Damage to equipment interior.	No	Yes	If damaged badly, inform Yokogawa.
	• Condensation or its trace on equipment interior. (*1)	No	Yes	If yes, inform Yokogawa.

- *1: Condensation symptoms are as follows:
- Dew patterns on PCBs.
 - Printed circuit copper trace is floating off the board.
 - Label characters on PCBs are smudged.
 - Connectors on PCBs are smudged.
 - Dew patterns or traces of droplets are found on cabinet panels.



IMPORTANT

Condensation may cause a fatal system failure in the CS 3000 system. Be sure to unpack the equipment indoor under the specified environmental conditions. Strictly observe the allowable temperature fluctuation range of ± 10 °C/h. Do not bring the equipment into a heated room straight from the outside in winter. Our warranty does not cover any damage caused by condensation. Proper treatment may be able to minimize the damage caused by condensation, however. Contact Yokogawa in case of condensation.



IMPORTANT

Be careful not to let the products fall when you handle them.

When they are hit hard, the interior of them can be damaged, although there is no damage in the exterior.

If you accidentally drop an product, stop using it immediately and report it to YOKOGAWA or YOKOGAWA's service department.

Unpacking Procedure

[Unpacking export wooden crates]

Equipment packed for export is enclosed in an aluminized bag, then housed in a wooden crate.

To unpack export wooden crates:

- (1) Remove the nail from each corner protector.
- (2) Remove the nail from the ceiling panel.
- (3) Remove the nail from the upper brace.
- (4) Remove the nail from the side panel.
- (5) Remove the nail from the side panel.
- (6) Remove the nail from the end panel.

Sequencing steps (1) to (6) above remove nails from one side. Repeat them to remove nails from the opposite side.

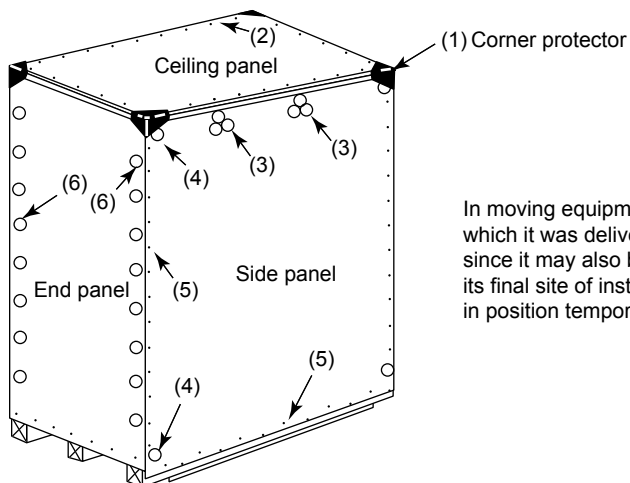

In moving equipment, carry it on the baseboard on which it was delivered for safety. Keep the baseboard since it may also be used to relocate equipment to its final site of installation after it has been installed in position temporarily.

F020201.ai

Figure Unpacking Procedure

2.3 Storage

The delivery date should be determined in accordance with your installation schedule. Avoid storing products more than three months. If long-term storage cannot be avoided, consult us in advance because it is necessary to provide waterproofing, condensation prevention, and dustproofing measures as well as periodical inspections.

Storage Condition

Store products without unpacking. Be sure to confirm that the crate is not damaged. To store them after unpacking, be sure to take the precautions described below.

Location of Storage

Store products in a warehouse or indoor facilities - never in an open-air location.

Storage Environment

- Avoid direct sunlight.
- Prevent condensation.
- Do not store products where corrosive gas or salty air may be present.

**SEE
ALSO**

See "Section 1.2 Control Room Environment" for permissible temperature, humidity and temperature fluctuation of storage area.

Storage of Packed Equipment

- Place squared pieces of lumber with a height of 100 mm or higher on the floor. The lumber should be long enough so that more than 100 mm remain outside of the crate on every side.
- Securely place unopened crates on the lumber platform.
- Do not stack crates in piles.
- Make sure to provide good air circulation in the storage area and periodically inspect the crates to keep them under proper conditions.

Storage of Unpacked Equipment

To store unpacked products without power connection, follow the specified environmental requirements. If stored in a non-air-conditioned room, cover them with polyethylene or other sheets for protection against dust and moisture. For moisture-proofing, place a sufficient amount of Silica gel or other desiccating agent inside the covering and inspect replace from time to time.

2.4 Servicing Area

Take enough space around equipment for its operation and maintenance service. This servicing area is indicated for each equipment.

The servicing area should be considered in determining the size of installation location. When installing a number of equipment side by side, take the largest service-area between them if different dimensions are indicated for different side of equipment (see below).

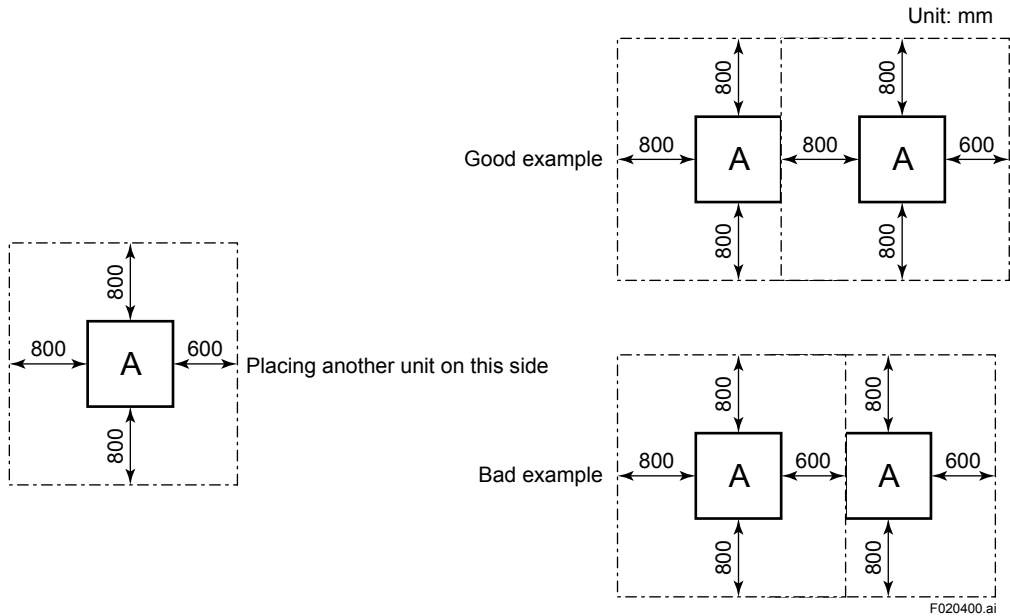

Figure Servicing Area when Installing Units Side-by-side

**SEE
ALSO**

For equipment servicing areas, refer to TI 33Q01J10-02E "External Dimensions."

2.5 Installation

Before installation, be sure that anchor bolts, pedestals, and cable holes are provided according to the customer's system configuration plans. Check that the positions of holes on the floor fit the anchor bolt holes in the channel base of each piece of equipment.

2.5.1 Installation on Floor

The installation method varies with the type of the floor and building.

- After unpacked, be careful not to put any impact until it is fixed to the floor to prevent from tip-over.
- Install devices as specified in the plans.
Check the position of front and back panels of the cabinet.
Avoid physical shock. Never use hammers.
- The open display style console assembly YPCKIT (excluding option code FT) is provided with simple legs. When the YPCKIT is secured to the floor, remove and store the simple legs. Use them at the time of movement in the future.
- Fix each equipment to the floor. The explanation below shows how to fix devices on different types of floors.

Concrete Floor

Clamp the equipment to the floor using anchor bolts. It is recommended to use M12 bolts and 3200 N•cm tightening torque.

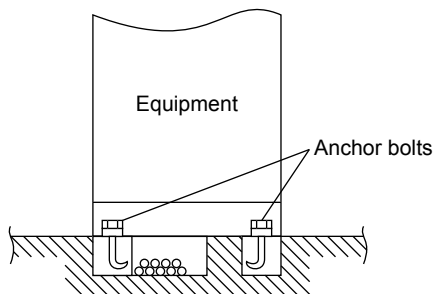

F020401.ai

Figure Using Anchor Bolts

Steel Floor

Clamp the equipment to the floor using clamp bolts.

After cabling through the riser duct, fill the duct with rubber sponges and seal the top with putty.

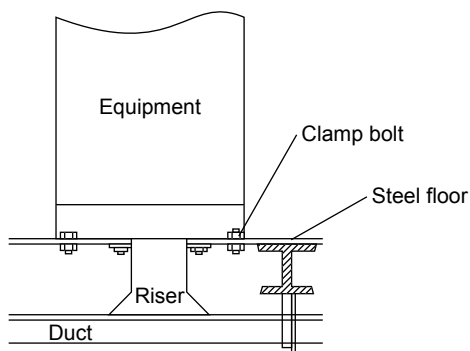

F020402.ai

Figure Using Clamp Bolts

“Free-access” Floor

Clamp the equipment to pedestals which are anchored to the base floor.

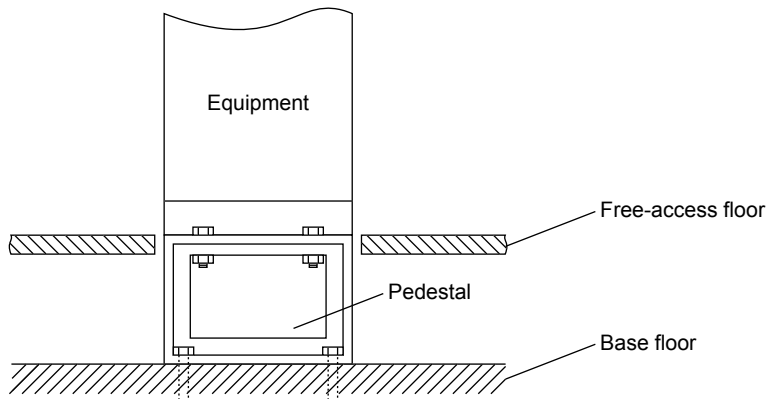

F020403.ai

Figure Using Pedestal

In the “free-access” floor, make holes for riser cables to connect to each piece of equipment as follows:

- If one floor tile is removed, be sure to reinforce the opening with an angle frame for floor stability.

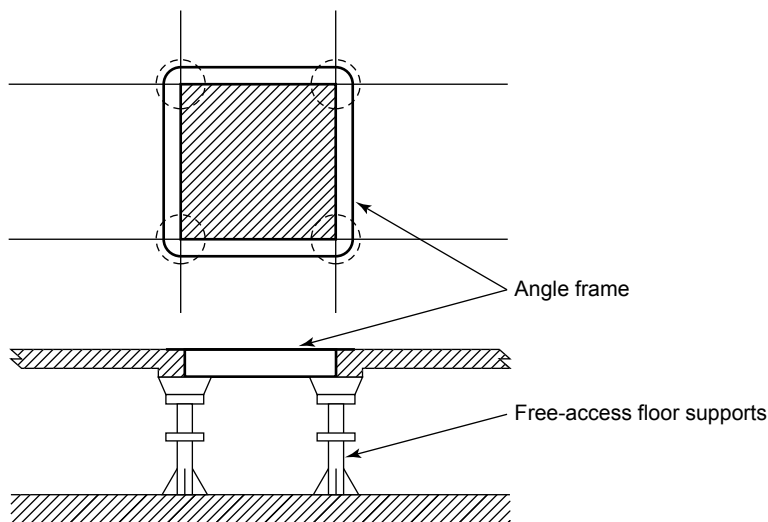

F020404.ai

Figure Removing One Floor Tile

- Do not make a holes near the floor supports.
- Do not cut away more than 1/3 of a floor tile.

**IMPORTANT**

If a number of neighboring floor tiles are removed, be sure to provide angle frames or pedestals for reinforcement.

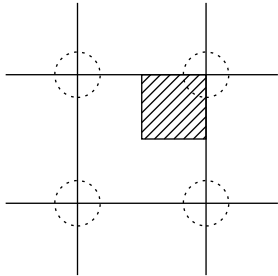

Bad example

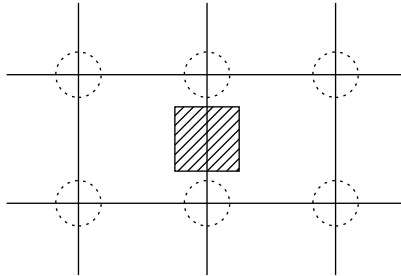

Good example

F020405.ai

Figure Partially Cutting Floor Tile

Size of Cabling Holes in Floor

For ease of cabling, and for separating power cables from signal cables, it is recommended that you create holes in the floor for cabling that are the maximum size indicated in the floor plans.

**SEE
ALSO**

Refer to "External Dimensions" (TI 33Q01J10-02E) for the weight and dimensions.

If the specified maximum size hole cannot be provided due to the floor construction or pit dimensions, the size may be smaller within the range indicated in the plans. If you use the specified minimum size of hole, use flexible cables that can bend inside the channel base.

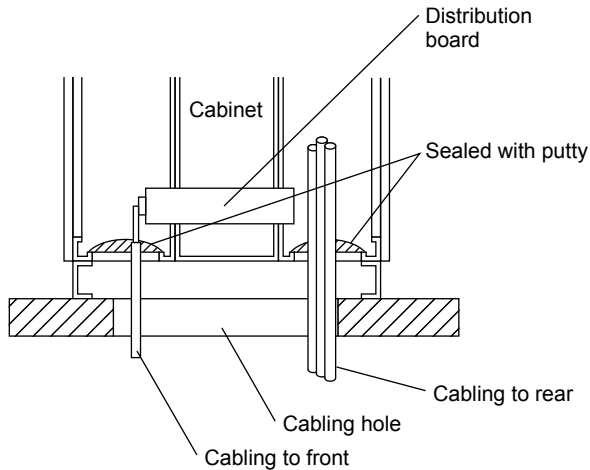

F020406.ai

Figure Cabling through Maximum Size Hole

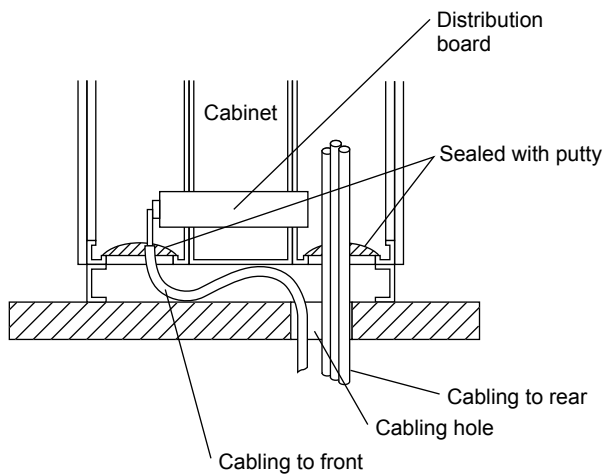

F020407.ai

Figure Cabling through Minimum Size Hole

2.5.2 Installing the Console Type HIS Side-by-Side

LPCKIT

The way to mount two or more console type HIS side by side, using bolts to join them, is described below. The same method is used to join universal consoles or CENTUM-XL cabinets with the same shape.



IMPORTANT

The CENTUM-XL EOPS has a different-shaped operation keyboard than the console type HIS, so you can't use the EOPS flat membrane keyboard if you want to mount EOPS and console type HIS side by side.

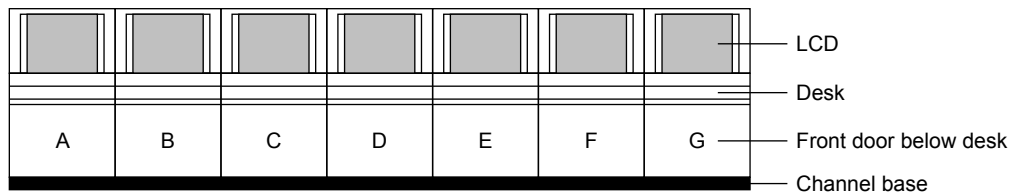

F020417.ai

Figure Example of side-by-side mounting of Console Type HIS

Installation

- (a) Level the floor surface on which cabinets are to be installed.
- (b) To install two or more cabinets in a line, install the central one first (D in Figure), and next ones on both sides (C→B→A, E→F→G).
- (c) With bottom plate (see Figure on next page) off, install the cabinet in position, making sure that the anchor bolt position and channel base hole align with each other.
- (d) Tighten anchor bolt nut (a) (see Figure on next page) when the installation is complete. When linking many cabinets in a row, tighten the nuts only finger-tight first, fully tightening them when the cabinet interconnection is complete.

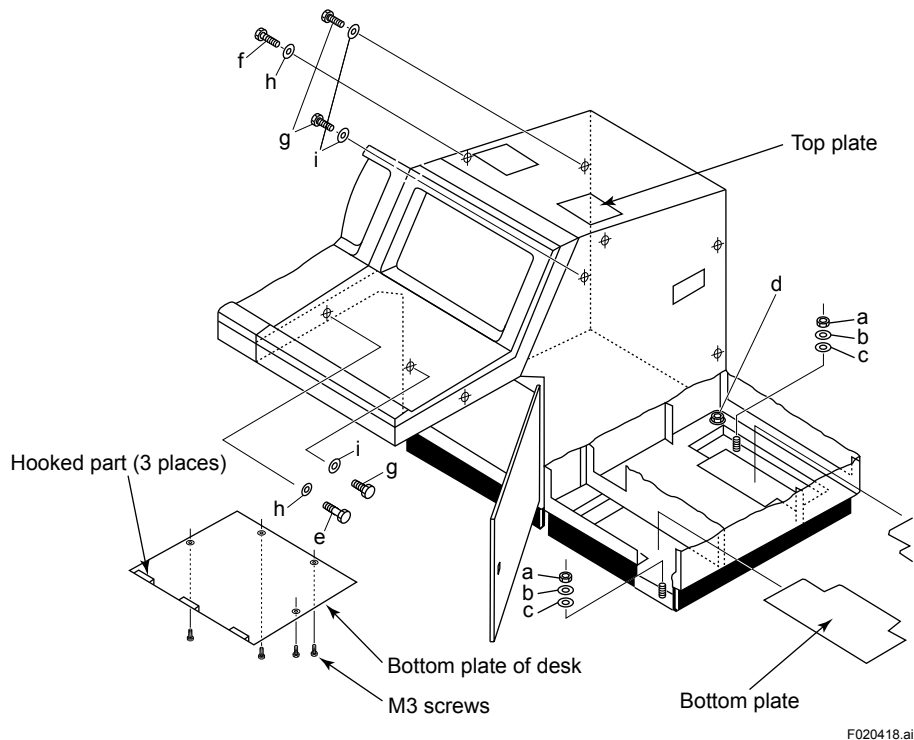

Figure Joining Parts and Tools for Interconnecting LPCKITs Side-by-Side

Referring to the figure above, follow the procedure described below to connect the HIS with bolts. When tightening bolts e, f, and g, make sure that console type HIS are aligned.

1. Using a hexagonal wrench, loosen hex socket head bolts d (4 bolts) securing the main body and the channel base to each other.
2. Remove the bottom place of desk, and tighten the tapered bolt screws e using an L-wrench j. To remove the bottom place of desk, remove the four M3 screws holding it – then you can slide the lower plate about 3 mm to the rear, lift the hooked part of the plate from the square holes in the lower part of the operator keyboard, and remove the plate from the bottom.
3. Remove the top plates and tighten tapered bolt screws with L-wrench k.
4. Open front and rear doors, and tighten bolt screws g with an L-wrench j.
5. Confirm that surfaces of the side-by-side HIS are aligned, then use a hex wrench to join main body to the channel base using hex bolts. If there's a gap between main body and channel base, insert liner.
6. Replace the removed plates and bottom plates in their original positions.

**SEE
ALSO**

For details on the related tools and parts for joining console-type HIS's side-by-side, refer to "Tools and Parts Required for Joining Console Type HIS side by side."



IMPORTANT

Don't pass wiring to non-Yokogawa equipment through the console type HIS. However, the wiring of PC or UPS installed in the console type HIS (LPCKIT, YPCKIT) is excluded.

YPCKIT

The way to mount two or more console type HIS side-by-side, using bolts to join them, is described below. The same method is used to join universal consoles or CENTUM-XL cabinets with the same shape.



IMPORTANT

The CENTUM-XL EOPS has a different-shaped operation keyboard than the console type HIS, so you can't use the EOPS flat membrane keyboard if you want to mount EOPS and console type HIS side-by-side.

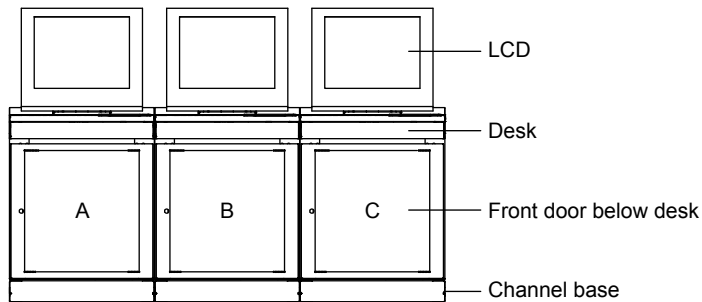

F020422.ai

Figure Example of Side-by-side mounting of Console Type HIS

Installation

- (a) Level the floor surface on which HISs are to be installed.
- (b) To install two or more HISs in a line, install the central one first (B in Figure), and next ones on both sides (C, A).
- (c) With bottom plate (see Figure on next page) off, install the HIS in position, making sure that the anchor bolt position and channel base hole align with each other.
- (d) Tighten anchor bolt nut (a) (see Figure on next page) when the installation is complete.
When linking many HISs in a row, tighten the nuts only finger-tight first, fully tightening them when the HIS interconnection is complete.

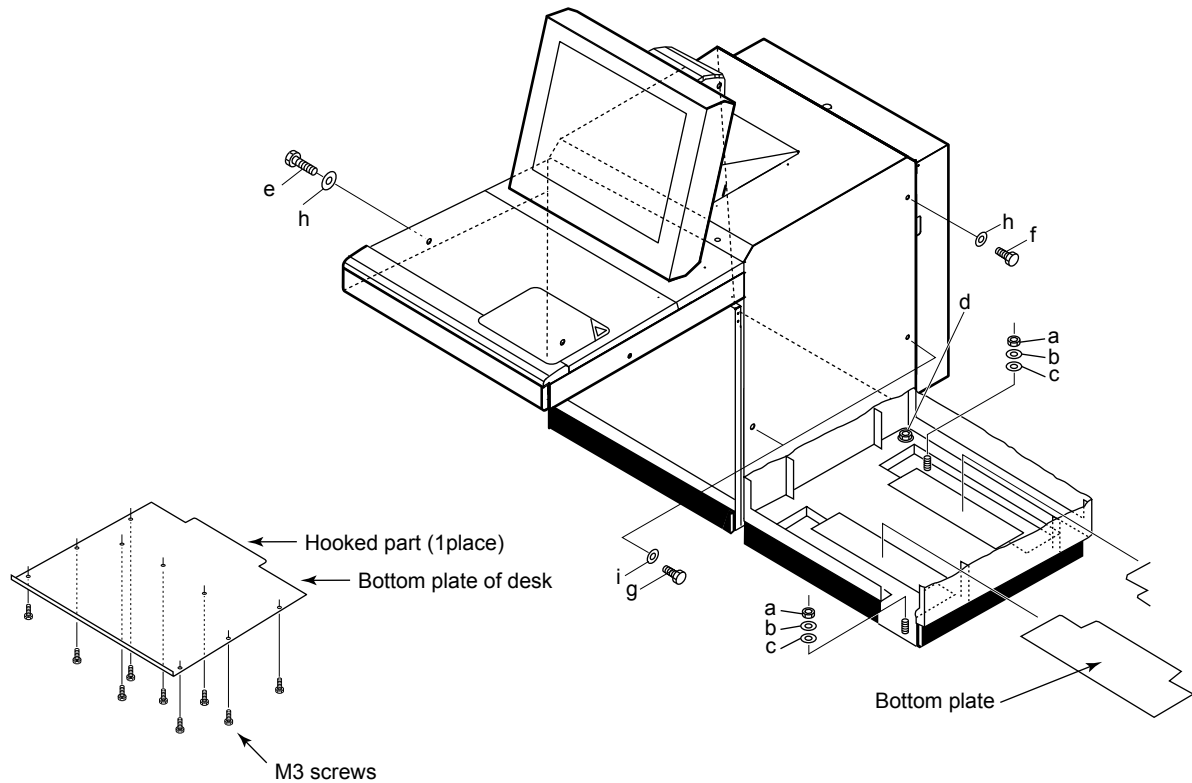

F020423.ai

Figure Joining Parts and Tools for Interconnecting YPCKITs Side-by-Side

Referring to the figure above, follow the procedure described below to connect the HIS with bolts. When tightening bolts e, f, and g, make sure that console type HIS are aligned.

1. Using a hexagonal wrench, loosen hex socket head bolts d (4 bolts) securing the main body and the channel base to each other.
2. Remove the bottom place of desk, and tighten the tapered bolt screws e using an L-wrench j. To remove the bottom plate of the desk, remove the nine M3 screws, pull the front side of the bottom plate down and pull the plate toward you. You can then release the hooked part of the plate and remove the operator keyboard from the bottom area.
3. Open front and rear doors, and tighten tapered bolt screws f with L-wrench k.
4. Tighten bolt screws g with an L-wrench j.
5. Confirm that surfaces of the side-by-side HIS are aligned, then use a hex wrench to join main body to the channel base using hex bolts. If there's a gap between main body and channel base, insert liner.
6. Replace the removed plates and bottom plates in their original positions.

**SEE
ALSO**

For details on the related tools and parts for joining console-type HIS's side-by-side, refer to "Tools and Parts Required for Joining Console Type HIS side by side."



IMPORTANT

Don't pass wiring to non-Yokogawa equipment through the console type HIS. However, the wiring of PC or UPS installed in the console type HIS is excluded.

Tools and Parts Required for Joining Console Type HIS side by side

Separately buy the kit of tools and parts for joining console type HIS (LPCKIT, YPCKIT) side by side.

The names and part numbers of kit components are shown below.

- AKT201 Connection kit for console type HIS (LPCKIT) for single display.
- AKT202 Connection kit for console type HIS (LPCKIT) for dual stacked display.
- AKT203 Connection kit for open display style console (YPCKIT), YAX801.

Table Tools and Parts Required for Joining a Pair of HIS

No.	Names	Part numbers	AKT201	AKT202	AKT203
a	Nuts and bolts (M12) (*1)	–	4	4	4
b	Spring washer (M12) (*1)	–	4	4	4
c	Flat washer (M12) (*1)	–	4	4	4
d	Hex-hole bolt (M10)	Y9035YX	4 (installed)	4 (installed)	4 (installed)
e	Tapered bolt screw (M8) (long)	T9009NS	1	1	1
f	Tapered bolt screw (M8) (short)	T9009NR	1	1	1
g	Bolt screw (M8)	Y9820NS	3	5	2
h	Flat washer (M10)	Y9100WS	2	2	2
i	Toothed (serrated) washer	Y9801WL	3	5	2
j	L-shaped hex wrench (long)	T9050QS	1	1	1
k	L-shaped hex wrench (short)	S9103PB	1	1	1

*1: Parts "a" "b" and "c" need to be provided by the user.

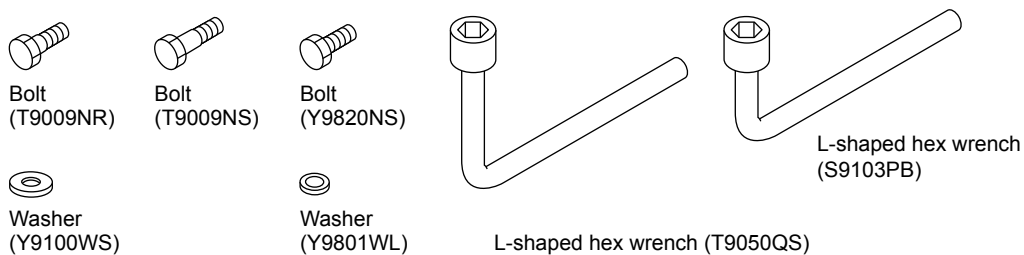

F020419.ai

Figure Kit for Joining Console Type HIS side by side

Location Where the UPS Is Installed

In the LPCKIT (Enclosed Display Style Console Type HIS), a space for a UPS can be specified as the option.

In the YPCKIT (Open Display Style Console Type HIS), there may not be sufficient space for a UPS depending on the PC to be used. In this case, prepare a space for the UPS if necessary.

2.5.3 Installing Cabinets in a Side-by-Side Arrangement

Install two or more cabinets in a side-by-side arrangement as described below.

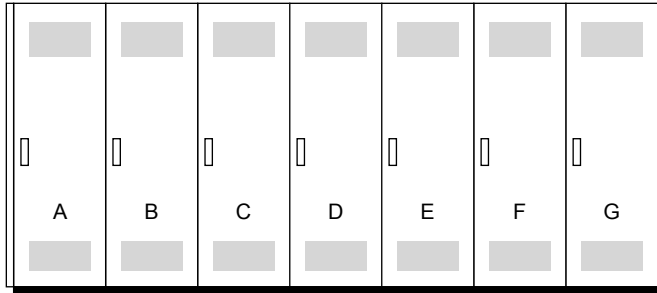
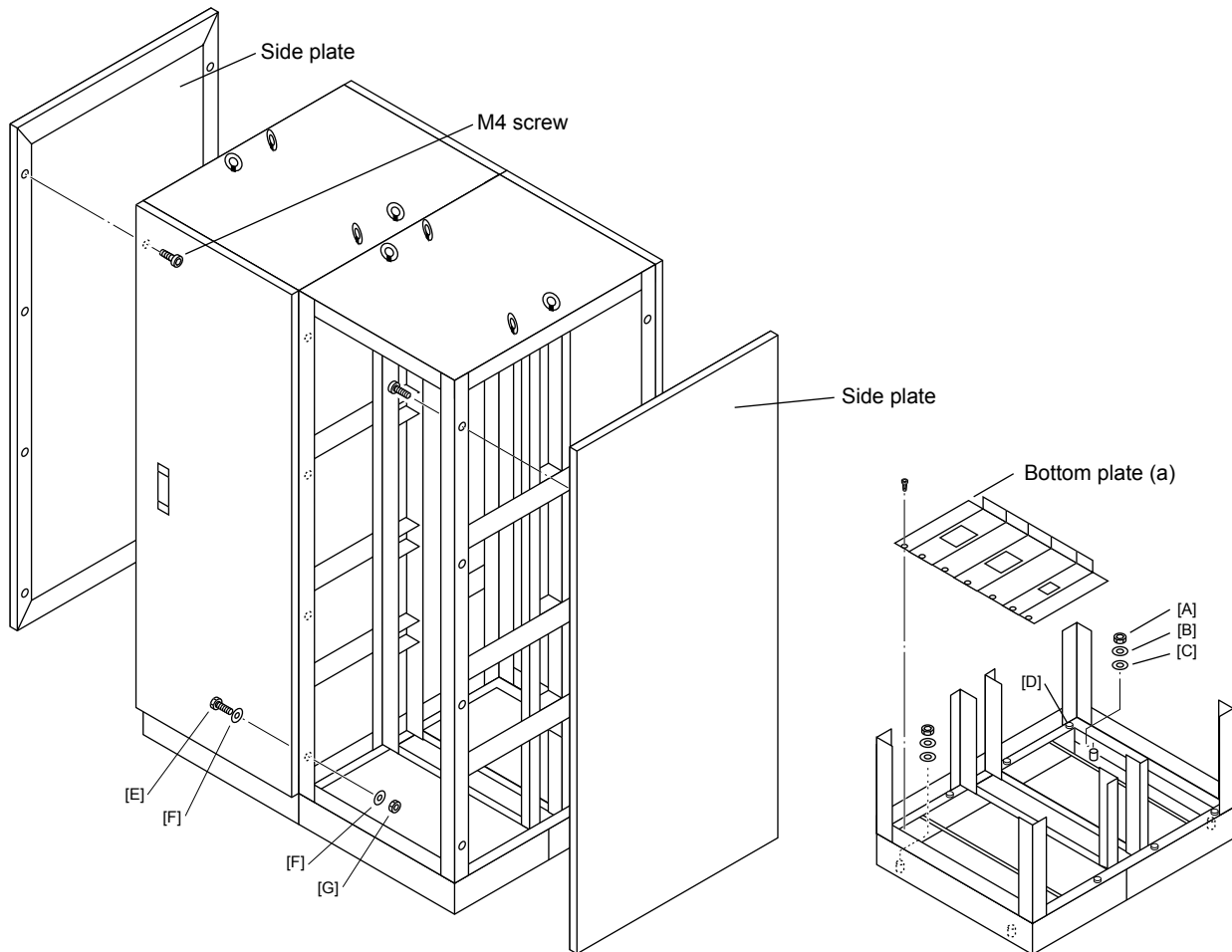

Figure Example of Installing Cabinets in a Side-by-Side Arrangement

Installation

- (a) Level the floor surface on which cabinets are to be installed.
- (b) To install two or more cabinets in a line, install the central one first (D in Figure), and next ones on both sides (C→B→A, E→F→G).
- (c) With bottom plate (a) (see Figure on next page) off, install the cabinet in position, making sure that the anchor bolt position and channel base hole align with each other.
- (d) Tighten anchor bolt nut [A] (see Figure on next page) when the installation is complete. When linking many cabinets in a row, tighten the nuts only finger-tight first, fully tightening them when the cabinet interconnection is complete.



F020409.ai

Figure Installing Cabinets Side by Side

Interconnecting cabinets

- (a) Using a hexagon wrench, loosen hexagonal socket head bolts [D] (eight bolts) securing the main body and the channel base to each other.
- (b) With the front and rear doors open, clamp bolt screw [E], toothed washer [F] and nut [G] using a wrench (at eight positions on the front and rear in total).
- (c) After verifying that the cabinet is level in all directions, clamp hexagonal socket head bolts [D] (eight bolts) securing the main body and the channel base to each other using a hexagonal wrench. If there is a gap between the main body and channel base when the hexagonal socket head bolts are clamped, insert liners into the gap for adjustment.
- (d) Replace all bottom plates that have been removed in their original position.

**SEE
ALSO**

For details on the related tools and parts for joining cabinet's side-by-side, refer to "Tools and Parts Required for Joining Cabinets."

Tools and Parts Required for Joining Cabinets

Connecting kit to install cabinets side by side. Table lists those parts needed to connect two cabinets together.

- AKT211: Connection kit for Cabinet

Table Joining Parts and Tools (required per additional station)

No.	Names	Part numbers	Quantity
a	Nut or bolt (M12) (*1)	–	4
b	Spring washer (M12) (*1)	–	4
c	Flat washer (M12) (*1)	–	4
d	Hex hole bolt (M10)	– (Cabinet accessory)	8
e	Bolt (M8)	Y9820NS	8
f	Toothed (serrated) washer (M8)	Y9801WL	16
g	Nut (M8)	Y9801BS	8
h	L-shaped hex wrench	S9103PB	2

*1: Parts "a" "b" and "c" need to be provided by the user.

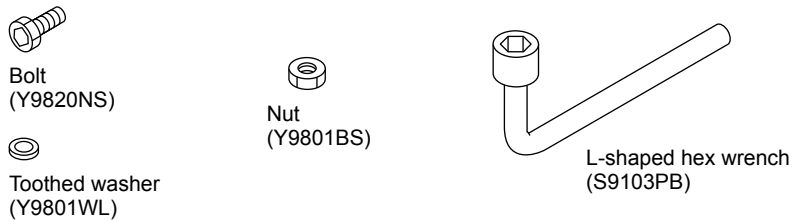

F020410.ai

Figure Cabinet Connecting Parts

2.5.4 19-inch Rack Mount Devices

Rack-mount devices include AFS30S/AFS30D, AFG30S/AFG30D, AFS10S/AFS10D, AFG10S/AFG10D, AFF50S/AFF50D Field Control Unit, PFCS/PFCD Control Station, YNT511S/YNT511D, YNT522S/YNT522D Optical Bus Repeater, YNT512S/YNT512D Bus Repeater, ACG10S Communication Gateway Unit, ANS50/AND50 Node Interface Unit, ANB10S/ANB10D, ANR10S/ANR10D Node Unit for FIO and ABC11S/ABC11D Bus Converter.



CAUTION

- Use 19-inch rack mount devices inside a keyed metallic cabinet, especially for Safety standard and CE Marking.
- Do not install the 19-inch rack mount devices close to each other. When installing an 19-inch rack mount devices on the same rack, maintain a 3-unit spacing (*1) (1 unit: 44.45 mm) between devices.

*1: Space between devices can be smaller than 3 U to the extent it does not interfere device mounting and maintenance, only if thermal design for the cabinet interior is done and ambient temperature is within the product specifications.

Notes on Installation



IMPORTANT

For installation, secure ample working space and work in a team for safety.

Be sure to observe the following when installing in the rack or on an instrumentation panel:

Attaching Brackets

There are the 19-inch rack mountable devices that the positions of their brackets can be changed according to the front and rear space of the rack. Before attaching the devices to the instrumentation panel or rack, change bracket positions as shown below, if necessary:

For example, the optical bus repeaters (YNT511S/YNT511D, YNT522S/YNT522D) and bus repeater (YNT512S/YNT512D) can be mounted in one of three positions located depth-wise.

The mounting bracket positions of the optical bus repeater are shown below.

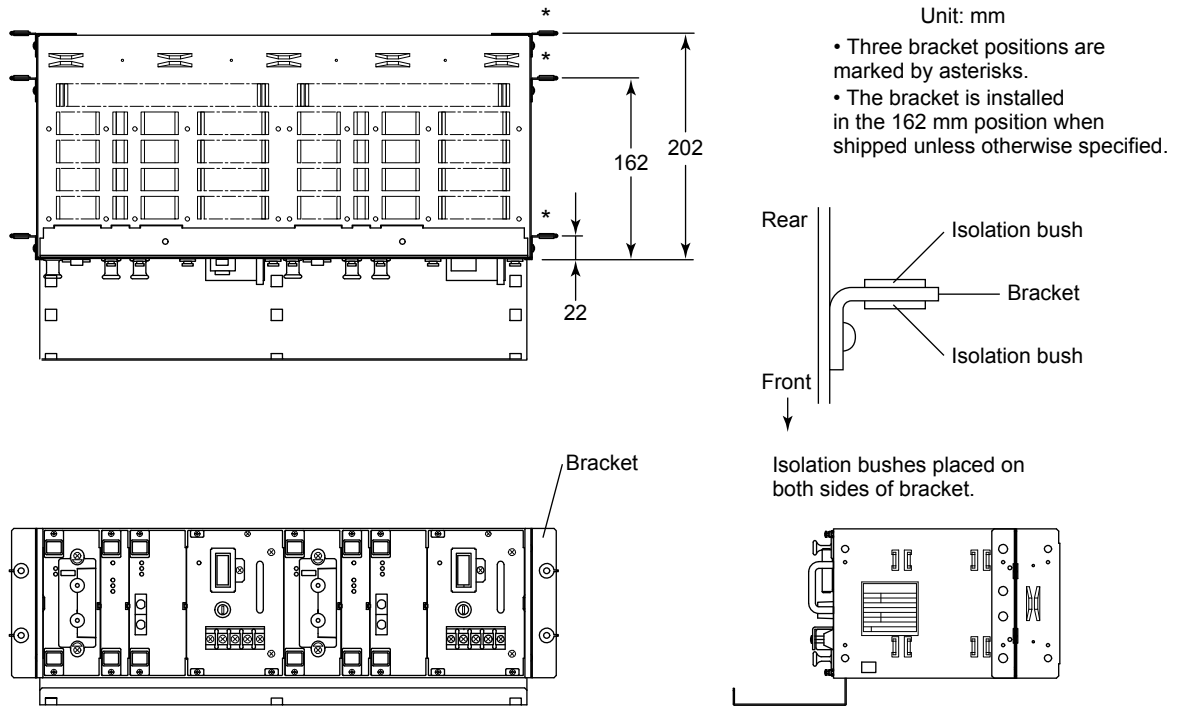

F020414.ai

Figure Mounting Bracket Positions of Optical Bus Repeater

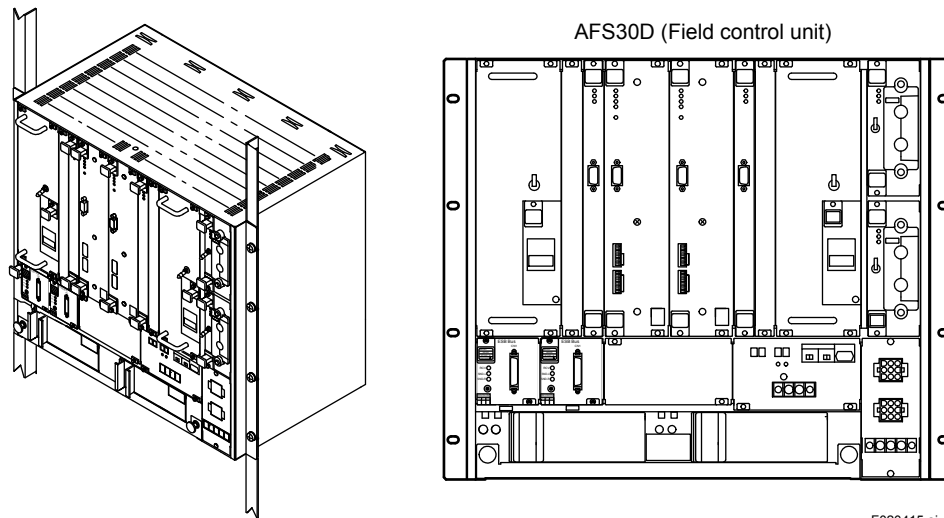

F020415.ai

Figure Example of AFS30D Installation

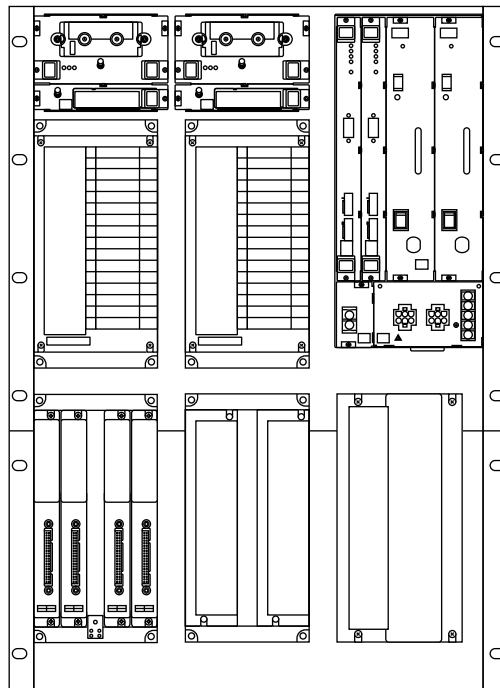
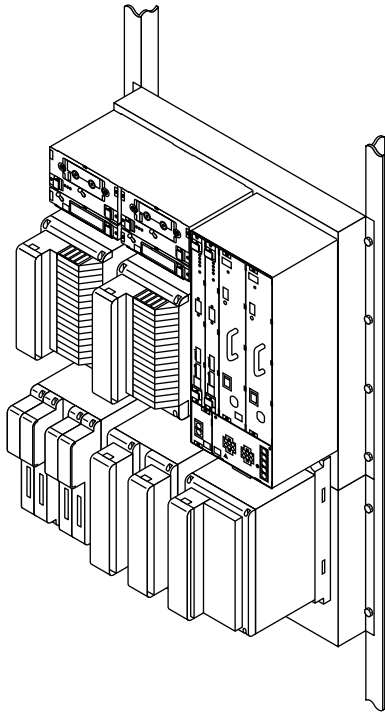

F020411.ai

Figure Example of PFCD Mounting

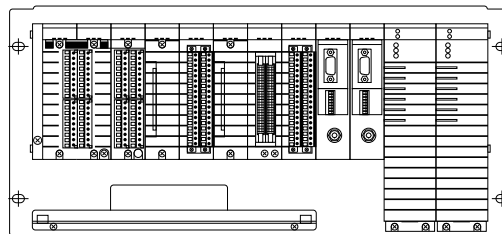
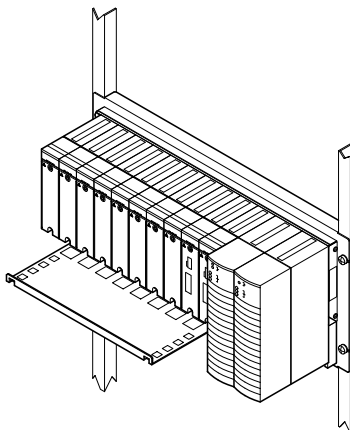

F020516.ai

Figure Example of ANR10D Mounting

Isolation from Rack

Isolate the rack mountable devices from the rack by attaching isolation bushings. Fasten a pair of isolation bushings together to each of the screw holes on the plate or the bracket on the devices to prevent the devices from touching the rack, and then screw the devices to the rack. After screwing the devices to the rack, confirm that the devices are electrically isolated. Isolation bushings are supplied with the rack mountable devices.



CAUTION

When you install the 'devices with isolation bushings attached' on a rack or an instrument panel, do not keep the devices hung on loose screws in an unstable status. Too much force may apply to the isolation bushings and cause damaged or broken isolation bushings.

Installation Procedure

1. Fasten a pair of isolation bushings together to each of the screw holes on the plate or the bracket on the device. The tapering end of the isolation bushings must come to the front side where a screw enters.
2. Using eight M5 screws to fix the device onto the rack or the panel.

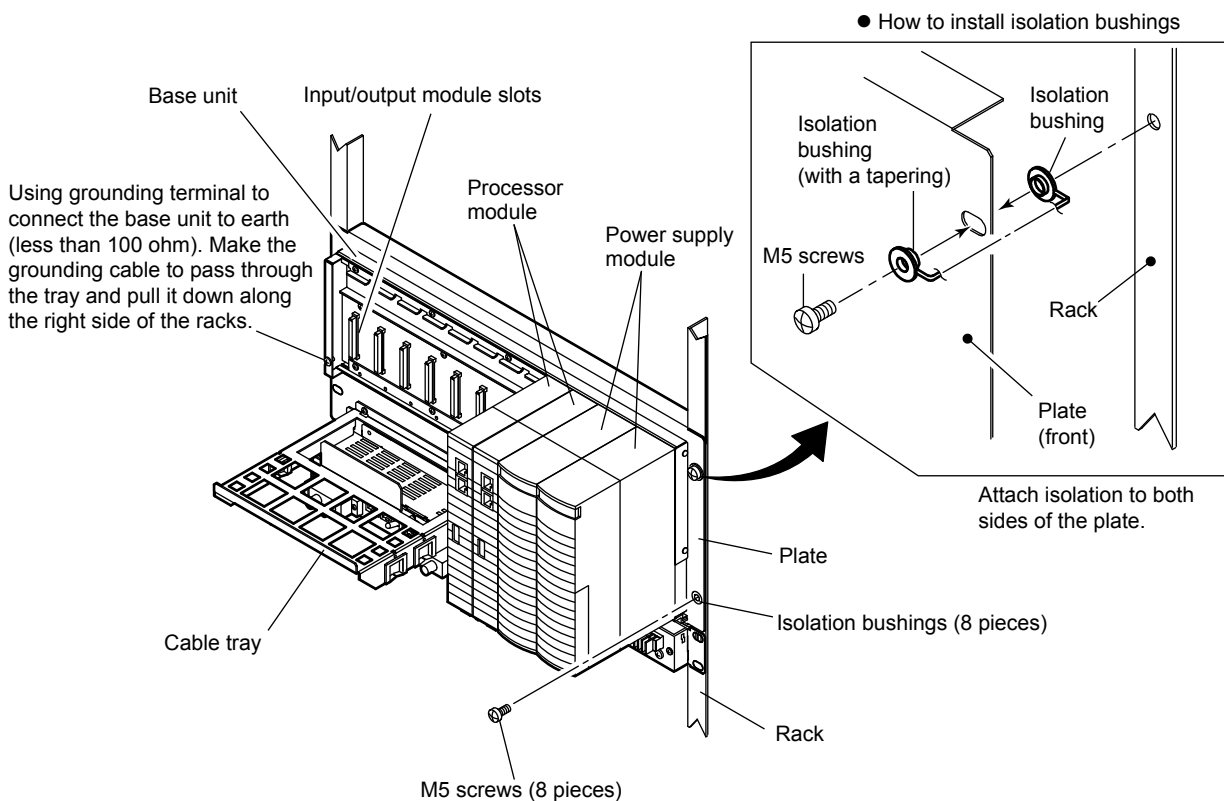

Figure Example of Mounting FFCS on a Rack

Isolation Bush

In the front of the I/O expansion cabinet (ACB21, ACB41): for cabinet installation type node and the rear: for 19-inch rack mount type (ACB□1-S2□□0), the cabinet installation type node is installed in the front. For this node, the independent grounding plays an important role in the circuit systems.

Therefore, in order that the rear 19-inch rack mount devices do not pass the grounding current which is important to the node, it and devices manufactured by other companies, must be insulated with an insulation bush. As devices manufactured by Yokogawa (Models ACG10S, ABC11S/ABC11D, etc.) also do not have the guarantee that it will share a common power supply or grounding with the Model ACB21 or ACB41 itself, make sure to insulate with an isolation bush.

In the front and rear of the I/O expansion cabinet: (ACB□1-S3□□0) installing 19-inch rack mount devices, the installed devices cannot restrict, similar in panels. Therefore, to ensure that problems will not occur whatever is connected to the grounding, insulate Yokogawa devices (Models ACG10S, ABC11S/ABC11D, etc.) with the isolation bush.

TIP

The isolation bush of Yokogawa devices can be eliminated if both I/O expansion cabinet types are installing Yokogawa devices (Models ACG10S, ABC11S/ABC11D, etc.) and shares a common power supply and grounding with Model ACB21, ACB41, and only when other company devices are insulated with an isolation bush.

Installation Direction

Install the device in the rack with the screws in the vertically correct direction.

Check the installation direction by referring to “External Dimensions (SD)”.

TIP

When the device is supplied with power even if it is temporary, the device must be installed on the rack. Placing the device on a desk etc. and laying it on its side should be avoided. The device may become malfunction if the heat radiated from the device cannot be cooled smoothly.

Providing Space for Heat Radiation

Leave space at the top and bottom of rack-mount equipment to permit heat radiation.

- Separate the top of the instrumentation board at least 100 mm away from the ceiling, and cut a ventilation hole of 200 cm² or larger in the ceiling or install a ventilation fan.
- Keep at least 50 mm between the back of the equipment and the instrumentation panel or wall.
- When installing an 19-inch rack mount devices on the same rack, maintain a 3-unit spacing (1 unit: 44.45 mm) between devices.
Do not use any space between equipments for cable wiring or anything.
- Do not block the ventilation openings in top and bottom face of equipment.

Providing Area for Servicing

Leave about at least 1000 mm of space at the front of the equipment for:

- Cabling to 19-inch rack mount devices, or I/O modules.
- Indicator lamp confirmation, making card settings, inspection, card mounting/dismounting, and maintenance.

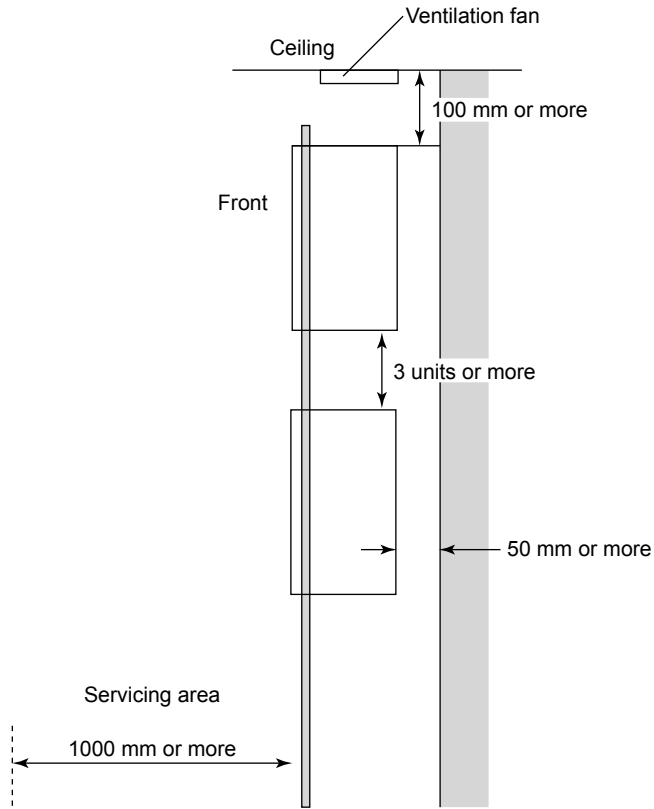

F020412.ai

Figure Space Required for Rack-mount Equipment

2.5.5 Desktop Equipment

There are general-purpose PCs, printers, etc. as the devices used on the desks.

When installing any devices on the desks, take care the followings:

- It should provide a level horizontal surface for the PC or the printer.
- A work space should be preserved to connect the cables.
- Support rising cables to prevent their weight from being applied to connectors directly. Keep a space of 100 mm radius or more around the connectors.
- Do not place the desk such as to expose the PC to direct sunlight or high humidity.

2.5.6 Desk (YAX101, YAX801)

This general-purpose desk (YAX101, YAX801) is ideal for the HIS (Human Interface Station and general-purpose PC).

This desk provides enough space on top for display, keyboard and mouse. The HIS CPU and a UPS can be mounted inside the desk (screw holes are pre-drilled).

An auxiliary power socket can be provided on the desk (option).

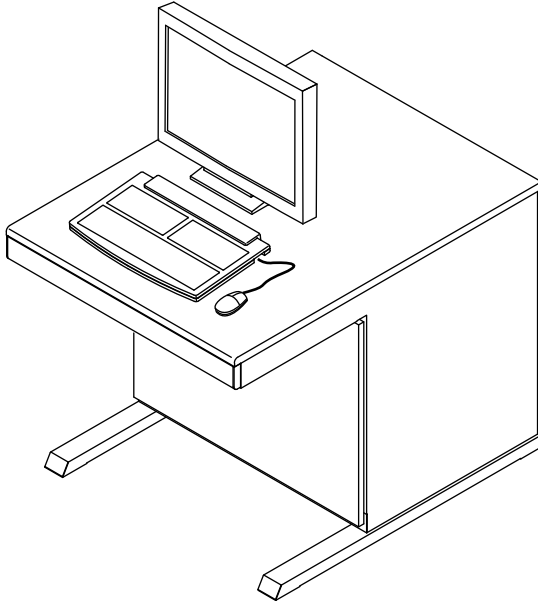

F020420.ai

Figure YAX101 Desk with Display, Keyboard and Mouse

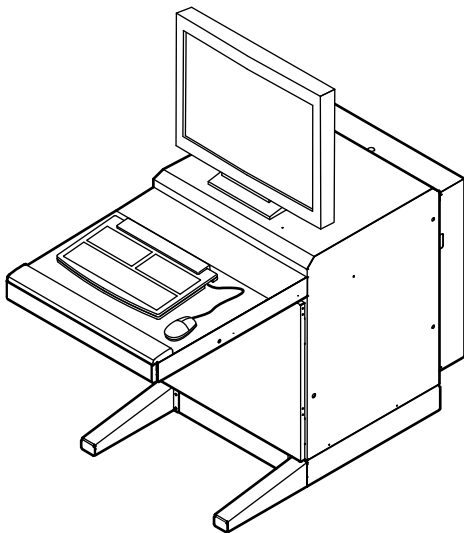

F020421.ai

Figure YAX801 Desk with Display, Keyboard and Mouse

2.5.7 Installing Control Bus Interface Card

This section describes how to install VF701 Control Bus interface card. The card is installed in the expansion PCI slot of a PC/AT compatible general-purpose PC to connect it to the Control Bus. The card permits you to use CENTUM CS 3000 system operation and monitoring functions on the PC when used with the dedicated software.

**SEE
ALSO**

- The steps described below are based on a common PC/AT compatible machine. Refer to the manual of the PC to be used for precise instructions.
 - For station address setting, refer to "Peripherals Manual (A4. Control Bus Interface Card)" (IM 33Y06G01-01E).
-

Card Installation Procedure

1. Set a station address for the Control Bus interface card.
2. Turn off the computer and unplug the power cord to ensure safety.
3. Remove the screws from the computer cover and remove the cover.
4. Remove the screws from the expansion card slot cover and remove the cover.
5. Insert the Control Bus interface card in the PCI expansion slot. Make certain that the card is properly set in the slot.
6. Clamp the Control Bus interface card using the screws removed in Step 4.
7. Attach the computer cover.
8. Write the station address on a seal (sticker) and attach it to the front of the PC or a similar highly-visible place.

**SEE
ALSO**

For electrostatic protection, refer to Item 1.5.2, "Countermeasures against Static Electricity."

3. Cabling

This section describes how to cable the installed system equipment.

Connecting terminals for power, grounding, and signal cables are shown in figures.

The figures also show how to connect the HIS-connected Control Bus interface card to Field Control Units, and an optical fiber cable to the optical bus repeater.

3.1 Cables and Terminals

It is recommended that you use flexible, thin, easy-to-bend, twisted-pair cables to connect the terminals of the system equipment. Use solderless (crimp-on) terminals with insulating cover, which have low contact resistance little aging.

Rigid cables make cabling work difficult and exert unnecessary force on the terminals, which may result in system failures.

Signal Cables

- Nominal conductor cross-sectional area: 0.75 to 2.00 mm²
 Example of Suitable Cables: 600 V vinyl isolated cable (IV); JIS C 3307
 Vinyl isolated wire (KIV); JIS C 3316
 600 V vinyl isolated cable type 2 (HIV); JIS C 3317
 Heat-proof vinyl isolated wire (UL1015/UL1007)
 Vinyl isolated sheath cable for control loop (CVV);
 JIS C 3401
- Solderless (crimp-on) terminal: Circular solderless terminal (for use with M4 screws)

Alarm and Control Circuit Cables

- Nominal conductor cross-sectional area: 0.5 to 1.25 mm²
 Example of Suitable Cables: 600 V vinyl isolated cable (IV); JIS C 3307
 Vinyl isolated wire (KIV); JIS C 3316
 Heat-proof vinyl-insulated wire (UL1007)
- Solderless (crimp-on) terminal: Circular solderless terminal (for use with M4 screws)

Power Cables

- Nominal conductor cross-sectional area
 For rack-mounted AC 100-120/220-240 V-driven equipment: 1.25 to 2.0 mm²
 For rack-mounted DC 24 V-driven equipment: Minimum 2.0 mm²
 For cabinets and console HISS: Minimum 8.0 mm²
 Example of suitable cables: 600 V vinyl isolated cable (IV); JIS C 3307
 Vinyl isolated wire (KIV); JIS C 3316
- Solderless (crimp-on) terminal lugs:
 Circular solderless terminal lugs for M4 or M6 screw terminal

Note: Use cables capable of supplying current required by respective pieces of equipment with low voltage drop.

Grounding Cables

SEE ALSO

See Section 1.4, "Grounding," for wiring of grounding cables connecting grounding bars of different cabinets and/or panels to each other.

- Nominal conductor cross-sectional area
 - For rack-mounted equipment: Minimum 2.0 mm²
 - Grounding cables connecting cabinets and console HISs to grounding bus: Minimum 5.5 mm²
 - Grounding buses connected to cabinets and console HISs: Minimum 22.0 mm²
- Example of suitable cables: 600 V vinyl isolated cable (IV); JIS C 3307
Vinyl insulated wire (KIV); JIS C 3316
- Solderless (crimp-on) terminal lugs
 - For rack mounted equipment: Circular solderless terminal lugs for M4 screw terminal
 - For cabinets and console HISs: Circular solderless terminal lugs for M5 or M8 hexagonal bolt

Cable Terminals

Use the specified solderless terminals and sleeves for pressure clamp terminal on the end of terminal-connected cables, providing low contact resistance, high durability, and low aging.

Solderless Lug



IMPORTANT

- Be sure to use solderless terminals with insulating sheath.
- Use solderless terminals and crimp tools from the same maker.
- Use different crimp tools according to cable size.

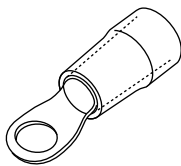

F030101.ai

Figure Solderless Terminal with Insulating Sheath

Sleeve for pressure clamp terminal

When connecting the process I/O signal to the pressure clamp terminal of FIO, strip the cable coating (without a sleeve) or attach a sleeve to the cable.

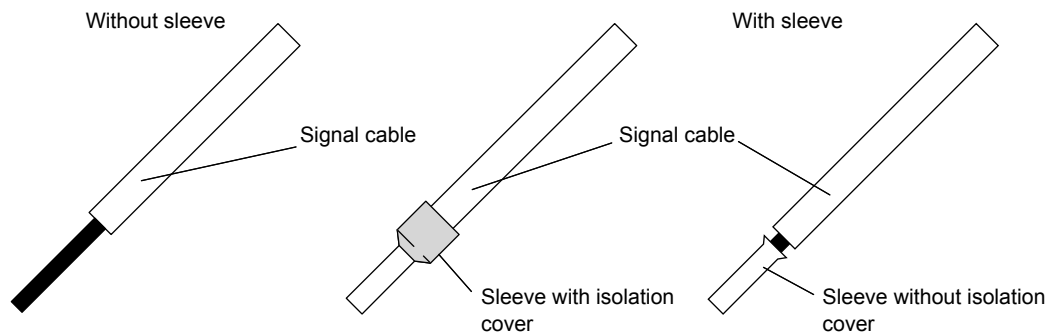

F030102.ai

Figure Sleeve for Pressure Clamp Terminal



IMPORTANT

- Use a sleeve for pressure clamp terminal and a clamp tool from the same manufacturer.
- Use a sleeve for pressure clamp terminal and a clamp tool which suit the cable thickness.

3.2 Connecting Power

Power is connected either by using a grounding-type bipolar (three-pin) plug or by wiring to terminals.

When piece of CS 3000 equipment has a power switch, it is recommended that you install a breaker for each piece of equipment in the same room, for maintenance and safety considerations.



CAUTION

- Power cables must be laid 1 cm or further away from signal cables.
- Power and grounding cable are use power and ground cables which are in conformance with the safety standard of each country.

Type and Maximum Length of Power Cables

Formulas are given below for determining the type and the maximum length (m) of branch cables from an indoor low-voltage main line.

- The standard type of cable used (nominal cross sectional area) is equivalent to JIS C 3312.
- Calculate the maximum power cable length from the following conditions in Figure. However, the power cable must meet the conditions described in Section “1.3 Power Supply System”, “AC Power Specification”.

AC wiring (100 V AC, 220 V AC)

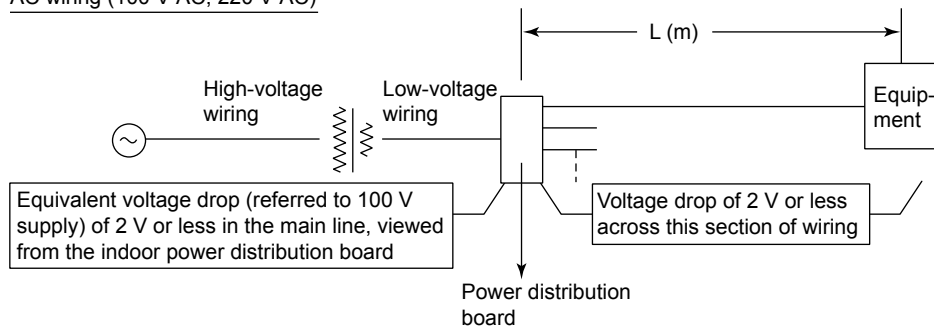

DC wiring (24 V DC)

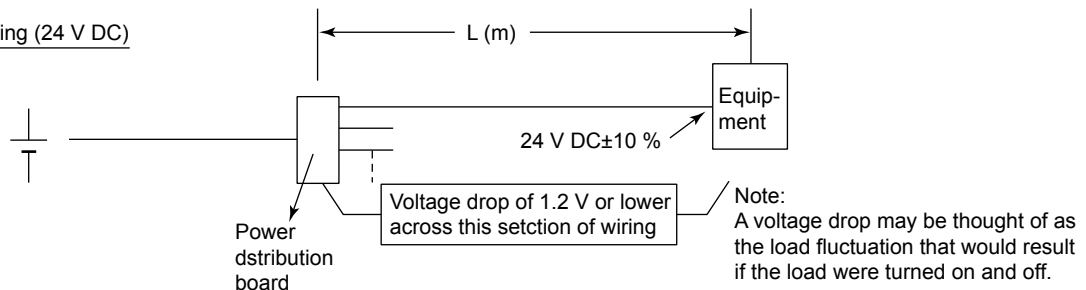

F030205.ai

Figure Maximum Cable Length Calculation Conditions

[Maximum power cable length calculation conditions]

Use the following formula to calculate the maximum power cable length:

(a) 100 V AC and 220 V AC supply voltages

$$L \text{ (m)} = \frac{\text{Voltage drop across wiring}}{\text{Conductor resistance (ohm/km)} \times (\text{Number of cores}) \times \text{Equipment current consumption}} \times 1000$$

F030206.ai

(b) 24 V DC supply voltage

$$L \text{ (m)} = \frac{\text{Voltage drop across wiring}}{\text{Conductor resistance (ohm/km)} \times (\text{Number of cores}) \times \text{Equipment current consumption}} \times 1000$$

F030207.ai

Note: In the formulas above, the voltage drop across wiring is assumed to be 2 V for AC power supplies and 1.2 V for DC power supplies; the number of cores is two; and the conductor resistance is as specified in the table below.

Table Wire Nominal Cross Sectional Areas and Resistances

Wire nominal cross sectional area	5.5 mm ²	8 mm ²	14 mm ²	22 mm ²
Wire conductor resistance	3.37 ohm/km	2.39 ohm/km	1.36 ohm/km	0.82 ohm/km

Power Cable Termination

Cable Termination

Use solderless lugs for power cables (see Figure).

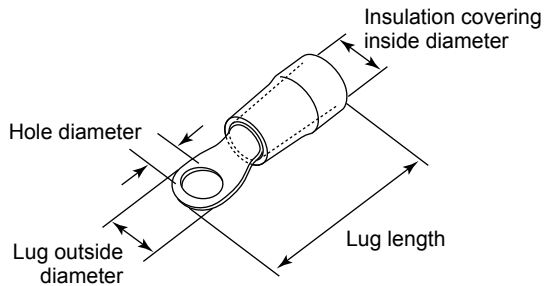

F030208.ai

Figure Solderless (crimp-on) Lug

Solderless (crimp-on) Lug Specifications

The solderless lug to use must have the dimensions given in table according to the nominal cross sectional area of the power cable for which the lug is to be used.

Table Solderless Lug Dimensions

Nominal cross sectional area (mm ²)	Screw used (mm)	Hole diameter (mm)	Lug outside diameter (mm)	Lug length (mm)	Insulation covering inside diameter (mm)
1.25	4	4.3 or more	8.2 or less	approx.21	3.6 or more
2.0	4	4.3 or more	8.7 or less	approx.21	4.3 or more
5.5	5	5.3 or more	9.7 or less	approx.29	5.9 or more
8.0	6	6.3 or more	12.2 or less	approx.41	7.0 or more
22.0	8 (hexagon head bolt)	8.3 or more	16.8 or less	approx.50	11.0 or more



IMPORTANT

- Always use solderless lugs with insulating covering.
- Always use solderless lugs and crimp-on tool manufactured by the same manufacturer.
- The crimp-on tool must be matched to the wire thickness.

Power Distribution Boards

Power distribution boards are normally provided by the customer. Figures show examples of AC and DC power distribution boards.

AC Power Distribution Board

The power cables is branched to each unit by way of a circuit breaker.

Each power system uses three terminals (AC and ground: ISO M4 to M6 screws).

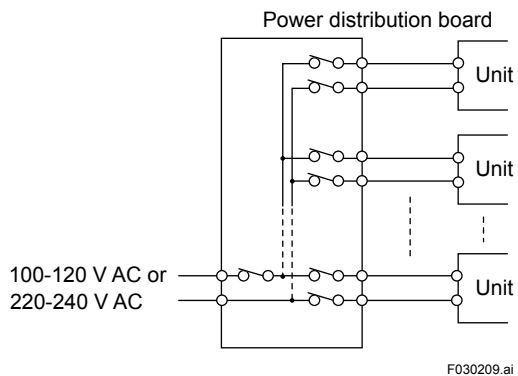

Figure AC Power Distribution Board

24 V DC Power Distribution Board

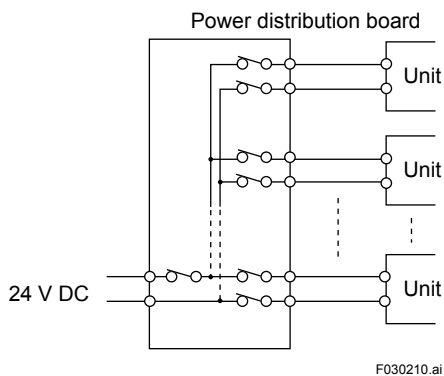

Figure 24 V DC Power Distribution Board

Three-pin Plug Connection

A general-purpose PC, an uninterruptible power supply (UPS), and ACG10S receive power through power cables with a three-pin plug.

A power cable is supplied with each device.

Most printers, and other peripherals use this type of power connection. Provide applicable sockets for the power plug.

The types of units listed below are powered by means of a two-pin plug (JIS C 8303). Provide a socket compatible with this plug.

The power cable is a standard accessory of the main body.

The table below lists examples of sockets compatible with the plug.

Table Examples of 100 V Power Supply Plug Receptacles

Manufacturer	Type	Part numbers	Description	Connection method	Rating
Matsushita Electric Works, Ltd.	Flush	WN1512K	Two-pin socket with flush ground (full terminal)	Attachment	15 A 125 V
	Surface	WK3004	Grounded double socket	Screw terminals	15 A 125 V
	Surface	WK3001	Grounded square socket (single)	Screwed terminals	15 A 125 V
Toshiba Corporation	Surface	DC1112EN	Square double socket with ground terminal	Screw terminals	15 A 125 V
	Surface	DC1111EN	Square socket with ground terminal (single)	Screw terminals	15 A 125 V

Terminal Connection

The power supply and grounding of the following devices are connected to the three terminals with M4 screws.

- AFS30S/AFS30D, AFG30S/AFG30D Field Control Unit (Rack Mountable Type)
- AFS10S/AFS10D, AFG10S/AFG10D Field Control Unit (Rack Mountable Type)
- AFF50S/AFF50D Field Control Unit (Rack Mountable Type)
- PFCS/PFCD Field Control Station
- YNT511S/YNT511D, YNT522S/YNT522D Optical Bus Repeater
- YNT512S/YNT512D Bus Repeater
- ACG10S Communication Gateway Unit (Rack Mountable Type)
- ABC11S/ABC11D Bus Converter (Rack Mountable Type)

The power supply of the following devices is connected with M6 screws, and they are grounded to a grounding bar with M5 screws. At delivery, control units are installed in a cabinet and connected through the power distribution board in the cabinet.

- LPCKIT, YPCKIT console type HIS
- AFS40S/AFS40D, AFG40S/AFG40D Field Control Unit (with cabinet)
- AFS20S/AFS20D, AFG20S/AFG20D Field Control Unit (with cabinet)
- ACB21, ACB41 I/O Expansion Cabinet

Conduit Power-cabling

Conduit cabling using cable glands is recommended to lay a power cable for the cabinet and instrumentation boards. It prevents the power cable from contacting metallic plates and putting its weight on power connection terminal.

The console type HIS, or cabinet, has a conduit hole in the bottom plate directly below the terminal box, and the hole can be exposed by removing the blank plate screwed to the bottom. See figures below for conduit cabling:

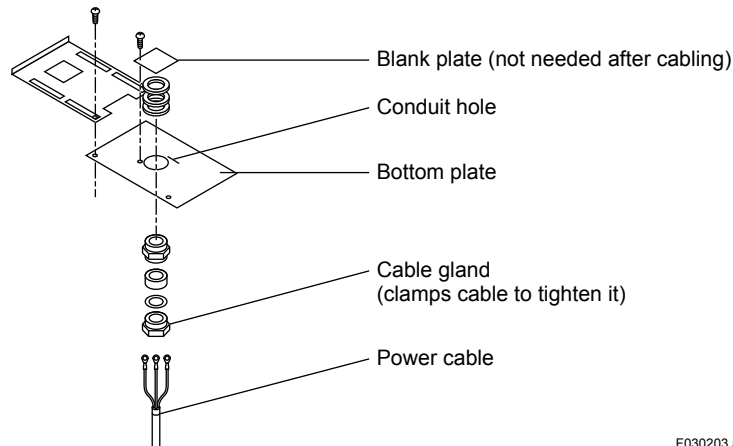

Figure Conduit Hole & Cable Gland

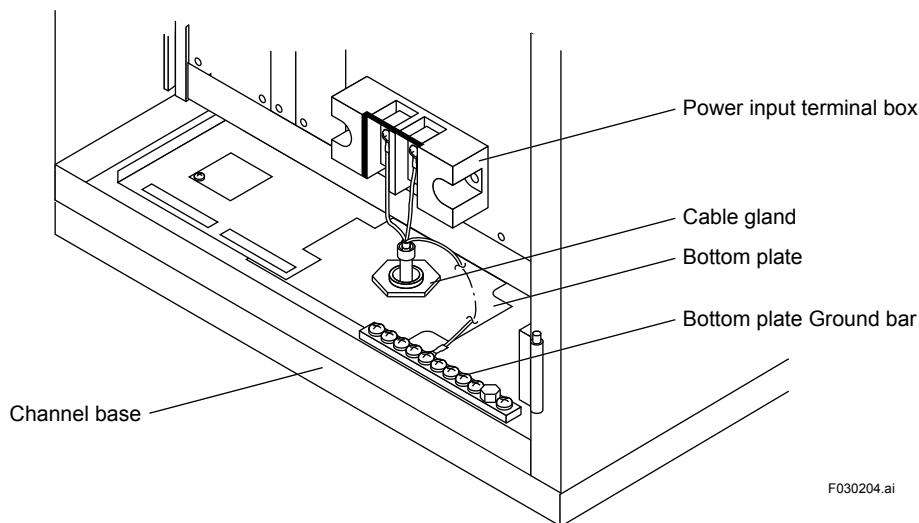

Figure Conduit Cabling

Conduit cabling is also recommended for the 19-inch rack-mount equipment, laying a power cable through a conduit hole where the cable enters the metallic cabinet.

3.3 Connecting Ground Cable

Connect ground cables as follows:



CAUTION

- Connect the terminal connection type device to the ground terminal.
 - Connect LPCKIT, YPCKIT, AFS40S/AFS40D, AFG40S/AFG40D, AFS20S/AFS20D, AFG20S/AFG20D, ACB41, and ACB21 to the relay terminal of the ground bar for connecting a ground cable with M5 screws.
 - Connect a power cable of the plug-in device to a grounded socket. The cabinet is grounded when the power cable is plugged in.
-

3.4 Power and Ground Cabling

The following figures illustrate how to connect a power and grounding cable with each system equipment.

Enclosed Display Style Console Assembly (LPCKIT)

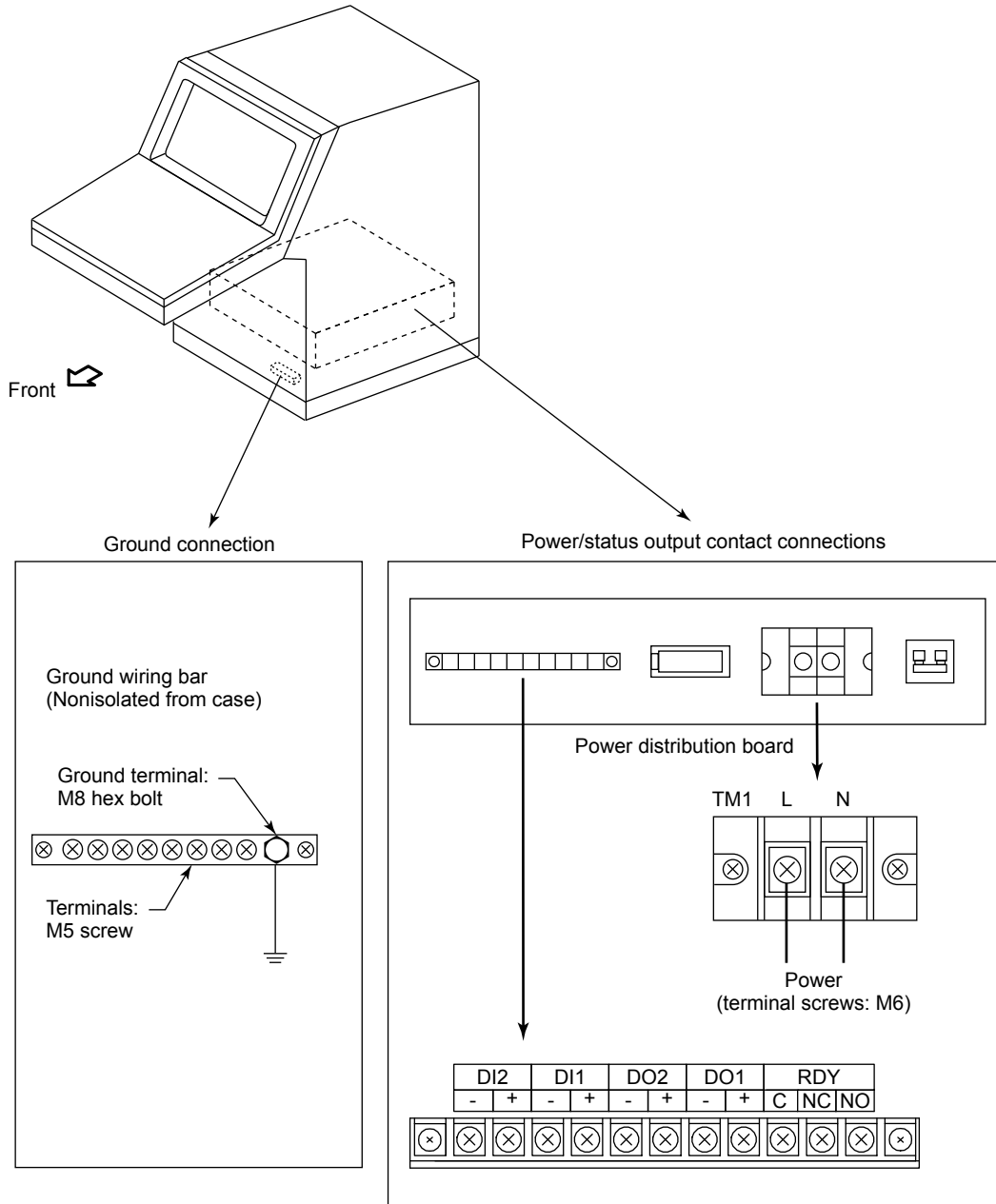

F030401.ai

Figure LPCKIT Cable Connections

Open Display Style Console Assembly (YPCKIT)

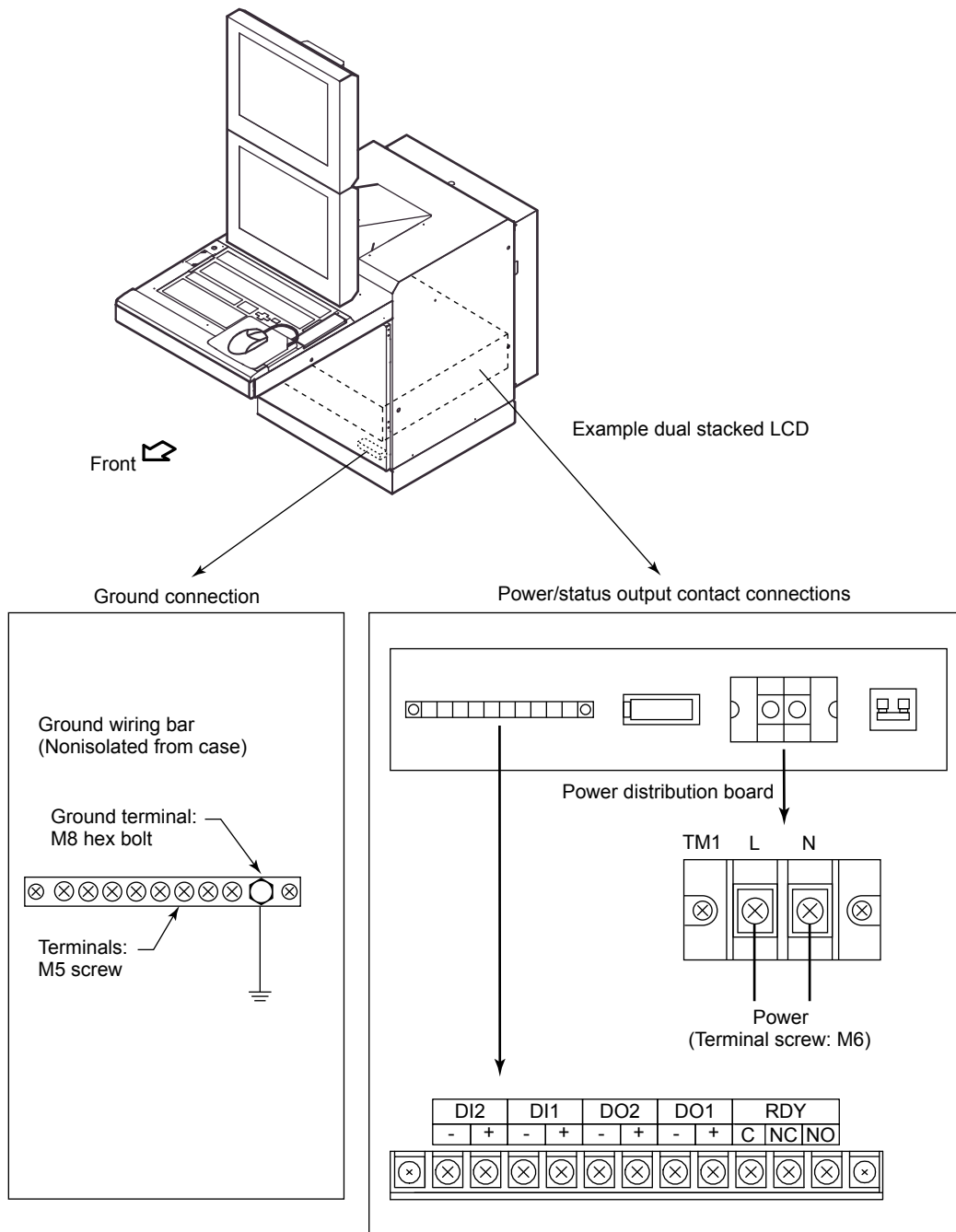

F030402.ai

Figure YPCKIT Cable Connection

AFS10S/AFS10D, AFG10S/AFG10D Field Control Unit (19-inch Rack Mountable Type)

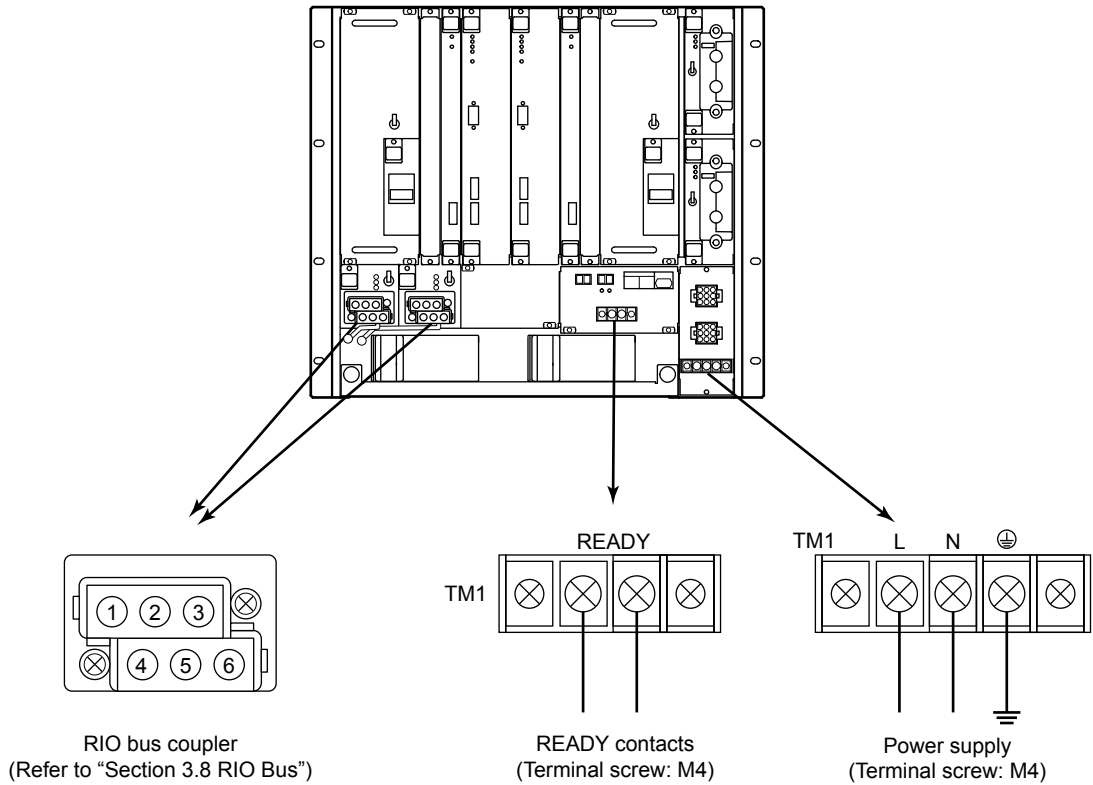

F030409.ai

Figure AFS10S/AFS10D, AFG10S/AFG10D Cable Connections



IMPORTANT

If wiring the contact output cable to the READY contact output terminals, attach a clamp filter (part No. A1193MN with cable fastener) supplied with AFS10S/AFS10D and AFG10S/AFG10D, near the terminals.
This inside diameter of the core is 9 ± 1 mm.

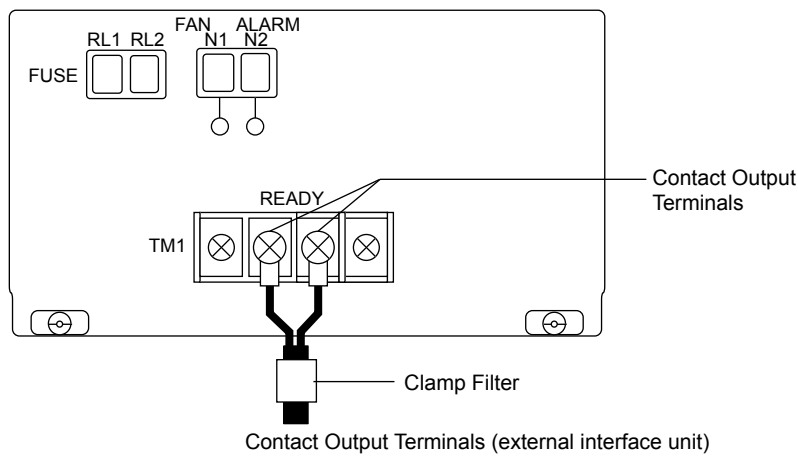

F030410.ai

Figure Clamp Filter

AFS30S/AFS30D, AFG30S/AFG30D Field Control Unit (19-inch Rack Mountable Type)

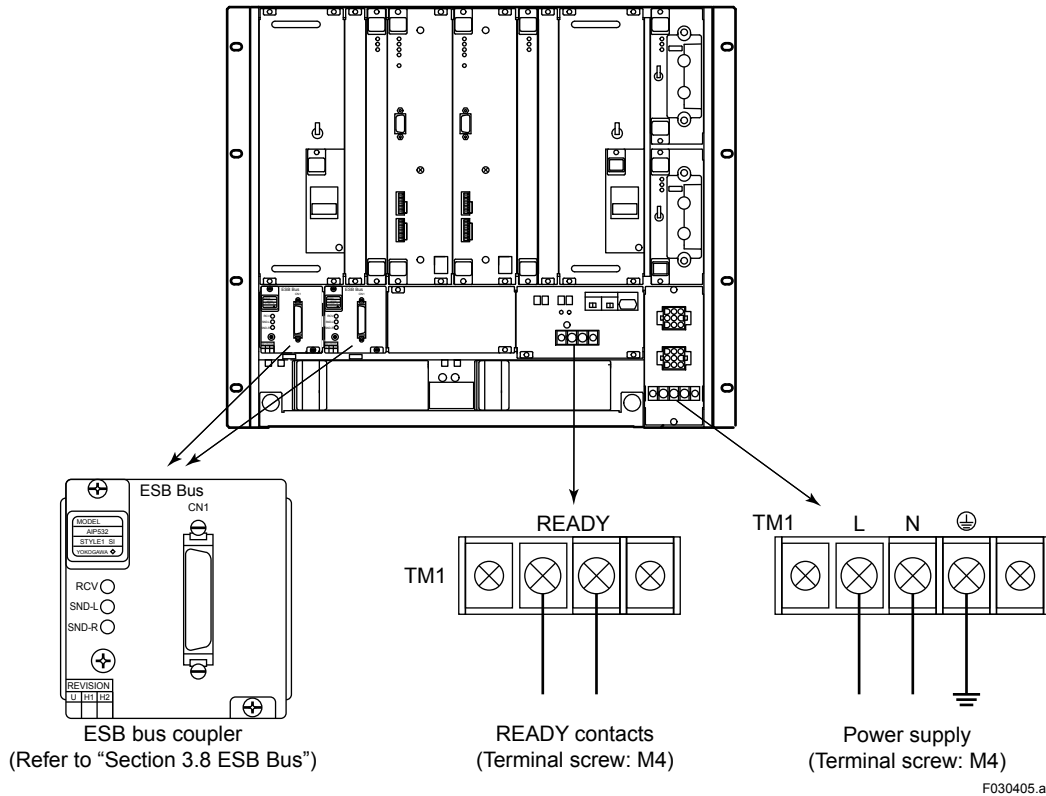

Figure AFS30S/AFS30D, AFG30S/AFG30D Cable Connections



IMPORTANT

If wiring the contact output cable to the READY contact output terminals, attach a clamp filter (part No. A1193MN with cable fastener) supplied with AFS30S/AFS30D and AFG30S/AFG30D, near the terminals.
This inside diameter of the core is 9±1 mm.

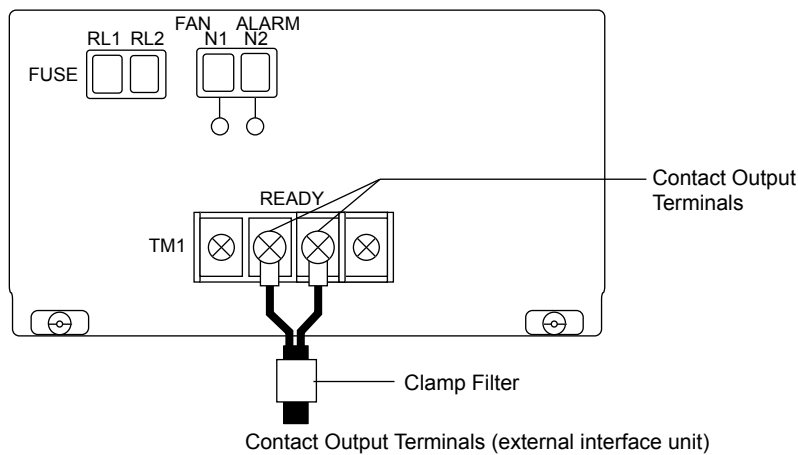
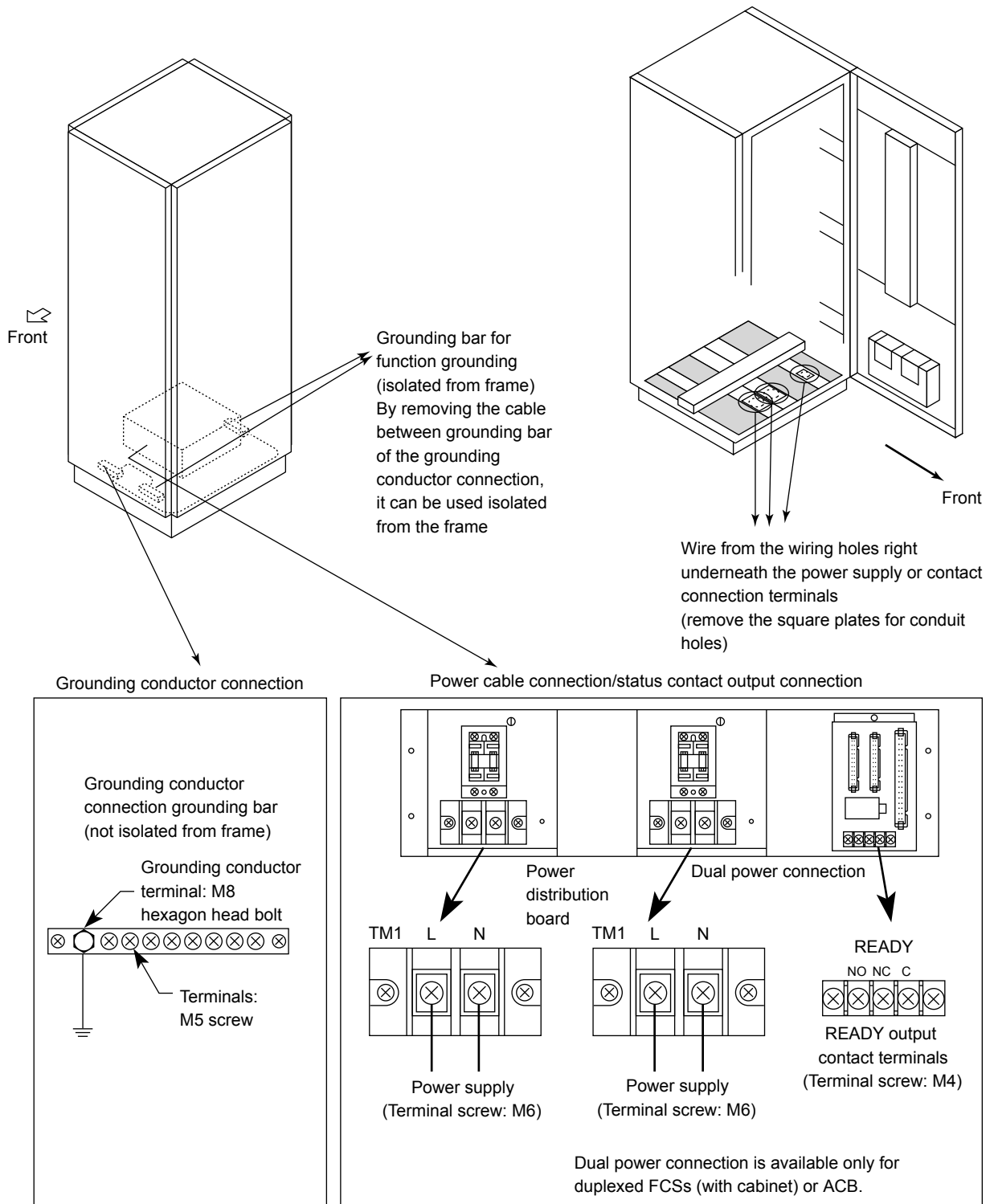

Figure Clamp Filter

**AFS20S/AFS20D, AFG20S/AFG20D Field Control Unit (with Cabinet),
AFS40S/AFS40D, AFG40S/AFG40D Field Control Unit (with Cabinet)
ACB21 I/O Expansion Cabinet, ACB41 I/O Expansion Cabinet**



F030411.ai

Figure Cabinet Cable Connections

AFF50S/AFF50D Field Control Unit (19-inch Rack Mountable Type)

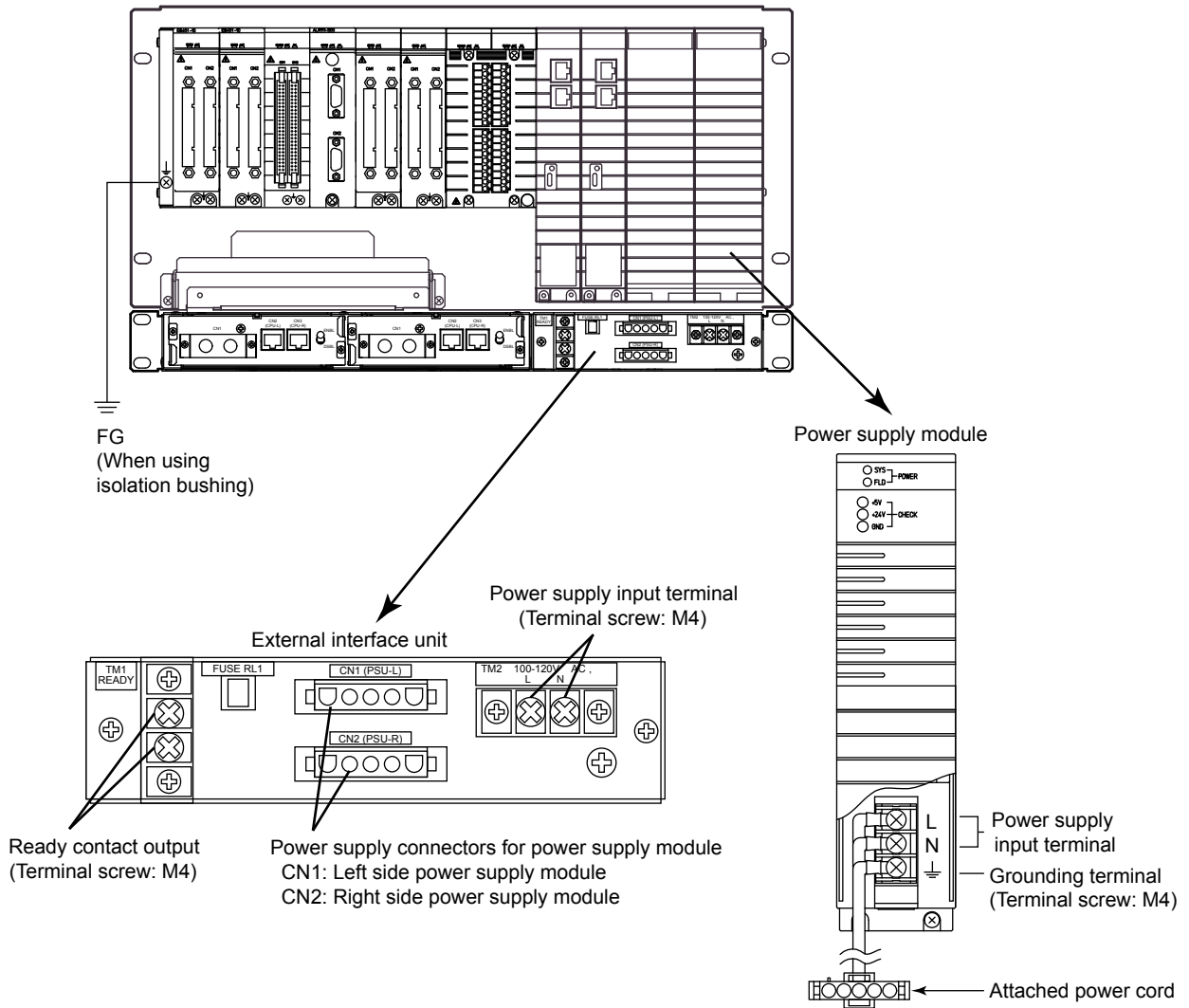

Figure AFF50S/AFF50D Power Cable Connections

F030421.ai

PFCS/PFCD Field Control Station

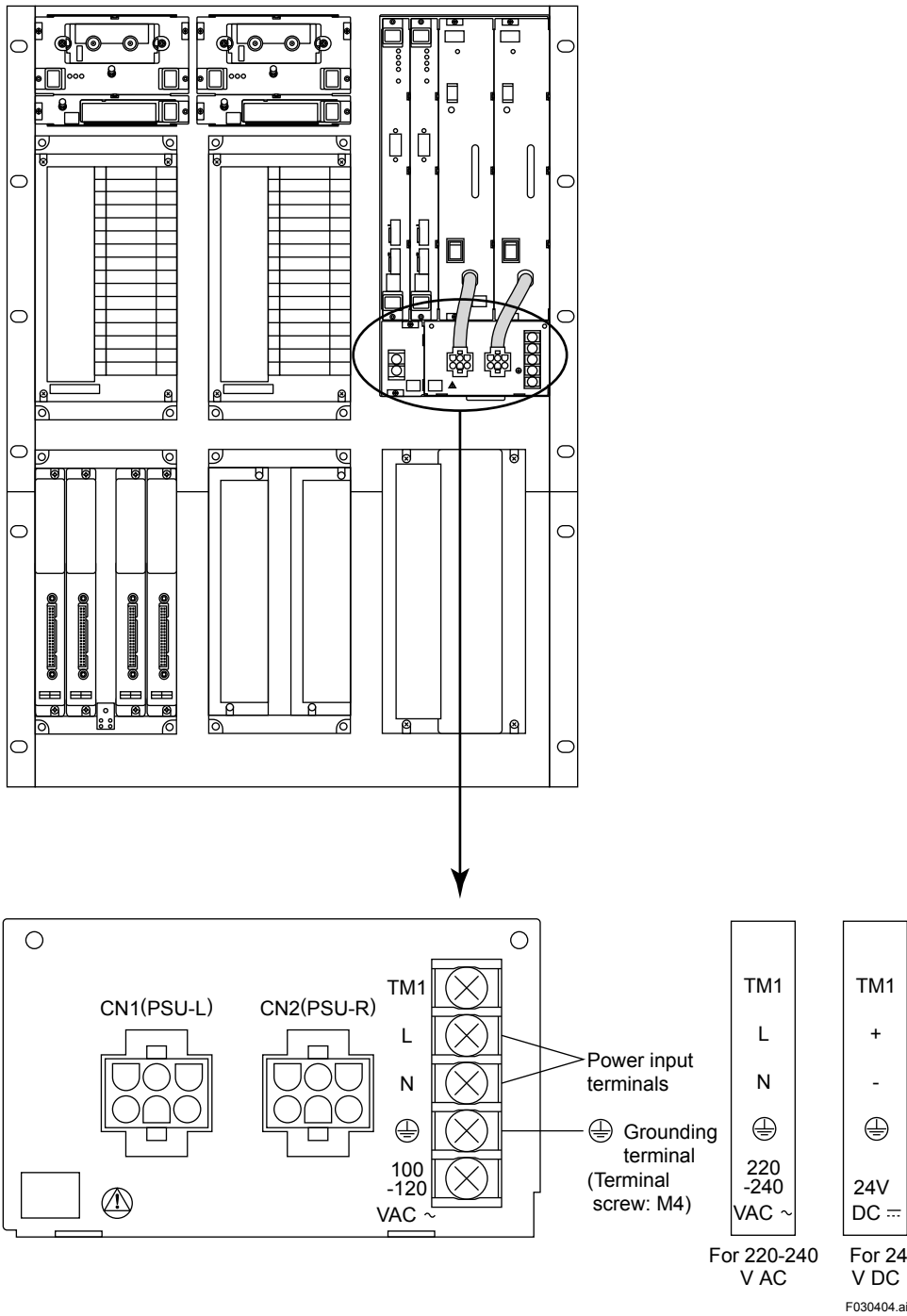
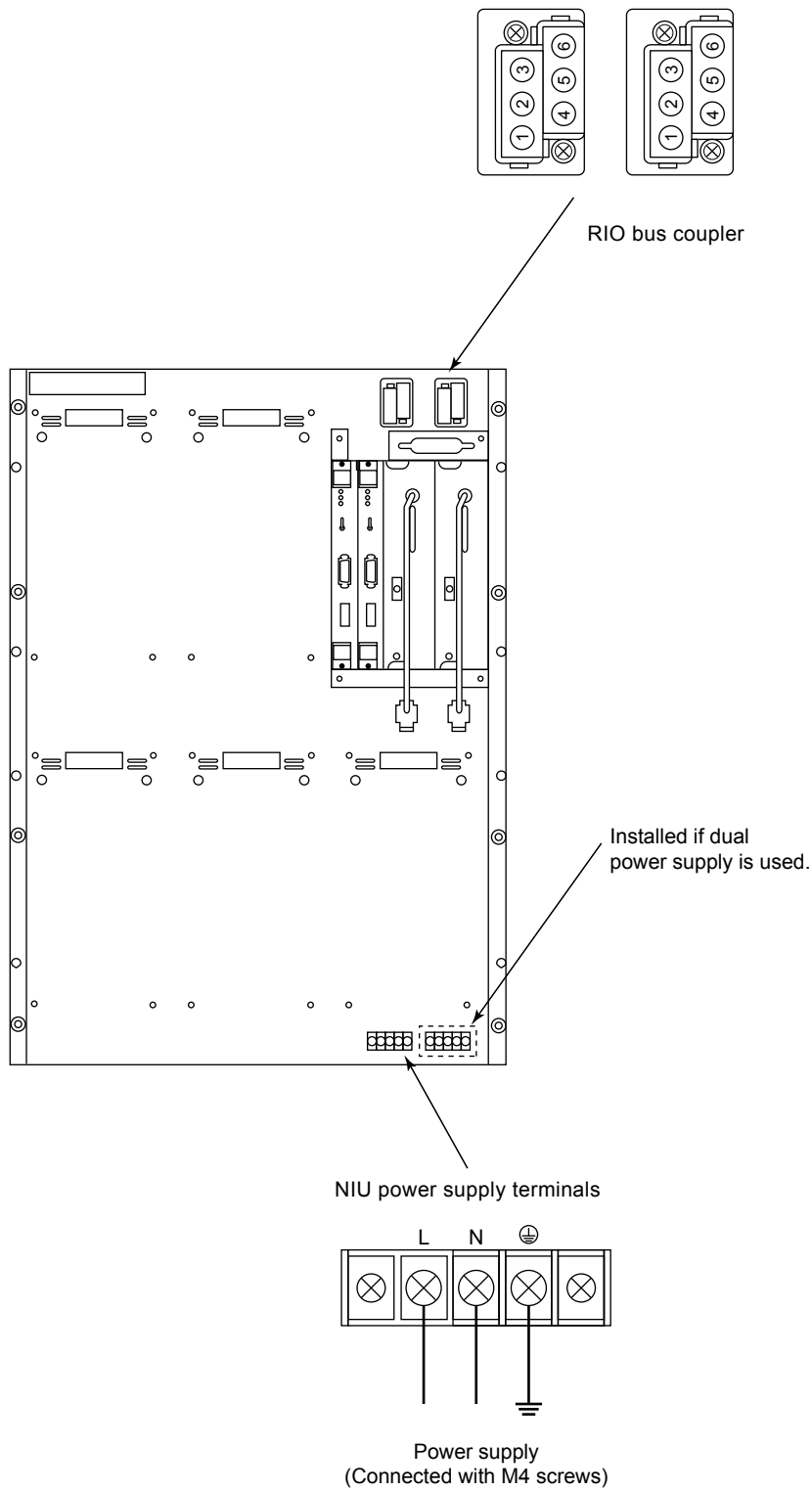

Figure PFCS/PFCD Power Cable Connections

ANS50/AND50 Node Interface Unit (19-inch Rack Mountable Type)



F030414.ai

Figure ANS50/AND50 Cable Connections

Power Wiring When Connecting Dual Power Supply Lines

When installing an AND50 to an ACB21 I/O expansion cabinet, abide by the following:

1. Do not connect the shield wire of either power supply cable to the power distribution board in the ACB21. Cut off the shields at the ends of the insulation for both cables.
2. Connect the conductors of each power supply cable to the L and N terminals on the power distribution board in the ACB21.
3. For power wiring to the AND50 (dual power connection model), connect the L and N terminals on power distribution board to the L and N terminals of the AND50, respectively, as shown in the figure below. Connect the G terminals of the AND50 to the grounding bar of the cabinet.
4. For the grounding of an entire cabinet, connect the grounding bar of the cabinet to the dedicated grounding bus or pole at a grounding resistance of 100 ohms or less.

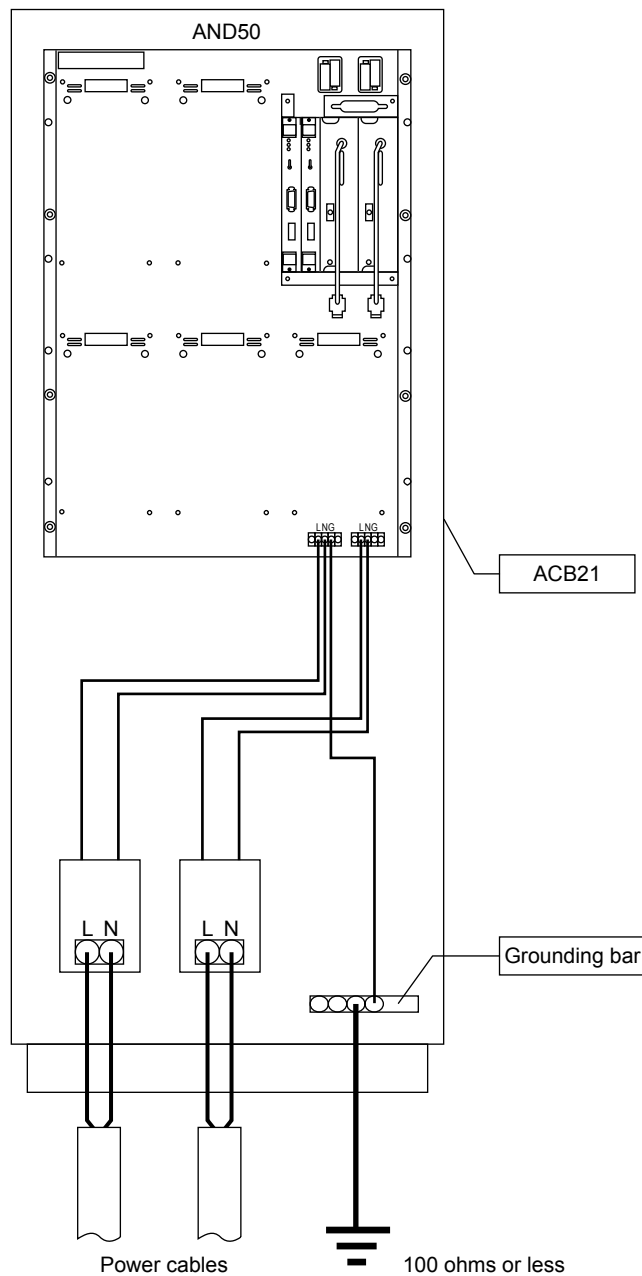

F030419.ai

Figure Power Wiring When Connecting Dual Power Supply Lines

ANB10S/ANB10D ESB Bus Node Unit (19-inch Rack Mountable Type)

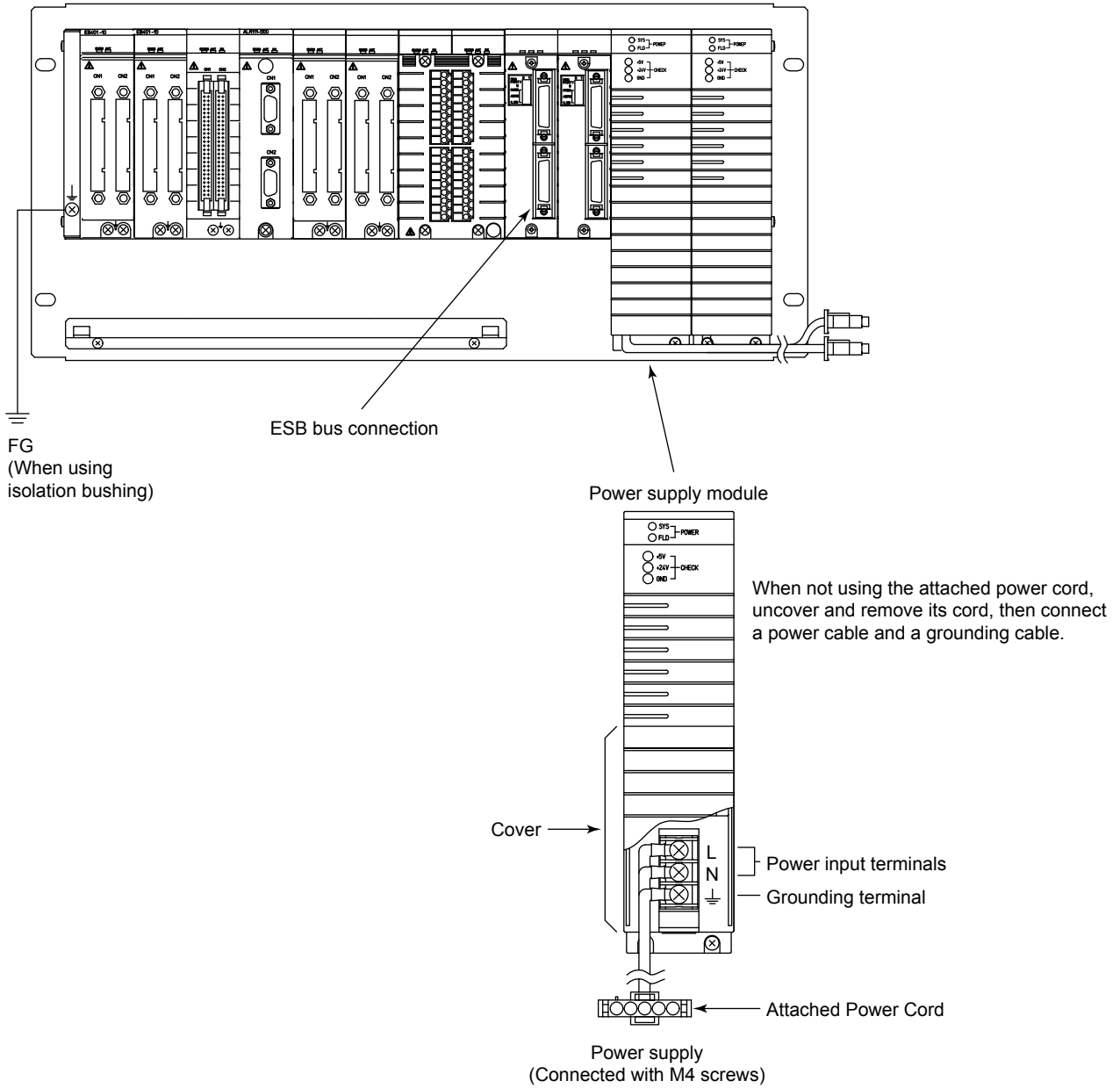

Figure ANB10S/ANB10D Power Cable Connection

F030420.ai

ANR10S/ANR10D ER Bus Node Unit (19-inch Rack Mountable Type)

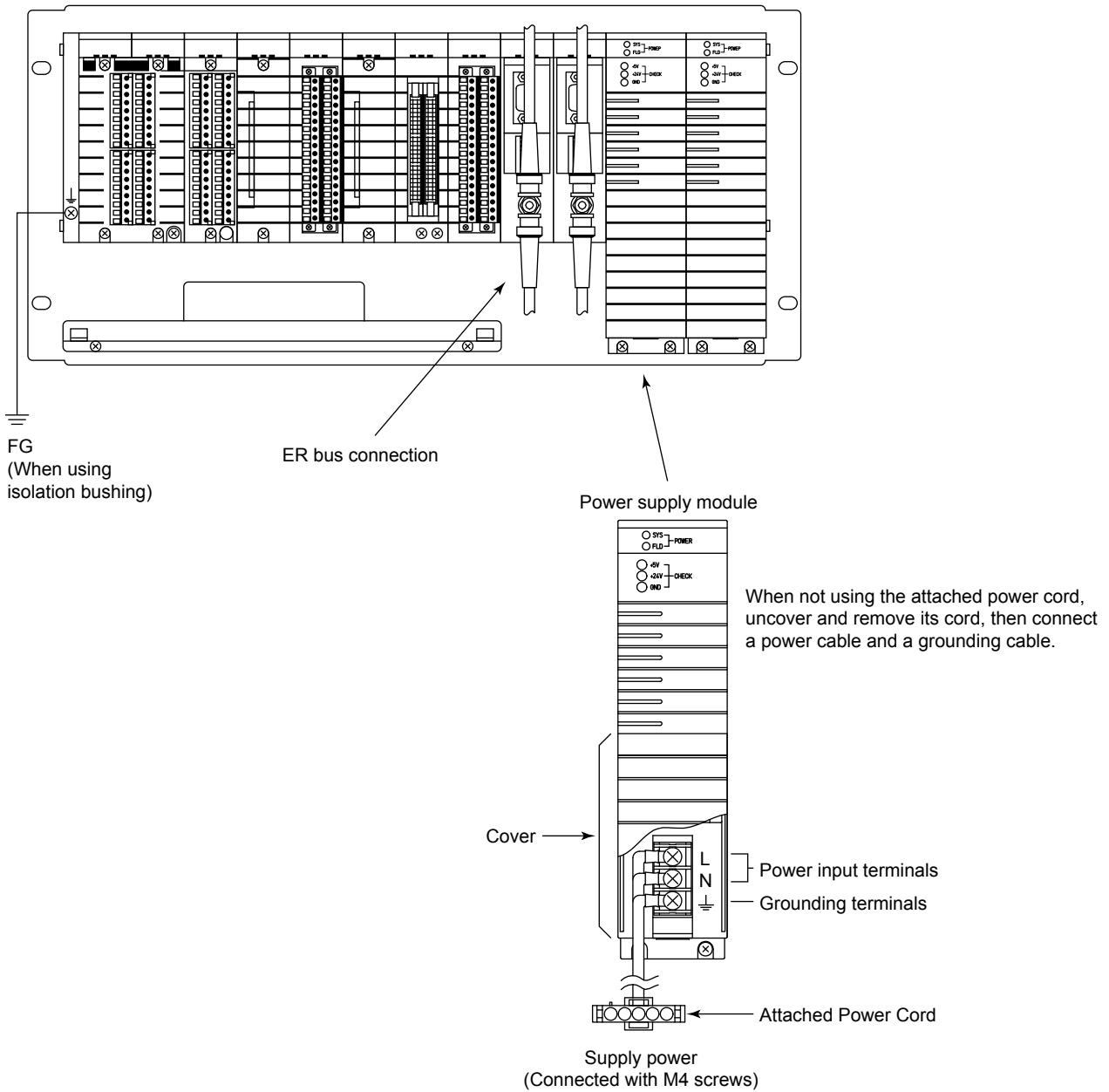
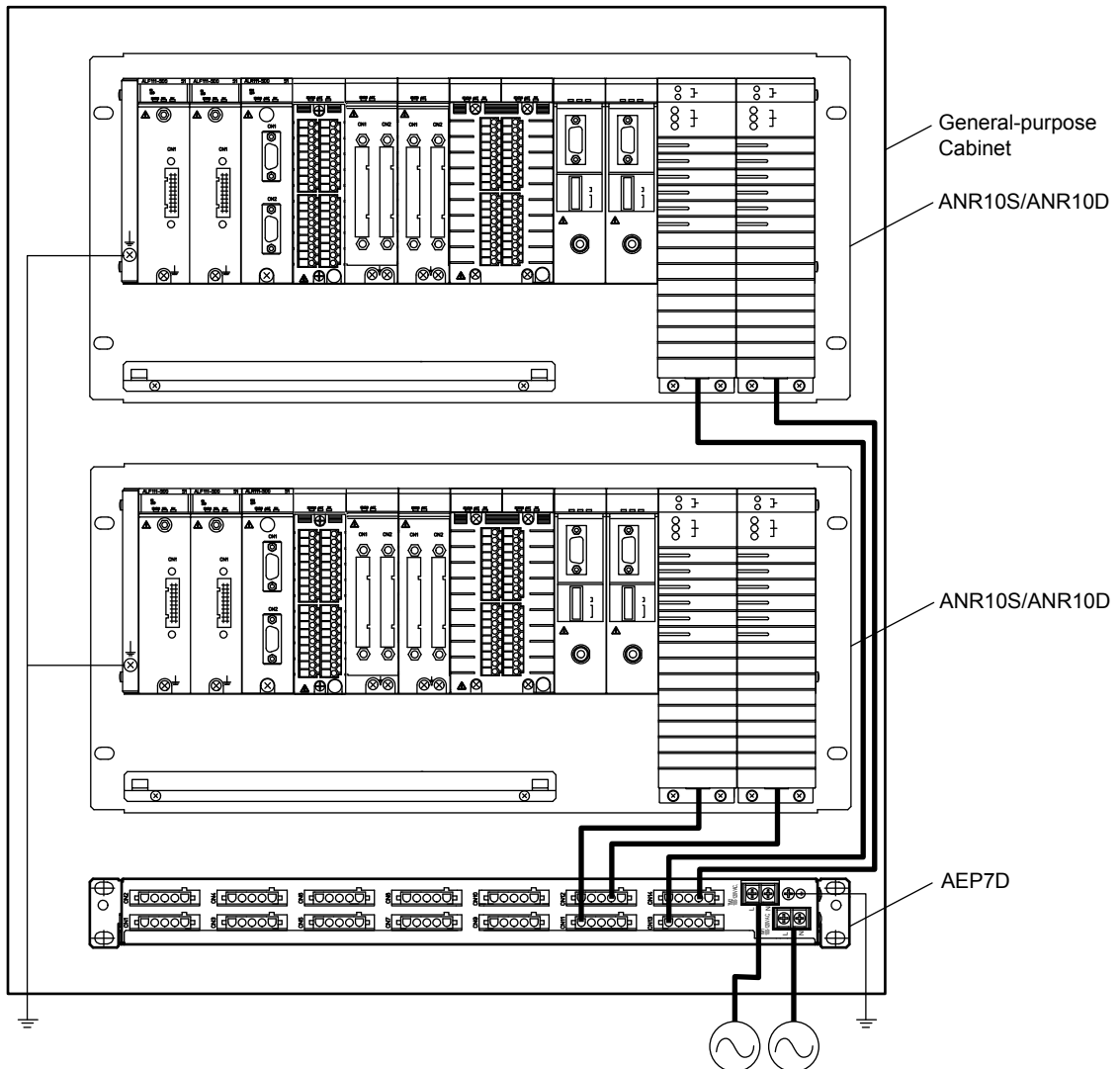

Figure ANR10S/ANR10D Power Cable Connection

F030412.ai

An example of installing an ER Bus Node Unit in a general-purpose cabinet along with an AEP7D Primary Power Supply Bus Unit is shown.



F030422.ai

Figure Example of Installing ANR10S/ANR10D in a General-purpose Cabinet (Dual AC Power Supply Line)

19-inch Rack-mount Devices and Wiring

An example of wiring when AFF50□ or ANB10□ is mounted to a general-purpose cabinet in the following:

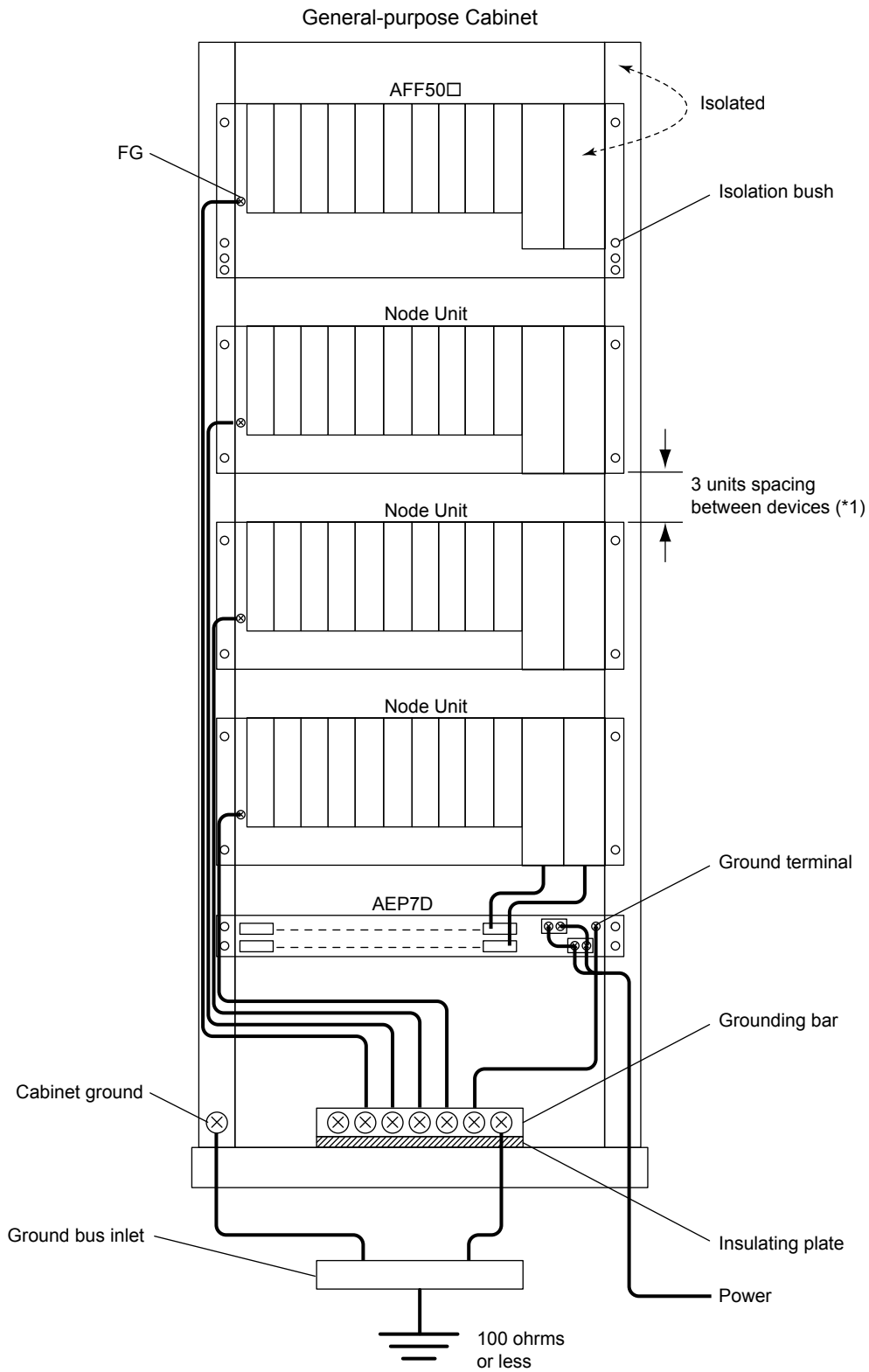

F030423.ai

*1: Keep a space of 3U or more for heat radiation.

Figure 19-inch Rack-mount Devices and Wiring

YNT511S/YNT511D, YNT522S/YNT522D Optical Bus Repeater

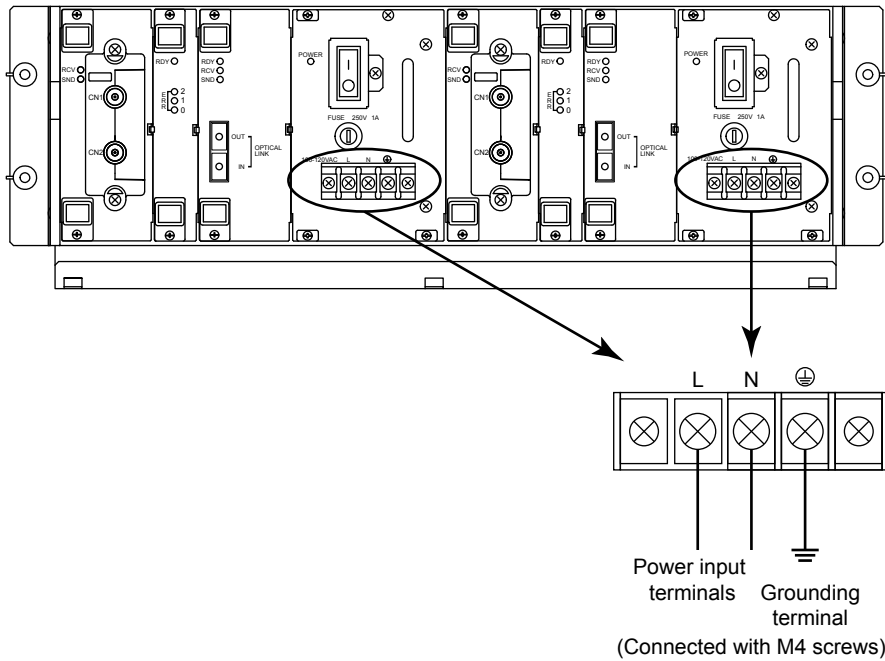

F030406.ai

Figure Optical Bus Repeater Power Cable Connection

YNT512S/YNT512D Bus Repeater

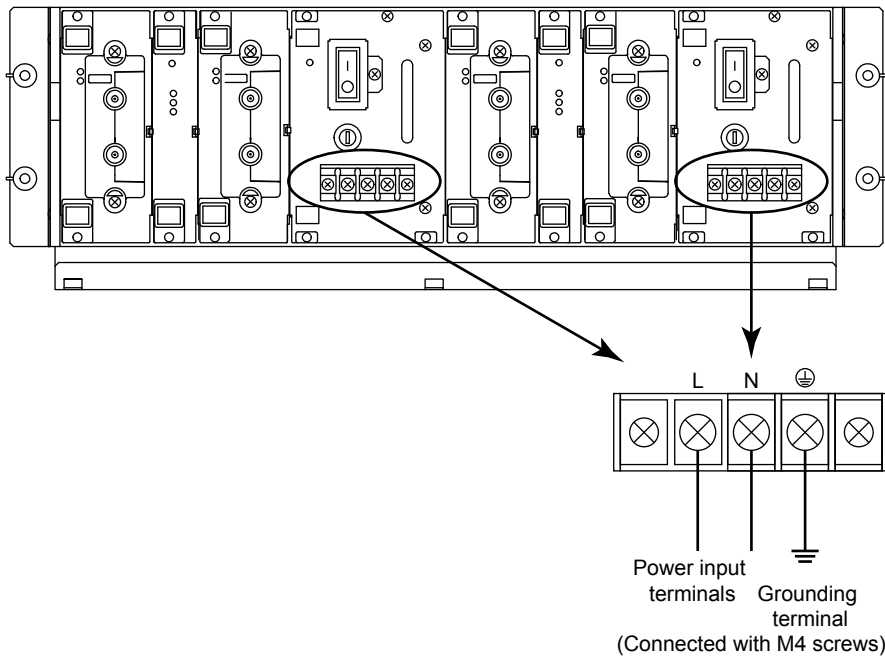

F030407.ai

Figure Bus Repeater Power Cable Connection

ACG10S Communication Gateway Unit

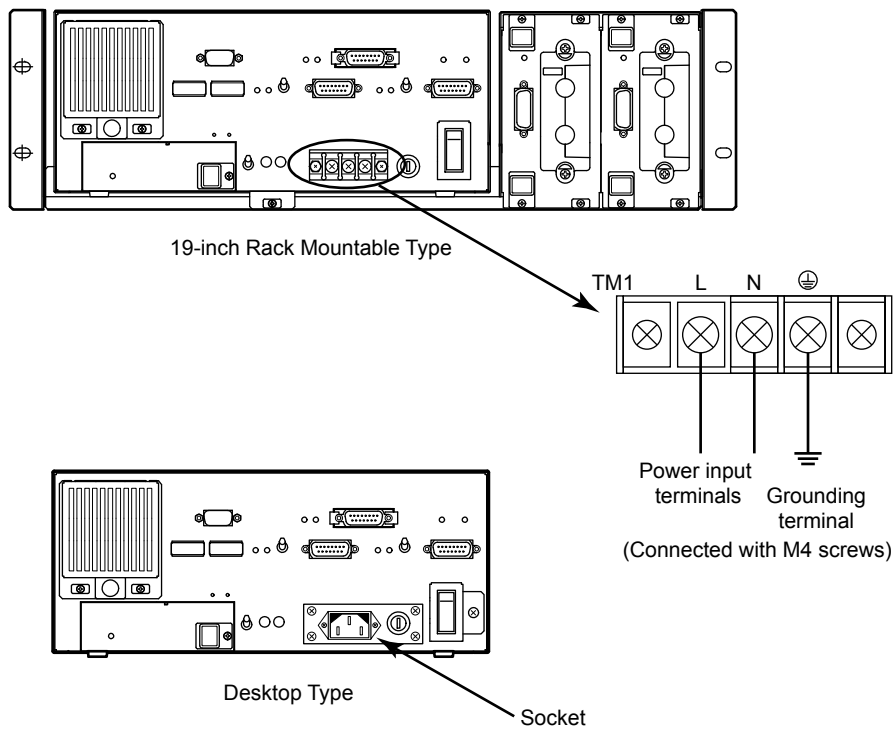

Figure ACG10S Power Cable Connection

F030415.ai

ABC11S/ABC11D Bus Converter

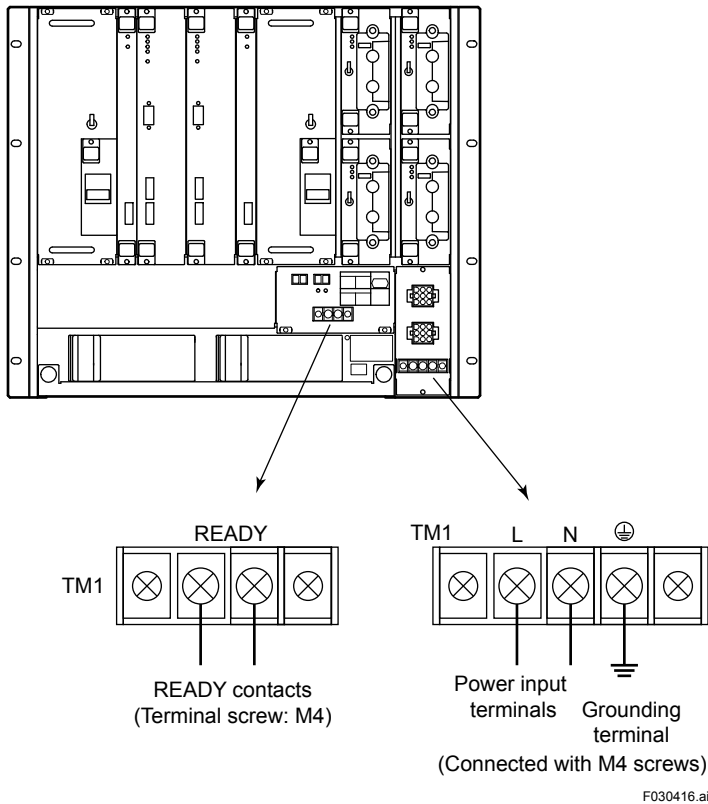

Figure ABC11S/ABC11D Cable Connections



IMPORTANT

If wiring the contact cable to the READY contact output terminals, attach a clamp filter (part No. A1193MN with cable fastener, coming with an ABC11S/ABC11D) supplied with hardware, near the terminals.

This inside diameter of the core is 9 ± 1 mm.

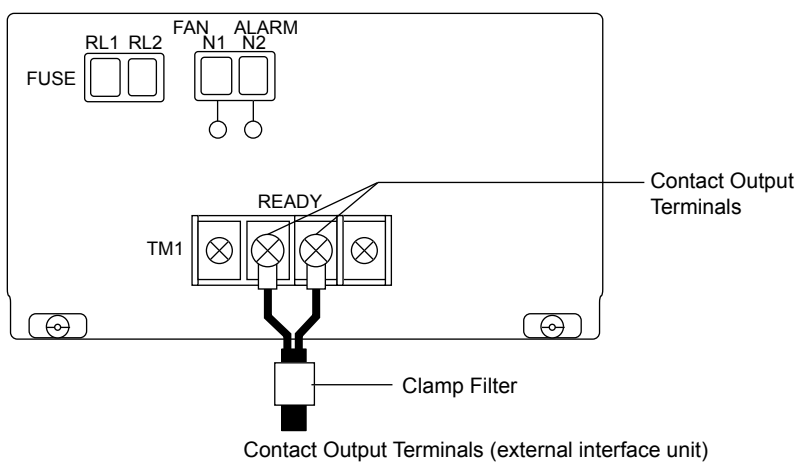

Figure Clamp Filter

YAX101 General-Purpose Desk

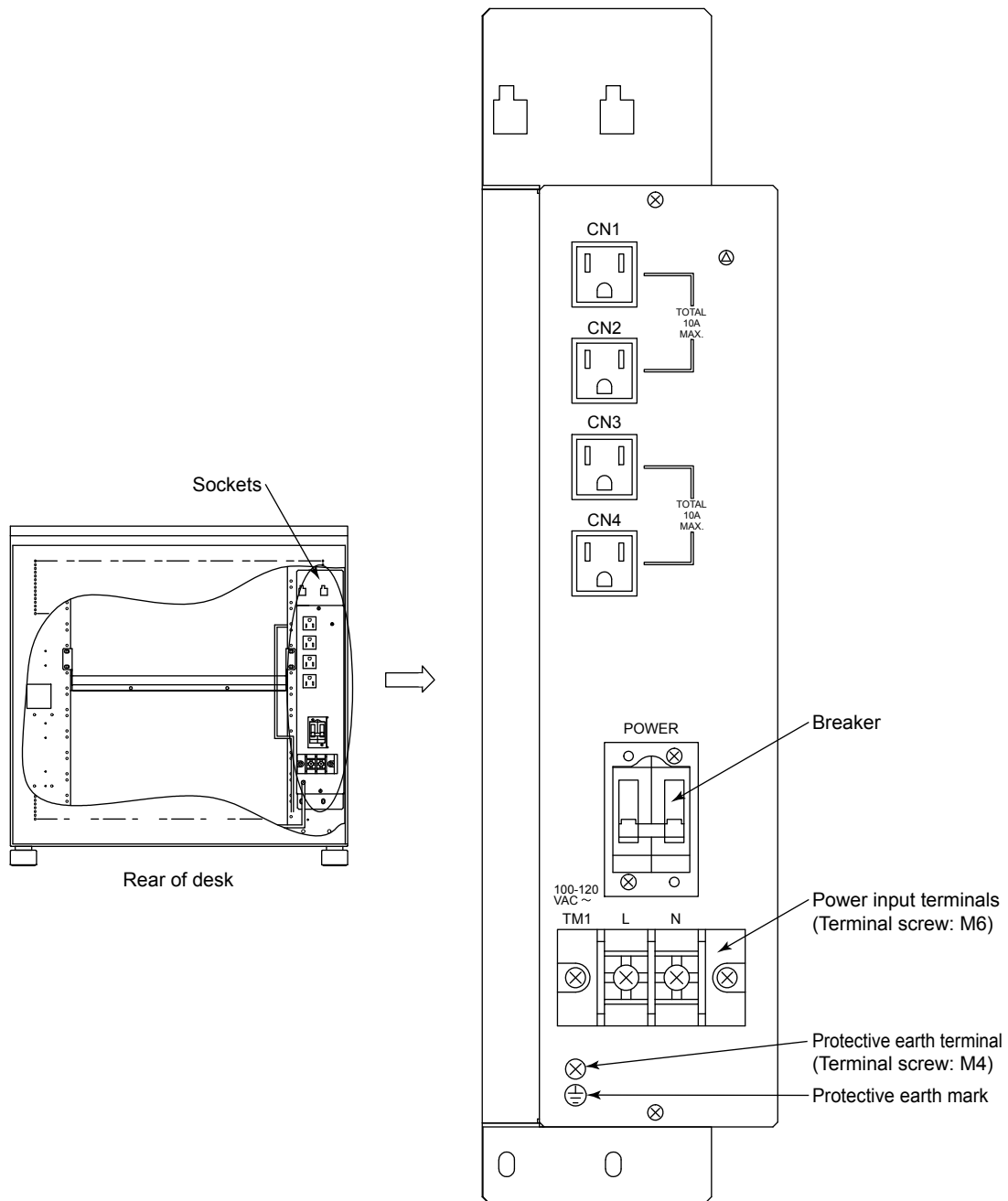

Figure YAX101 Power Cabling

F030408.ai

YAX801 General-Purpose Desk

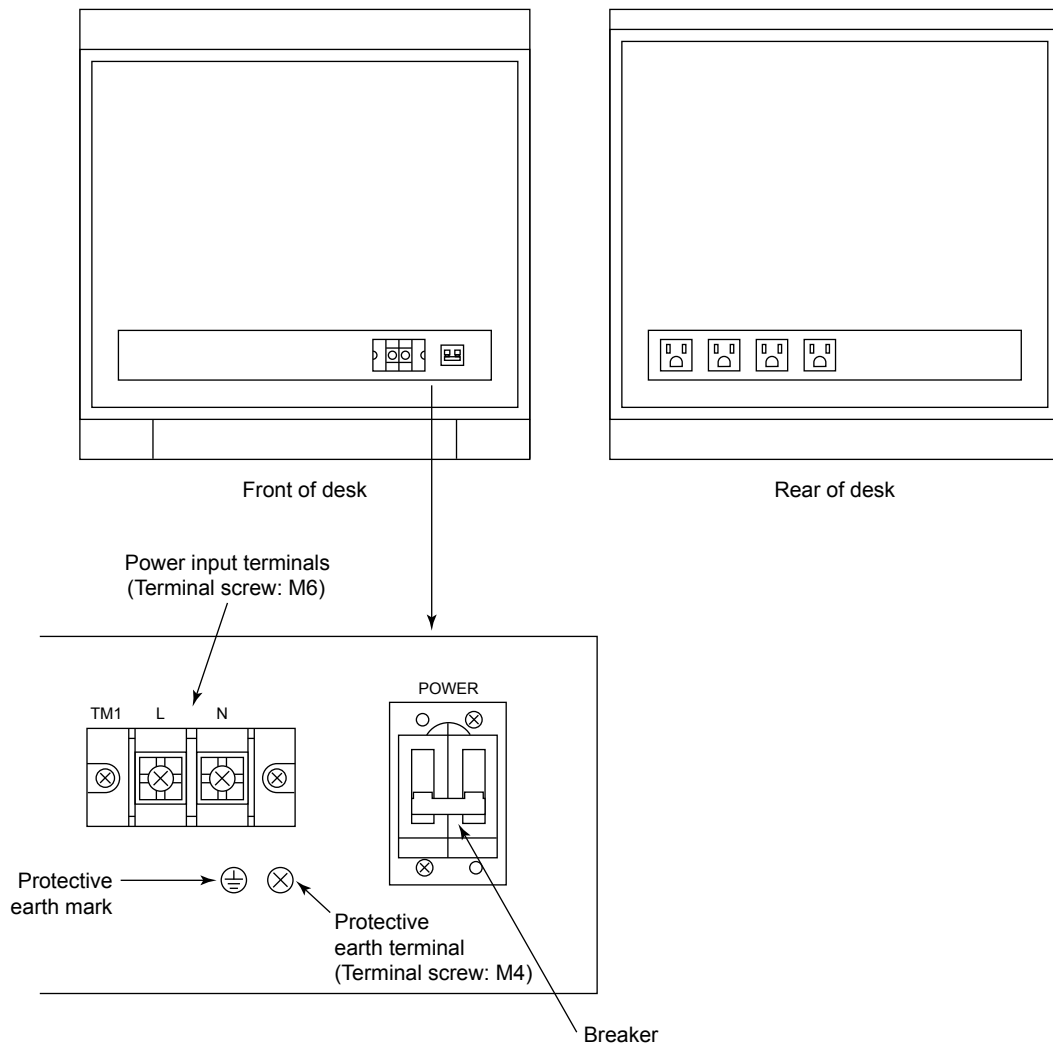

Figure YAX801 Power Cabling

F030413.ai

3.5 Connecting Signal Cable

The terminals or connectors of field control station I/O modules interface I/O signals from the field.

Process I/O Signal Connection

- Power, Control Bus, and signal cables must be separately laid. Avoid laying them in parallel.
- The use of group-shielded twisted-pair cables is recommended for analog signal input specifically in order to prevent induction noise. A twisted-pair cable pitch of 50 mm or less should be used and the shielded cables must be grounded.
- The use of twisted-pair cables is also recommended for digital signals.
- The twisted-pair cable has the following advantages over a solid wire:
 - More flexible for easy curving and cabling in limited spaces.
 - With good contact and durable in using a solderless contact.
- Signal cables must be clamped so that their weight does not affect terminals.
- Use solderless lug or pressure clamp terminal contact when process I/O signals are connected with terminals.

Solderless Lug



IMPORTANT

- The CS 3000 system uses spring terminals for RIO signal and RIO bus connections.
 - Use the solderless contact with an insulation covering.
 - Use the solderless contact and crimp tools of the same make.
 - Use correct-size crimp tools according to cable sizes.
 - When the door is attached or detached for cable connection, be sure to then OFF the power of the main unit before connecting or disconnecting a cable.
-

Pressure Clamp Terminal



IMPORTANT

- The CS 3000 uses a pressure clamp terminal for signal connection of FIO.
 - For cable connection with a sleeve attached, use a sleeve and a clamp tool from the same manufacturer.
 - Use a clamp tool which suits the cable thickness.
 - When the door is attached or detached for cable connection, be sure to then OFF the power of the main unit before connecting or disconnecting a cable.
-

Signal Cable Termination

Solderless Lug

- Cable termination

Use solderless lugs for all the RIO I/O signals that are wired by terminal connection.

- Solderless lug specifications

The specifications of the solderless lug to use are determined by the nominal cross sectional area of the power cable for which the lug is to be used, the lug screw, dimensions and so on.

Table Solderless Lug Dimensions

Nominal cross sectional area (mm ²)	Screw used (mm)	Hole diameter (mm)	Lug outside diameter (mm)	Lug length (mm)	Insulation covering inside diameter (mm)	Dimension "C" (mm)
1.25	4	4.3 or more	8.2 or less	Approx.21	3.6 or more	7.0 or more
2.0	4	4.3 or more	8.7 or less	Approx.21	4.3 or more	7.1 or more
1.25	3.5	3.7 or more	6.8 or less	Approx.21	3.6 or more	4.0 or more
2.0	3.5	3.7 or more	6.8 or less	Approx.21	3.6 or more	4.0 or more

AMP: Japan AMP Co., Ltd.

JST: JST Co., Ltd. (Insulators 0.8 mm² or more in size are optionally available.)



IMPORTANT

- For CENTUM CS 3000, spring lugs are used for connecting signals for RIO and for connecting the RIO bus.
- Always use solderless lugs with insulated covering.
- Always use solderless lugs and crimp-on tool manufactured by the same manufacturer.
- The crimp-on tool must be matched to the wire thickness.

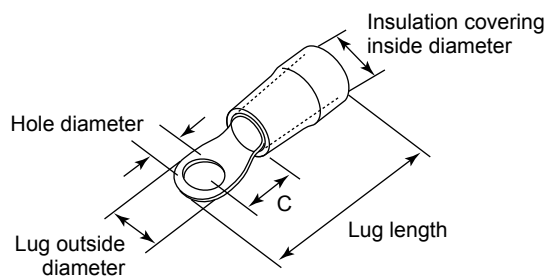

F030522.ai

Figure Solderless Lug

Pressure Clamp Terminal (for Pressure Clamp Terminal Block)

- Terminal processing
When connecting the process I/O signal to the pressure clamp terminal of FIO, strip the cable coating (without a sleeve) or attach a sleeve to the cable. The following shows the length of the coating stripped for cases when a sleeve is not used and when it is used.

Table Without a sleeve

Cable thickness (mm ²)	Length of coating stripped (mm)	Remarks
0.5 to 2 (AWG20 to 14)	11	Other than below
1.25 to 2 (AWG16 to 14)	13	When connecting to ATC4S, ATC5S

Table With a sleeve

Cable thickness (mm ²)	When using a sleeve with an isolation cover				When using a sleeve without an isolation cover		
	Length of coating stripped (mm)	Sleeve size		Model No. of Weidmuller	Length of coating stripped (mm)	Sleeve size	
		Total length (mm)	Contact section length (mm)			Total length (mm)	Model No. of Weidmuller
0.5	11	16	10	H0.5/16	11	10	H0.5/10
0.75	11	16	10	H0.75/16	11	10	H0.75/10
1	11	16	10	H1/16	11	10	H1/10
1.25 to 1.5	11	16	10	H1.5/16	11	10	H1.5/10
1.25 to 1.5	13	18	12	H1.5/18D(*1)	13	12	H1.5/12(*1)

*1: When connecting to ATC4S, ATC5S

Pressure Clamp Terminal (for ARS□□M)

For both signal line and power line of the Solid State Relay Board ARS□□M, pressure clamp terminals are used.

- Terminal processing
When connecting the signal and power line to the pressure clamp terminal, strip the cable coating (without a sleeve) or attach a sleeve to the cable. The following shows the length of the coating stripped for cases when a sleeve is not used and when it is used.

Table Terminal treatment for pressure clamp terminal signal line

	Cable thickness (mm ²)	Length of coating stripped (mm)	Inserting length of sleeve (mm)
Without sleeve	0.5 to 2 (AWG20 to 14)	8	–
With sleeve	0.5 to 2 (AWG20 to 14)	8	8

Table Terminal treatment for pressure clamp terminal power line

	Cable thickness (mm ²)	Length of coating stripped (mm)	Inserting length of sleeve (mm)
Without sleeve	0.5 to 2 (AWG20 to 14)	9	–
With sleeve	0.5 to 1.5 (AWG20 to 16)	9	8

Connecting Signal Cables to Terminals (for FIO)

Connecting to Pressure-clamp Terminal

1. Loosen the cable connecting terminal screw.
2. Strip the cable coating (without a sleeve) or attach a sleeve to the cable, then insert the tip of the cable into the connecting section of the pressure clamp terminal.
3. Fasten the screw using the special tool (a screw driver conforming to the DIC 5264B standard with a tip width of 0.6 mm and a shaft diameter of 3.5 mm) with a fastening torque of 0.5 N•m.

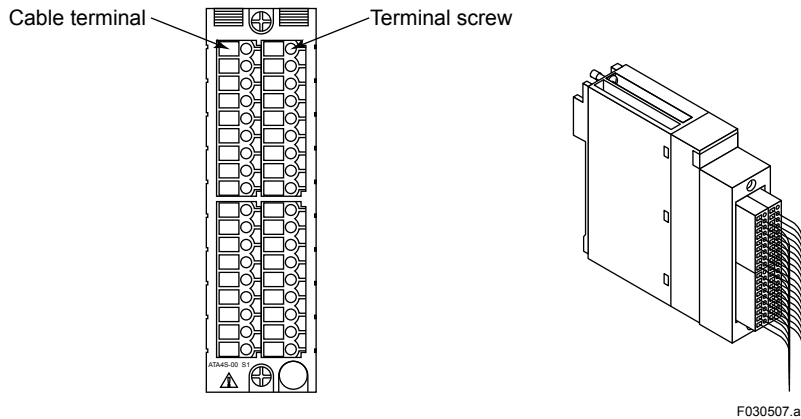

Figure Connecting Signal Cable to Terminal (for FIO)



IMPORTANT

Do not use non-standard signal cable or sleeve; using them could cause improper connection. Be sure to remove the cable sheath just as much as specified, fit the sleeve, and clamp the cable firmly to the terminal.

Routing Signal Cables

Areas for Signal Cables from Field

Signal cables from the field enter the FCS at the bottom and connect to individual node units in the routes shown in Figure below.

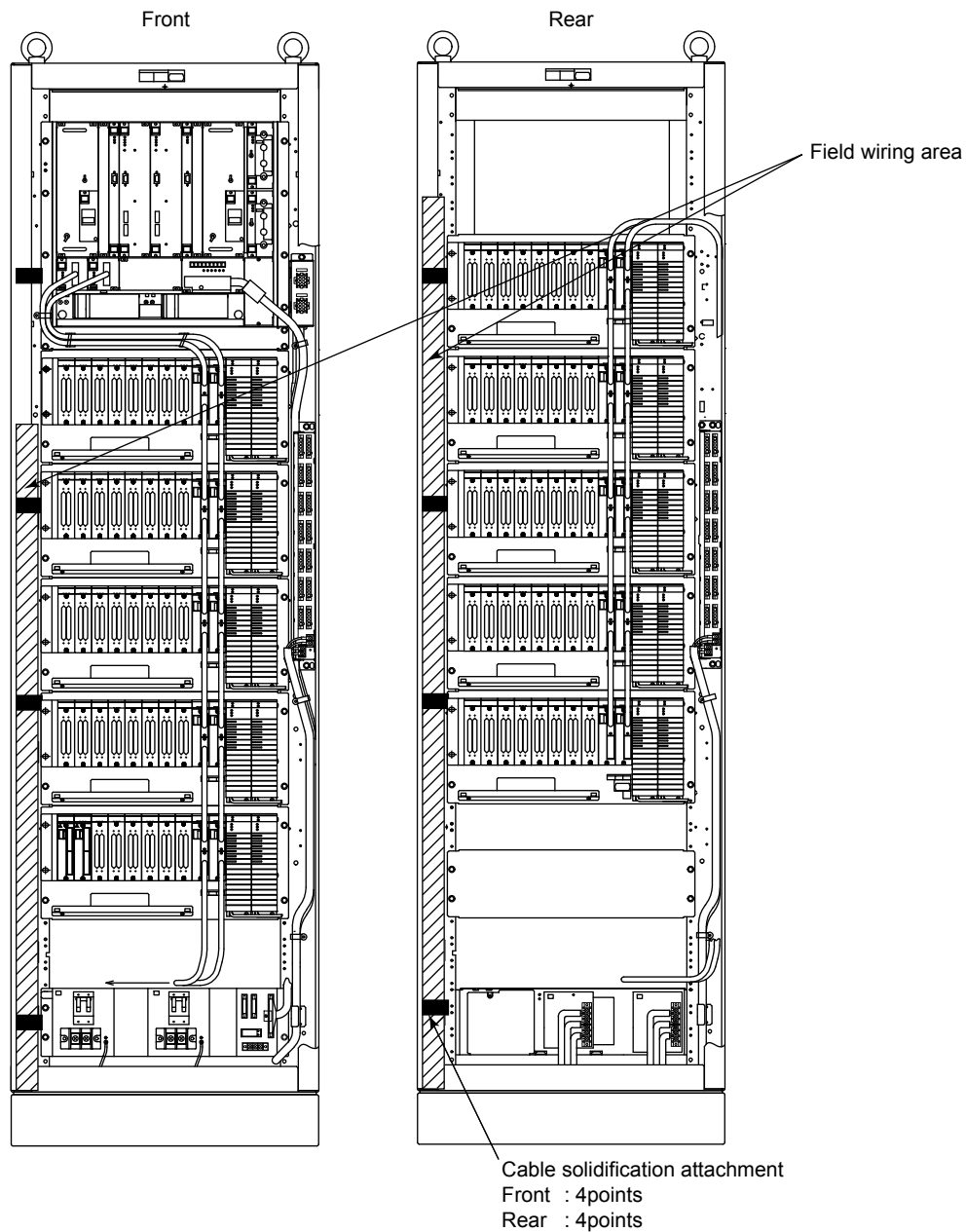

F030517.ai

Figure Areas for Signal Cables from Field

FIO Node Unit Wiring in FCU with Cabinet

The figure shows a dual-redundant ESB bus example.

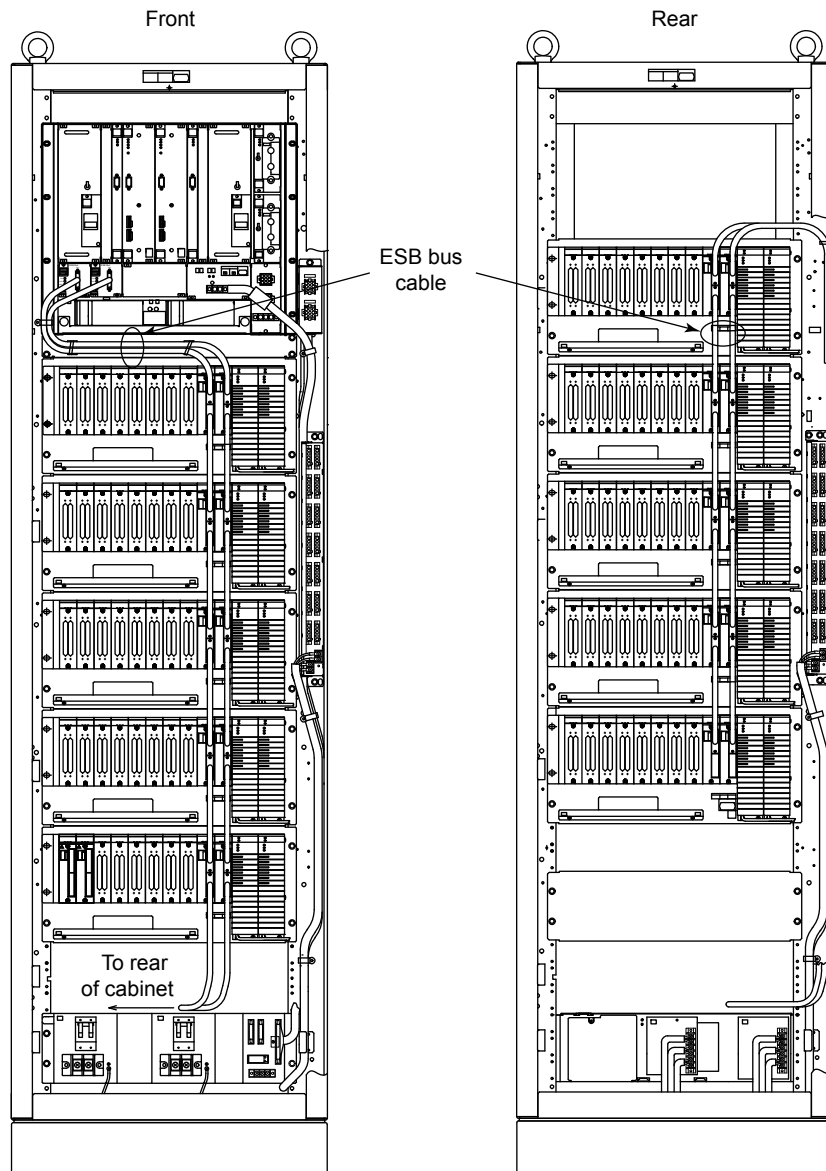

F030518.ai

Figure FIO Node Unit Wiring in FCU with Cabinet

FIO Node Unit Wiring in I/O Expansion Cabinet

The figure shows a dual-redundant ESB bus example, the ESB bus node units installed in the front of the cabinet and the terminal boards in the rear.

Avoid using ESB bus cable with other cables and also avoid wiring its cable in parallel with others.

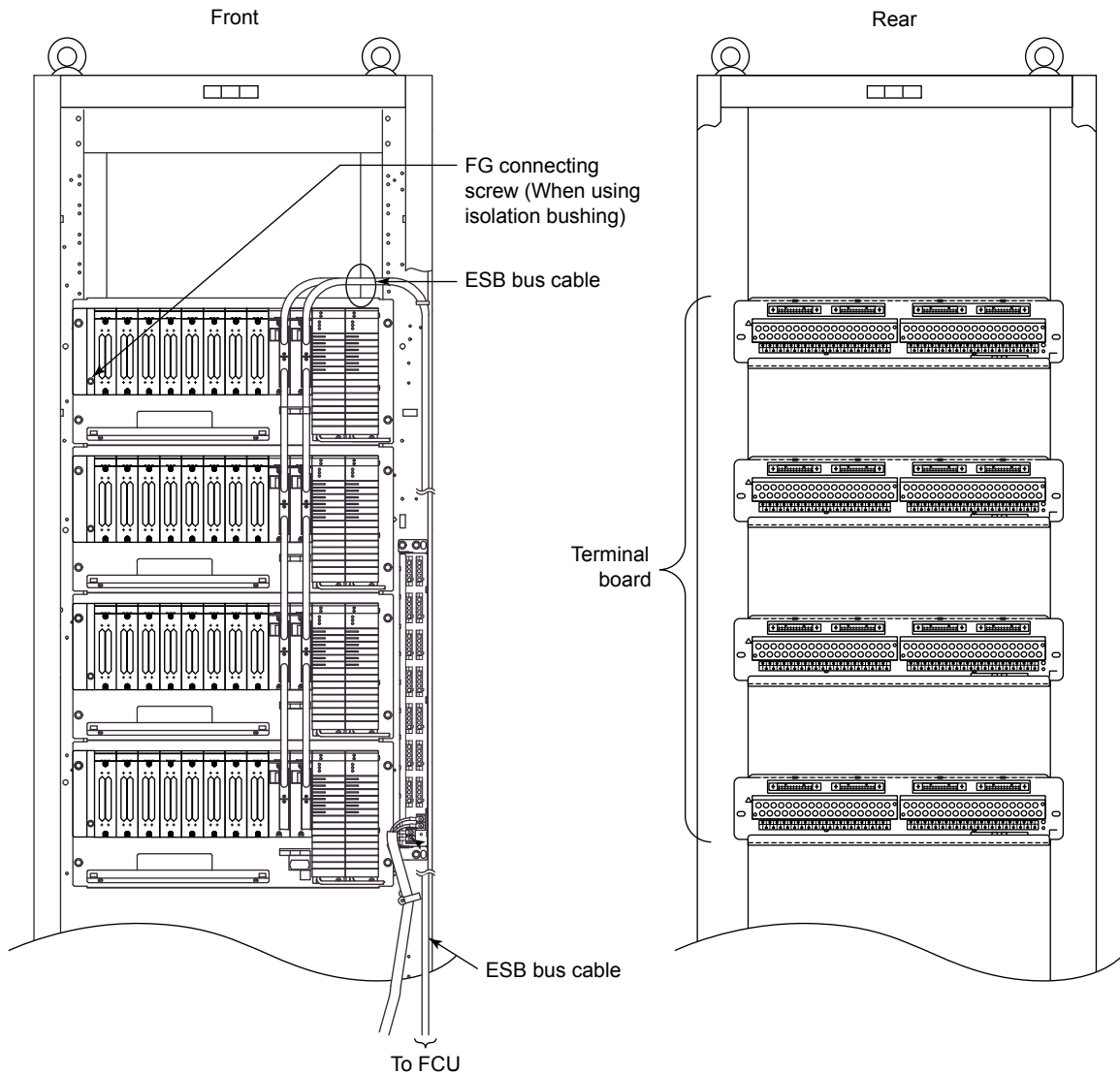

Figure FIO Node Unit Wiring in I/O Expansion Cabinet

F030519.ai

AFF50S/AFF50D, ANR10S/ANR10D Wiring



IMPORTANT

To reserve the ventilation for I/O module, the signal cable should not exceed the separator at the center of cable tray.

The following shows a dual-redundant ER bus example.

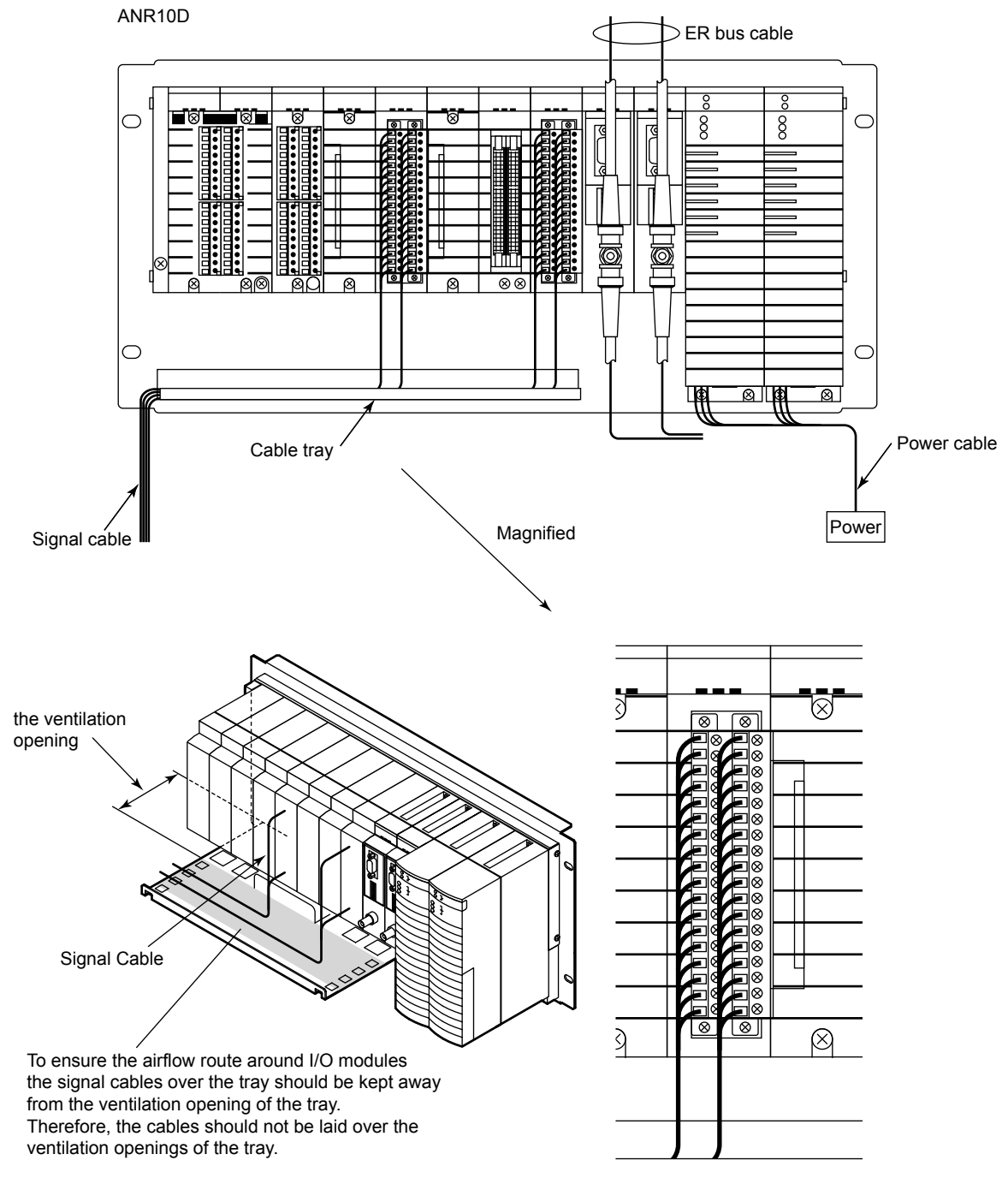

F030516.ai

Figure ANR10D Wiring

FIO Signal Cabling



IMPORTANT

The signal cable for the top node unit must be wired at the innermost part in the field control area as the figure shows.

When fixing cables to a clamp, allow enough space so that the cards can be maintained.
Bind the bottom cables to the clamp bar on the channel base.

Push in the signal cables for the top node unit as far as they will go.

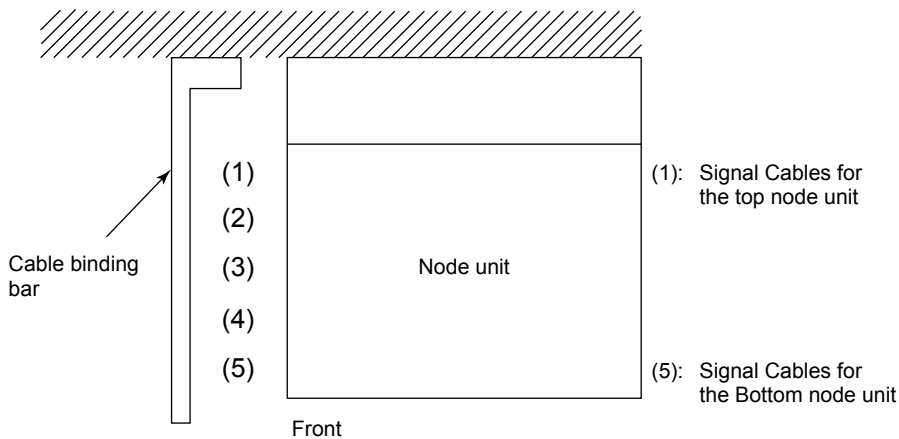

F030514.ai

Figure Signal Cabling

FIO with KS Cable Interface Adapter Cabling

Make a blunt curb for wiring when the dedicated cable is connected to FIO.

Lay the cables in front side of a separator on cable tray.

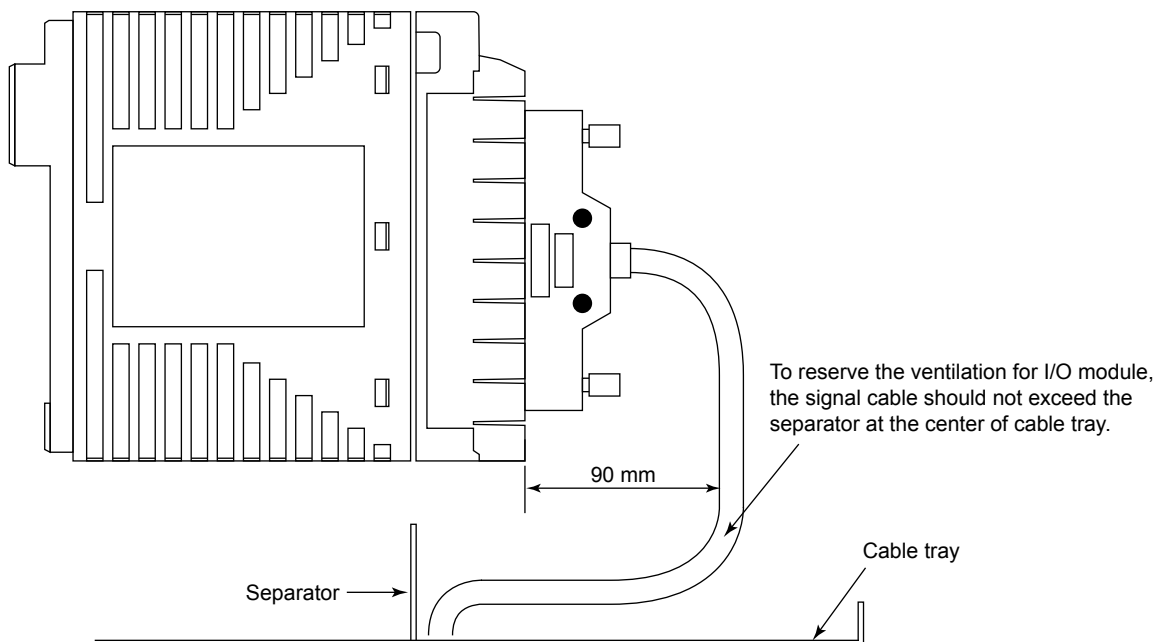

F030515.ai

Figure FIO with KS Cable Interface Adapter Cabling

Connecting Signal Cables to Terminals (for RIO)

1. Open the terminal board cover.
2. Loosen the terminal screws.
3. Insert the tip of the cable's solderless contact between the screw and the spring retainer, and press the retainer to make a gap of about 2 mm between them.
4. Insert the solderless contact further in the gap until the screw enters in the hole of the solderless contact.
5. Tighten the terminal screw.
6. Close the terminal board cover.

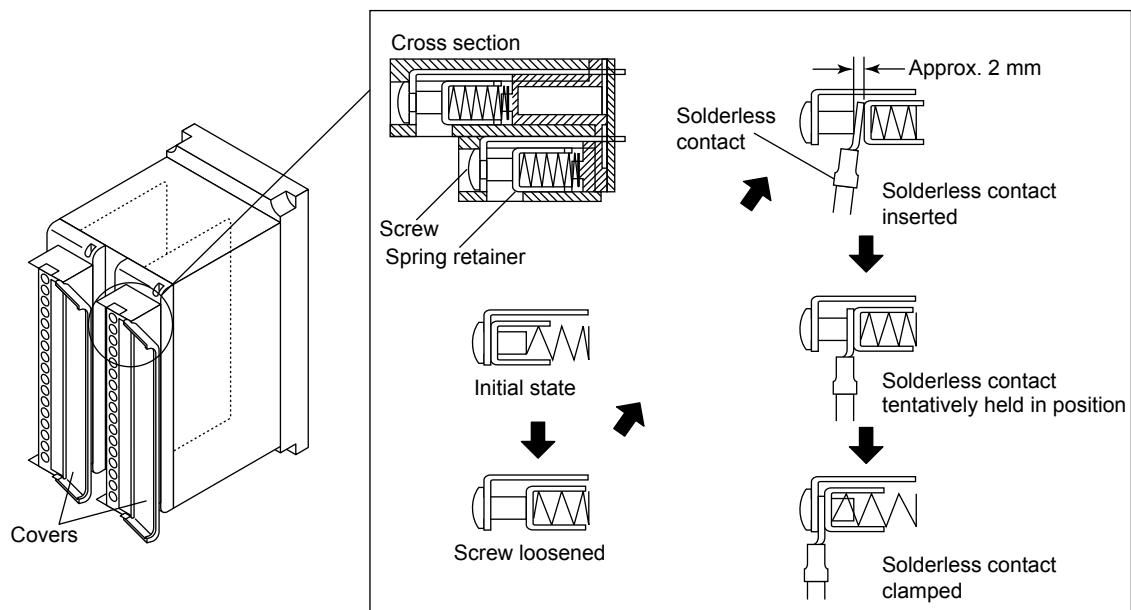

F030501.ai

Figure Connecting Signal Cables to Terminals (Example: multiplexer module)



IMPORTANT

- When connecting solderless lug, be sure to clamp its ring only.
- Using non-standard solderless lug may crush its sleeve, causing a connection failure.

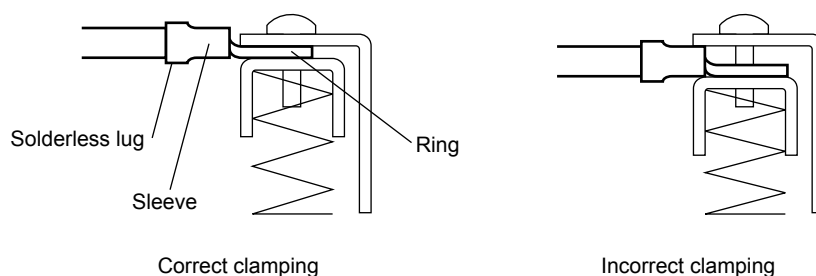

F030502.ai

Figure Connect Clamping of Solderless Lug

Field Cable Areas

Signal cables from the field enter the FCS at the bottom and connect to individual I/O modules in the routes shown in Figure below.

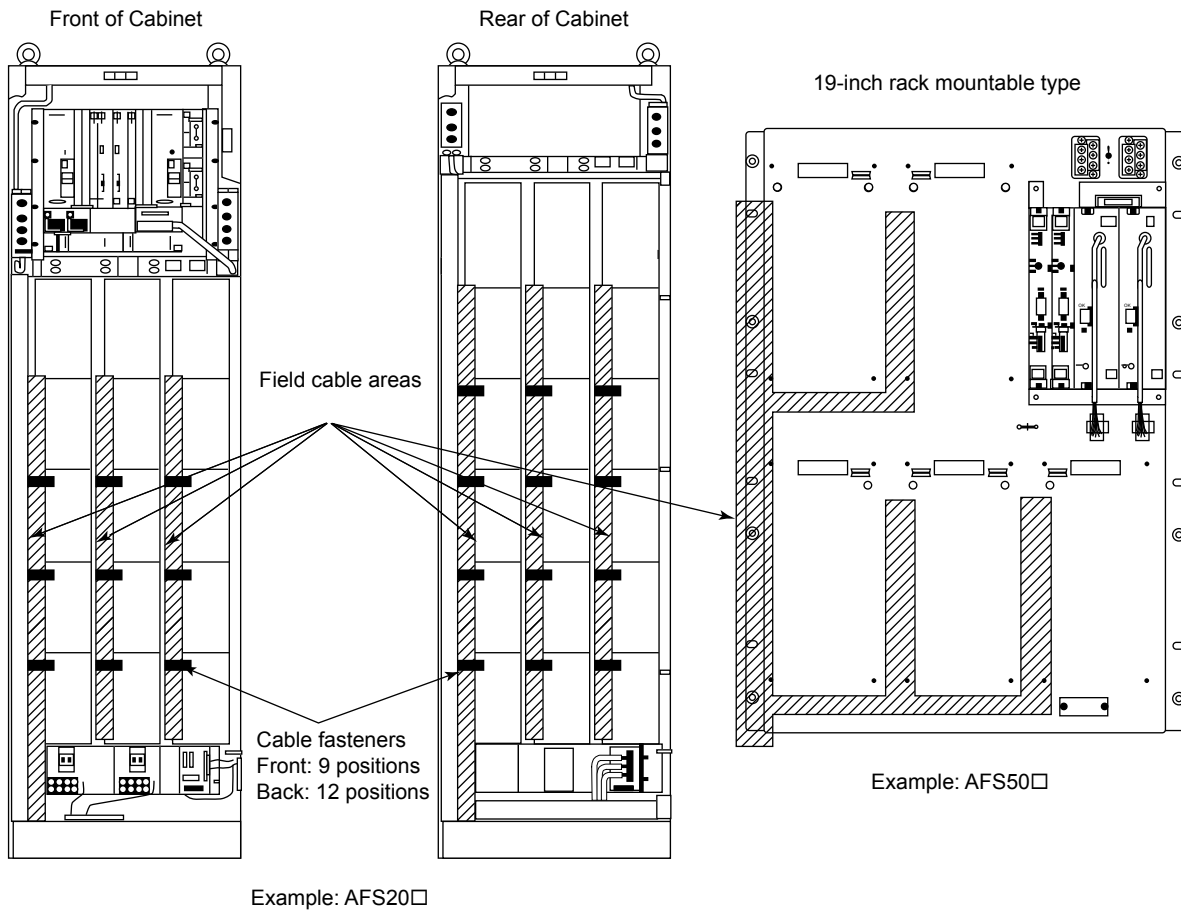

Figure Areas for Signal Cables from Field

F030508.ai

Routing Signal Cables

The route of signal cables for field-to-I/O module connections is shown below.

RIO Node Wiring in FCU Cabinet

The figure shows a dual-redundant RIO bus example.

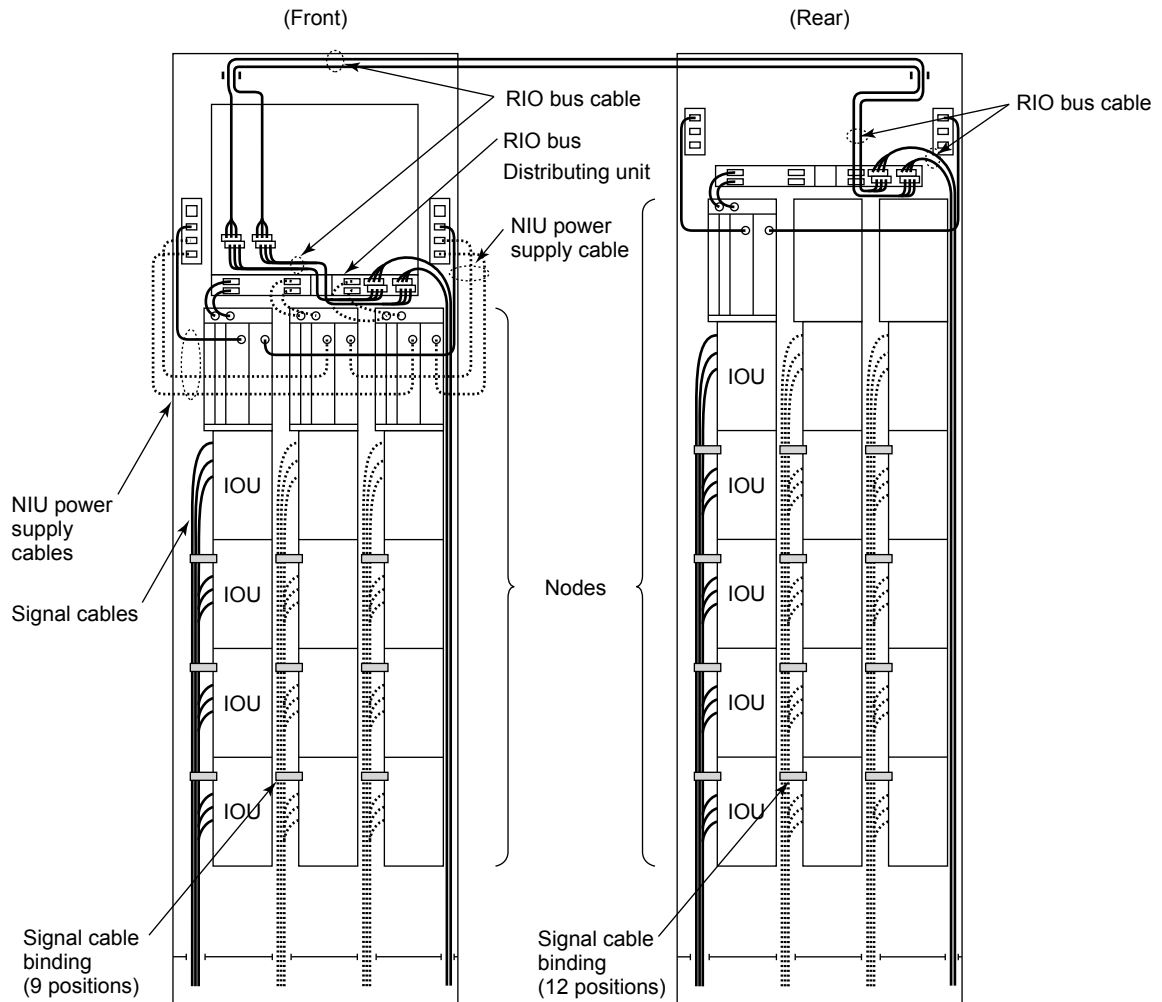

F030509.ai

Figure RIO Node Wiring in FCU with Cabinet

RIO Node Wiring in I/O Expansion Cabinet

The figure shows a dual-redundant RIO bus example.

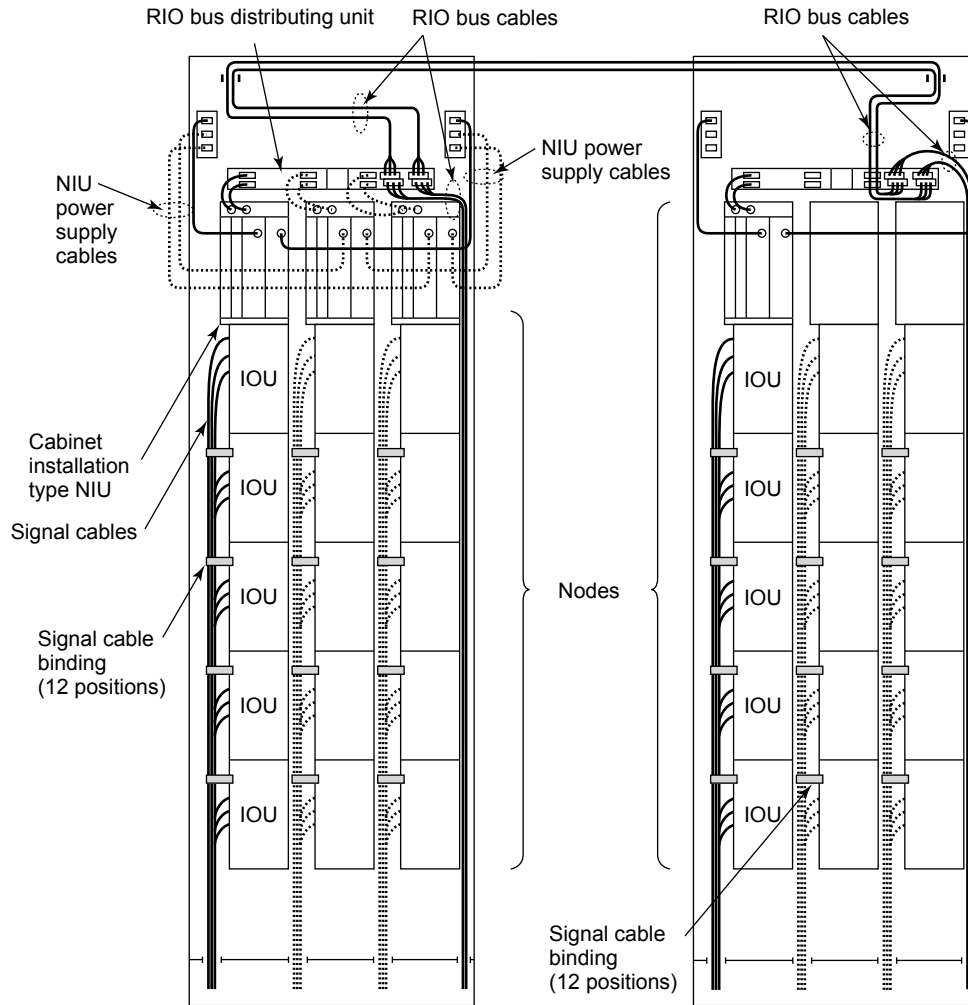

F030511.ai

Figure RIO Node Wiring in I/O Expansion Cabinet

Wiring of ANS50/AND50 19-inch Rack Mountable Type Node

The following shows a dual-redundant RIO bus example.

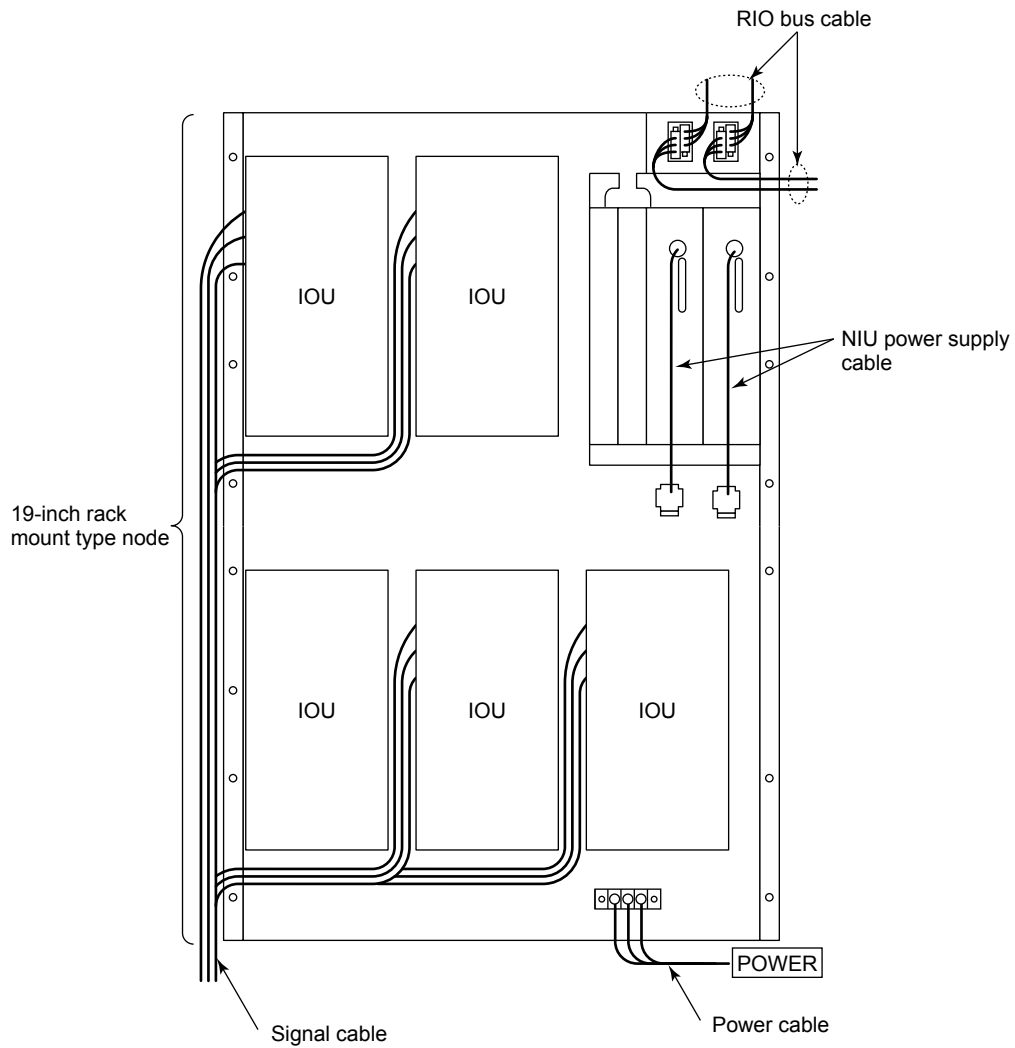

F030513.ai

Figure Wiring of 19-inch Rack Mountable Type Node (with I/O expansion rack)

Wiring of PFCS/PFCD

The following shows a dual-redundant control bus example.

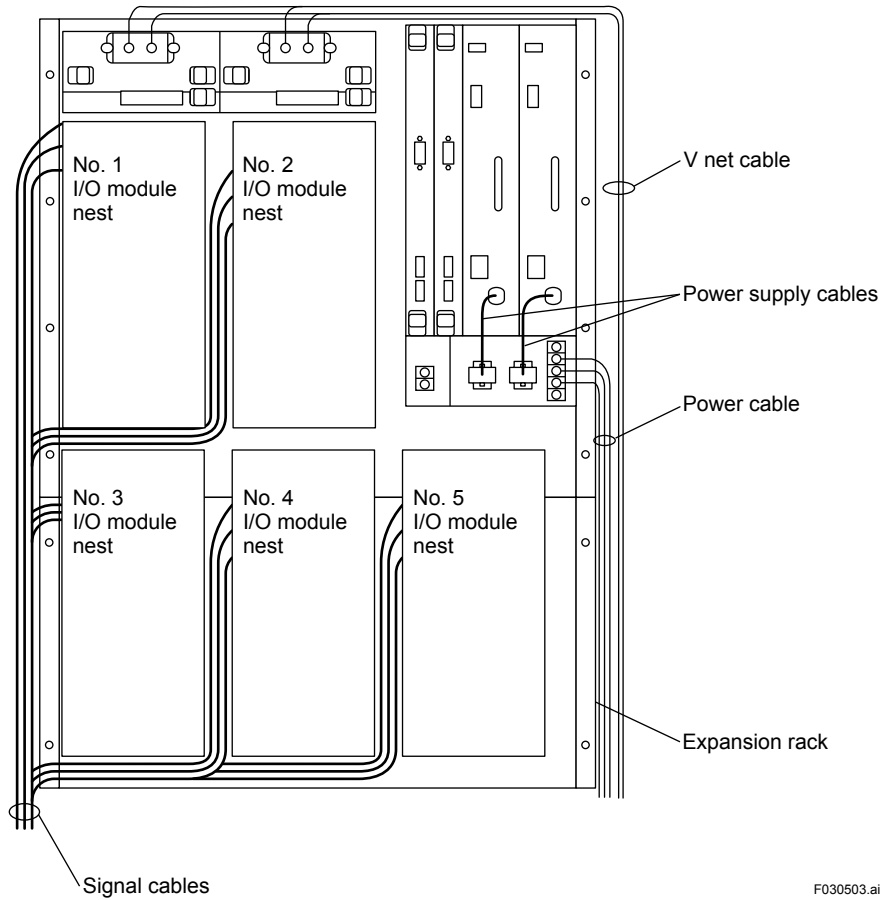

Figure PFCS/PFCD Signal Cable Route

F030503.ai

RIO bus Cabling



IMPORTANT

The signal cable for the top IOU must be wired at the innermost part in the field control area as the figure shows.

When fixing cables to a clamp, allow enough space so that the cards can be maintained. Bind the bottom cables to the clamp bar on the channel base.

Push in the signal cables for the top IOU as far as they will go.

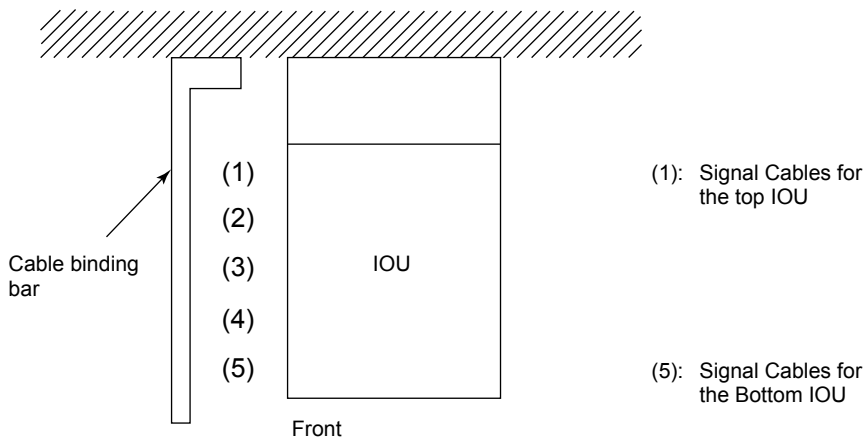

F030510.ai

Figure Cabling

Connector Type IOU Cabling

How to connect cables of the lowest IOU (connector type)

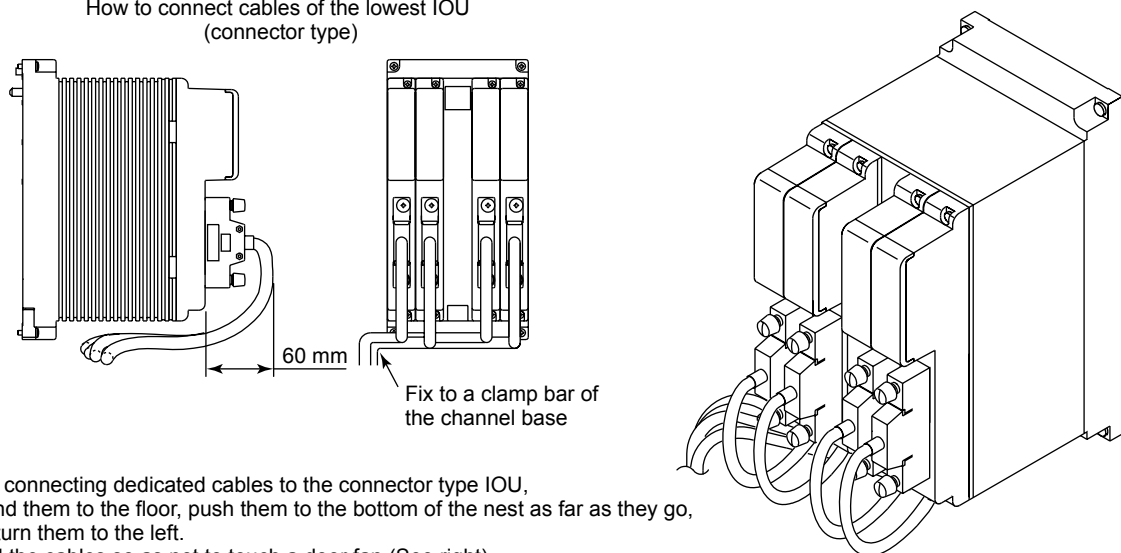

After connecting dedicated cables to the connector type IOU, extend them to the floor, push them to the bottom of the nest as far as they go, and turn them to the left. Bend the cables so as not to touch a door fan (See right). When removing or inserting cards, make sure to bend cables as described herein.

F030512.ai

Figure Connector Type IOU Cabling

Wiring Console Type HIS

When connecting V net cables to a console HIS, lead the cables through the right cable hole. Lead other signal cables through the left cable hole so as to separate them from the V net cables.

Wiring of Console Type HIS (LPCKIT)

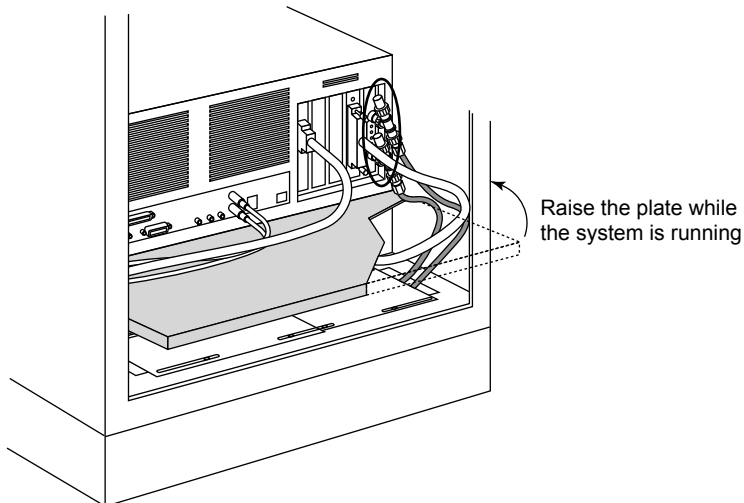

Figure Wiring of Console Type HIS (LPCKIT)

F030521.ai

Wiring of Console Type HIS (YPCKIT)

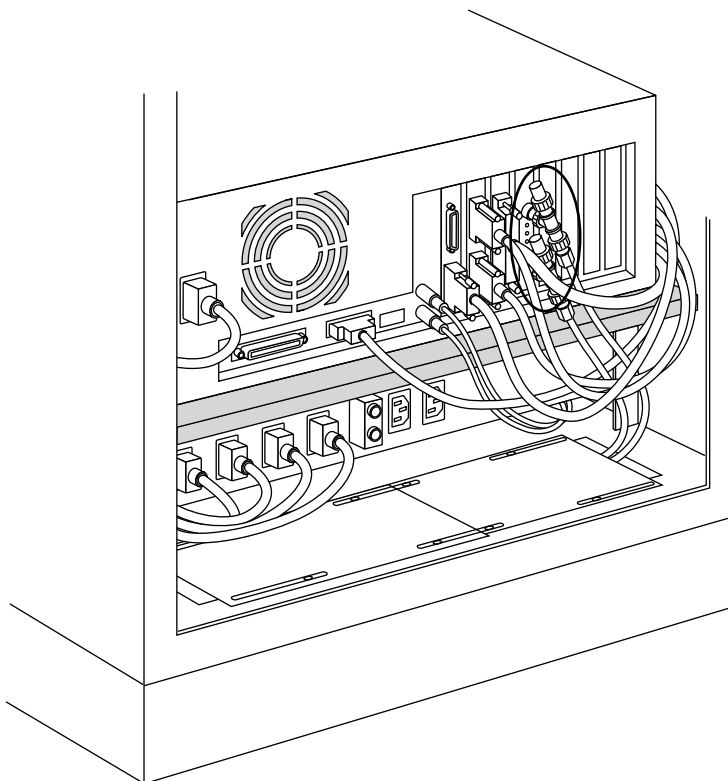
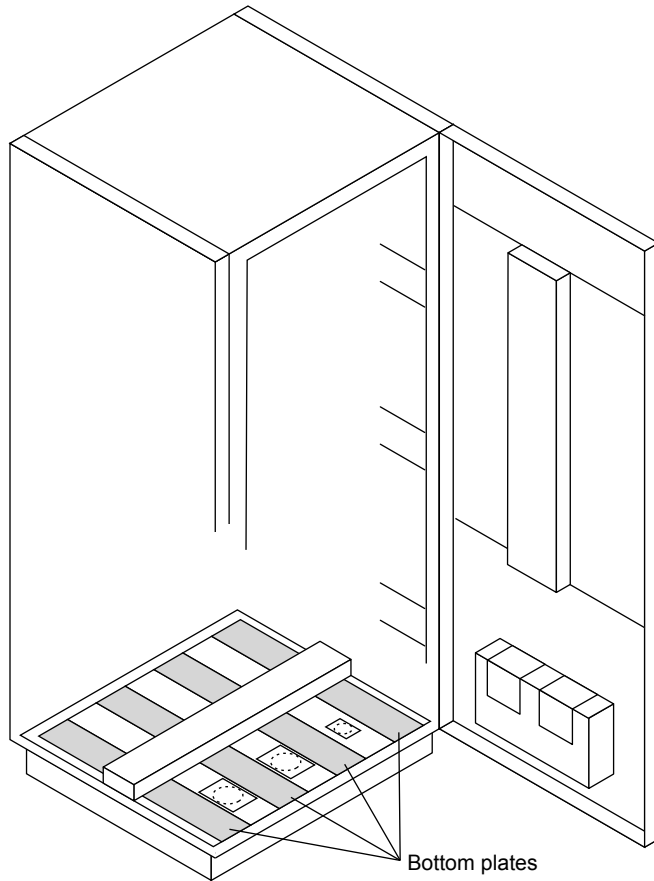

Figure Wiring of Console Type HIS (YPCKIT)

F030523.ai

Modifying the Cabinet Bottom Plates for Cable Wiring

Cables are passed through the holes in the bottom plates of the cabinet. The diameters of these holes can be changed to match the diameter of the cables. There are four bottom plates each at the front and rear of AF□20□/ACB21 specifically for signal cable wiring. There are three bottom plates each at the front and rear of AF□40□/ACB41 specifically for signal cable wiring.



F030504.ai

Figure Bottom Plates of AF□20□/ACB21

To modify the bottom plates, follow these steps.

1. Remove the bottom plate to be modified.

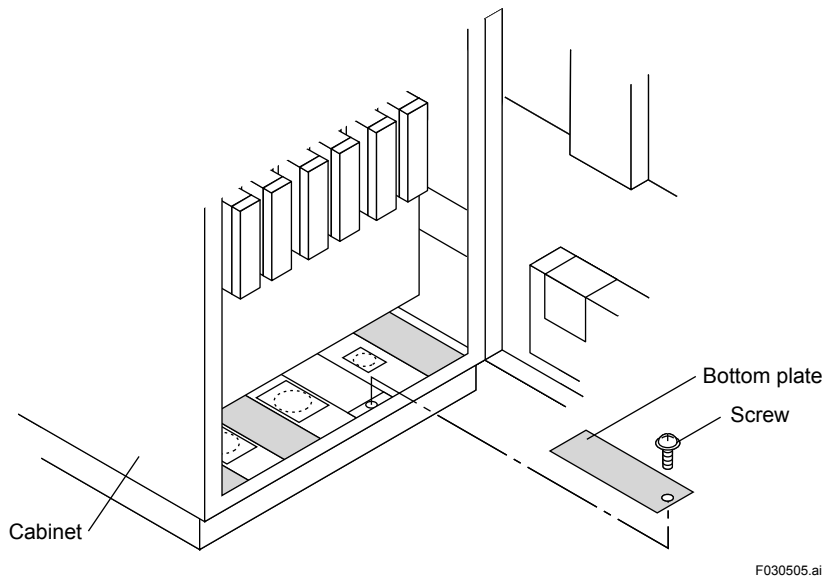

Figure Removing the Bottom Plate

2. Turn the bottom plate upside down so that the bottom faces upwards.
3. Use a wire cutter or another appropriate tool to remove sections of the bottom plate so that a hole large enough for the cable to pass through is made. Do not cut the sponge pad on the reverse side of the plate.
4. Cut and remove the area protective padding approximately 20 mm inside the opening made in the preceding step.
5. Turn the rim of the protective padding (width: 320 mm) inside out. This will protect the cable from the rough edges of the plate. The sponge pad has an adhesive surface. Peel the paper from the surface and stick the sponge pad to the plate.

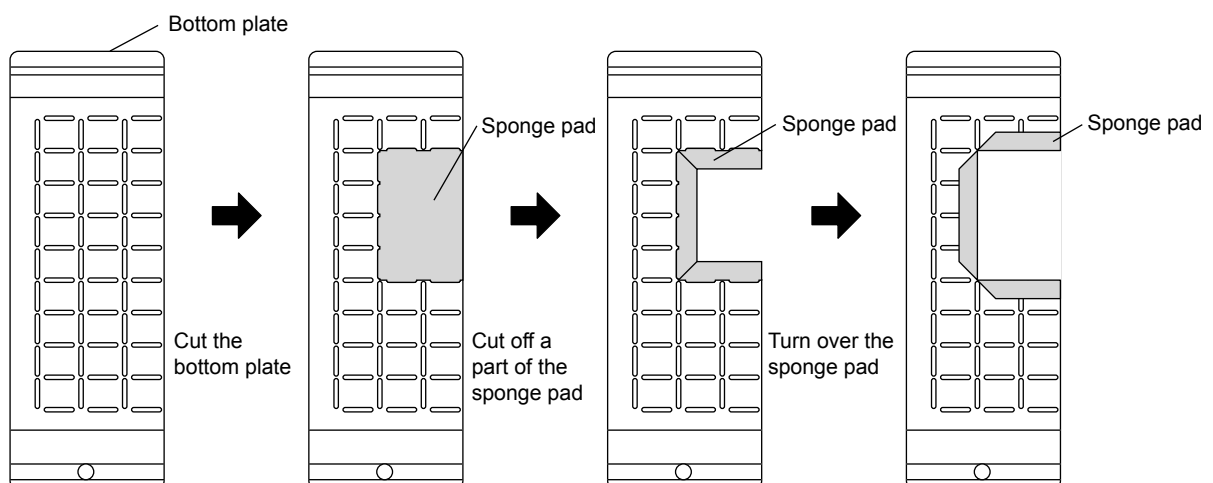

Figure Modifying the Bottom Plate

6. Replace the bottom plate.

3.6 Connecting Signal Cables with Fieldnetwork I/O (FIO)

This section describes the signal connections with Fieldnetwork I/O (FIO) used on the AFS30S/AFS30D, AFG30S/AFG30D, AFS40S/AFS40D, AFG40S/AFG40D, or AFF50S/AFF50D.

3.6.1 Combination of Fieldnetwork I/O (FIO) and Terminal Blocks

A pressure clamp terminal block or KS cable (also called a “Yokogawa-specific cable”) interface adapter is available for field-wiring, or an MIL cable provided by the user may be used.

**SEE
ALSO**

For the terminal arrangement of the pressure clamp terminals and terminal board, and the pin arrangement of the MIL connector, refer to “Field Connection Specifications (for FIO)” (GS 33Q06Q50-31E).

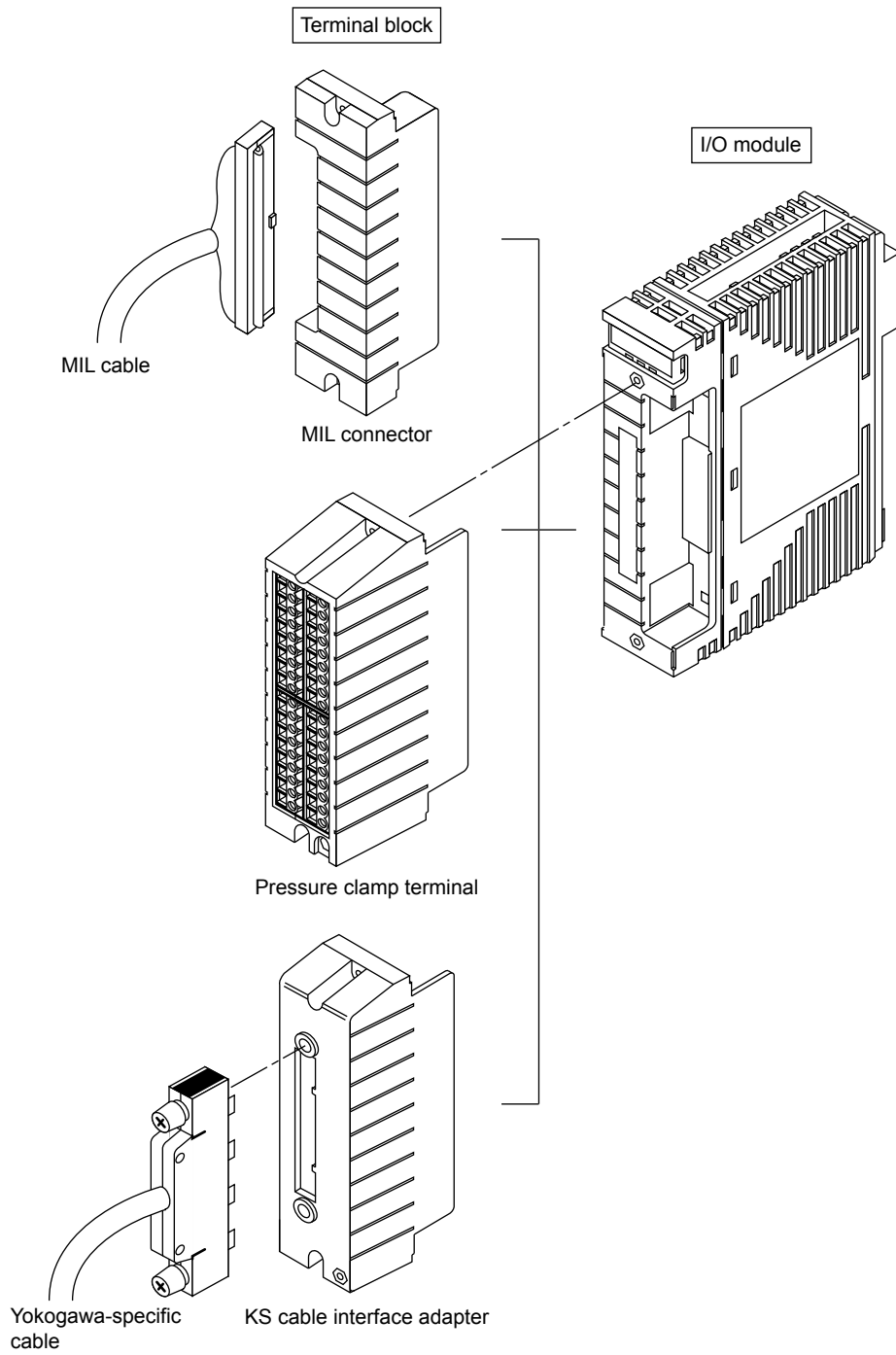

F030601.ai

Figure FIO Terminals

3.6.2 List of Signal Cables for Connection with FIO

The following table shows the list of signal cables connections with FIO.

Table Signal Cables for Connection with FIO (1/2)

Module	Name	I/O channels per Module	Connection Signal		
			Pressure Clamp Terminal	Yokogawa-specific Cable (*1)	MIL Cable
Analog I/O Modules					
AAI141	Analog Input Module (4 to 20 mA, Non-Isolated)	16	x	x	x
AAV141	Analog Input Module (1 to 5 V, Non-Isolated)	16	x	x	x
AAV142	Analog Input Module (-10 to +10 V, Non-Isolated)	16	x	x	x
AAI841	Analog I/O Module (4 to 20 mA Input, 4 to 20 mA Output, Non-Isolated)	8 input/8 output	x	x	x
AAB841	Analog I/O Module (1 to 5 V Input, 4 to 20 mA Output, Non-Isolated)	8 input/8 output	x	x	x
AAV542	Analog Output Module (-10 to +10 V, Non-Isolated)	16	x	x	x
AAI143	Analog Input Module (4 to 20 mA, Isolated)	16	x	x	x
AAI543	Analog Output Module (4 to 20 mA, Isolated)	16	x	x	x
AAV144	Analog Input Module (-10 to +10 V, Non-Isolated)	16	x	x	x
AAV544	Analog Output Module (-10 to +10 V, Non-Isolated)	16	x	x	x
AAT141	TC/mV Input Module (TC: R, J, K, E, T, B, S, N /mV: -100 to 150 mV, Isolated)	16	x	–	x(*3)
AAR181	RTD Input Module (RTD: Pt100 Ω, Isolated)	12	x	–	x
AAI135	Analog Input Module (4 to 20 mA, Isolated Channels)	8	x	x	x
AAI835	Analog I/O Module (4 to 20 mA, Isolated Channels)	4 input/4 output	x	x	x
AAT145	TC/mV Input Module (TC: R, J, K, E, T, B, S, N /mV: -100 to 150 mV, Isolated Channels)	16	–	x(*2)	–
AAR145	RTD/POT Input Module (RTD: Pt100 Ω /POT: 0 to 10 kΩ, Isolated Channels)	16	–	x(*2)	–
AAP135	Pulse Input Module (Pulse Count, 0 to 10 kHz, Isolated Channels)	8	x	x	x
AAP149	Pulse Input Module for compatible PM1 (Pulse Count, 0 to 6 kHz, Non-Isolated)	16	–	x	–
AAP849	Pulse Input/Analog Output module for compatible PAC (Pulse Count input, 4 to 20 mA output, Non-Isolated)	8 input/8 output	–	x	–

x : Can be connected.

– : Cannot be connected.

*1: Yokogawa-specific cable for connecting I/O Module and a terminal board, etc.

*2: Can be connected directly with a Yokogawa-specific cable, without a terminal block.

*3: When a MIL connector cable is connected, AAT141 modules can be used as mV-input modules.

Table Signal Cables for Connection with FIO (2/2)

Module	Name	I/O channels per Module	Connection Signal		
			Pressure Clamp Terminal	Yokogawa-specific Cable (*1)	MIL Cable
Digital I/O Modules					
ADV151	Digital Input Module (24 V DC, 4.1 mA)	32	x	x	x
ADV551	Digital Output Module (24 V DC, 100 mA)	32	x	x	x
ADV141	Digital Input Module (100 to 120 V AC, 4.7 mA)	16	x	x(*2)	–
ADV142	Digital Input Module (220 to 240 V AC, 6.2 mA/ch)	16	x	x(*2)	–
ADV157	Digital Input Module (24 V DC, 4.1 mA, Pressure Clamp Terminal Support Only)	32	x	–	–
ADV557	Digital Output Module (24 V DC, 100 mA, Pressure Clamp Terminal Support Only)	32	x	–	–
ADV161	Digital Input Module (24 V DC, 2.5 mA)	64	–	x(*2)	x
ADV561	Digital Output Module (24 V DC, 100 mA)	64	–	x(*2)	x
ADR541	Relay Output Module (24 to 110 V DC/100 to 240 V AC)	16	x	x(*2)	–
ADV859	Digital I/O Module for Compatible ST2 (Isolated Channels)	16 input /16 output	–	x(*2)	–
ADV159	Digital Input Module for Compatible ST3 (Isolated Channels)	32	–	x(*2)	–
ADV559	Digital Output Module for Compatible ST4 (Isolated Channels)	32	–	x(*2)	–
ADV869	Digital I/O Module for Compatible ST5 (Common Minus Side Every 16-Channel)	32 input /32 output	–	x(*2)	–
ADV169	Digital Input Module for Compatible ST6 (Common Minus Side Every 16-Channel)	64	–	x(*2)	–
ADV569	Digital Output Module for Compatible ST7 (Common Minus Side Every 16-Channel)	64	–	x(*2)	–
Communication Modules					
ALR111	RS-232C Communication Module (1200 bps to 115.2 kbps)	2 port	–	x (D-SUB9 pin) (*2)	–
ALR121	RS-422/RS-485 Communication Module (1200 bps to 115.2 kbps)	2 port	–	x (M4 terminal block 5-pole) (*2)	–
ALE111	Ethernet Communication Module (10 Mbps)	1 port	–	x (RJ-45) (*2)	–
ALF111	Foundation Fieldbus (FF-H1) Communication Module (31.25 kbps)	4 port	x	x(*2)	–
ALP111	PROFIBUS-DP Communication Module	1 port	–	x(*2)	–
Analog I/O Modules with Built-in Barrier					
ASI133	Analog Input Module (4 to 20 mA, Isolated)	8	x	–	–
ASI533	Analog Output Module (4 to 20 mA, Isolated)	8	x	–	–
AST143	TC/mV Input Module (TC: B, E, J, K, N, R, S, T / mV: -100 to 150 mV, -50 to 75 mV, Isolated)	16	x	–	–
ASR133	RTD/POT Input Module (RTD: Pt50, Pt100, Pt200, Pt500, Pt1000, Ni100, Ni200, Ni120 / POT: 0 to 10 kΩ, Isolated)	8	x	–	–
Digital I/O Modules with Built-in Barrier					
ASD143	Digital Input Module (NAMUR compatible, Isolated)	16	x	–	–
ASD533	Digital Output Module (Isolated)	8	x	–	–

x : Can be connected.

– : Cannot be connected.

*1: Yokogawa-specific cable for connecting I/O Module and a terminal board, etc.

*2: Can be connected directly with a Yokogawa-specific cable, without a terminal block.

3.6.3 Connecting Signal Cables with FIO

Pressure Clamp Terminal

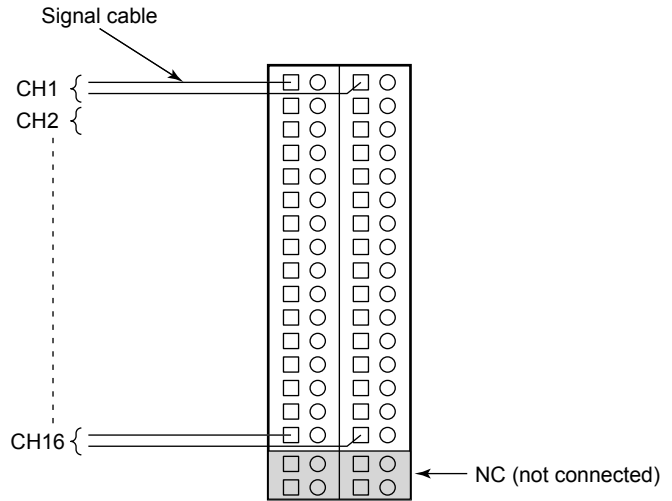
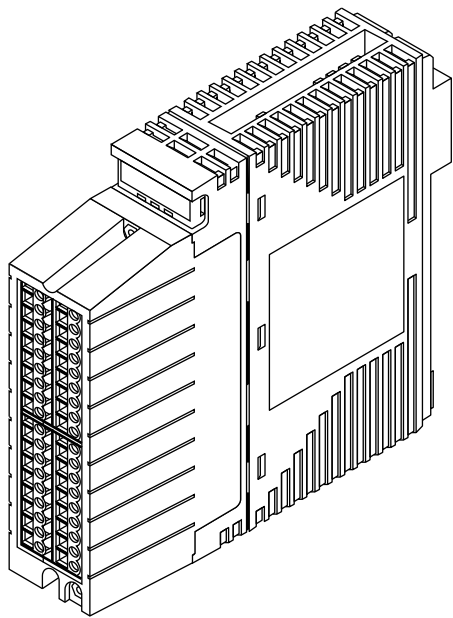

Example of Analog module AAI141

F030602.ai

Figure I/O Module with Pressure Clamp Terminal

Dual-redundant Pressure Clamp Terminal

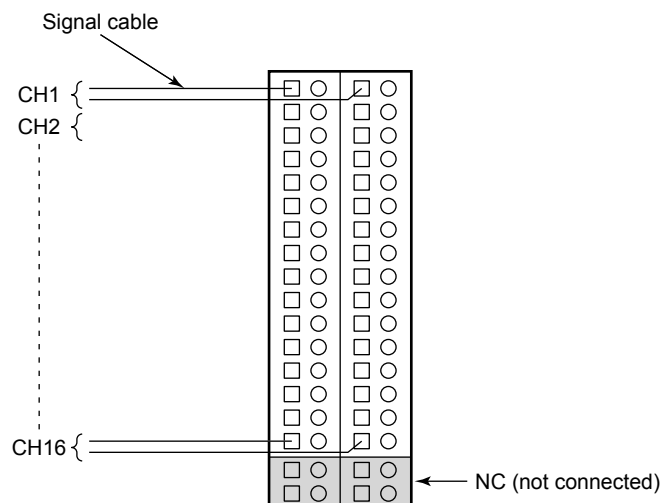
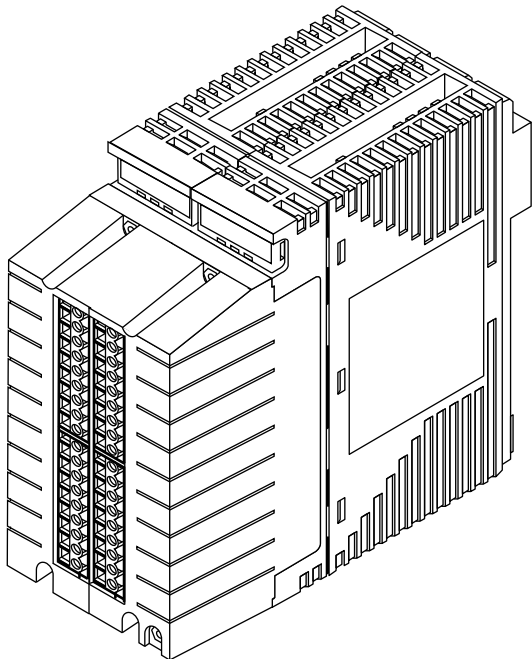

Example of Analog module AAI141

F030603.ai

Figure I/O Module with Dual-redundant Pressure Clamp Terminal

KS Cable Interface Adapter

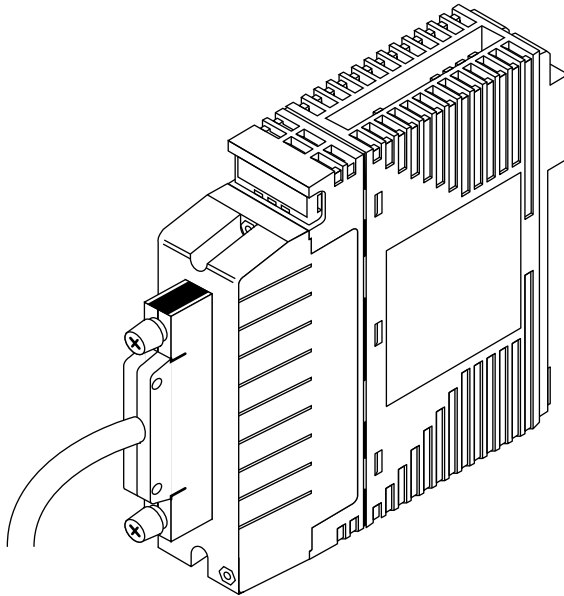

F030604.ai

Figure I/O Module with KS Cable Interface Adapter

The I/O modules are arranged in a dual-redundant configuration on the terminal board.

Connecting Signal Cables with Analog I/O Module

Signal cables are connected to different terminals according to the devices to be connected as listed below:

Table Signal Names and I/O Signals of Analog I/O Module

Model Name	Single Name	I/O Signal		
AAI141 AAI841 AAI143	IN□A	2-wire transmitter input +	Current input -	-
	IN□B	2-wire transmitter input - (setting pin: 2-wire input)	Current input + (setting pin: 4-wire input)	
AAI135 AAI835 (*1)	IN□A	2-wire transmitter input +	-	-
	IN□B	2-wire transmitter input -	Current input +	
	IN□C	-	Current input -	
AAR181 (*2)	IN□A	Resistance temperature detector input A	-	-
	IN□B	Resistance temperature detector input B		
	IN□C	Resistance temperature detector input B		
AAR145	IN□A	Resistance temperature detector input A	Potentiometer input, 100%	-
	IN□B	Resistance temperature detector input B	Potentiometer input, 0%	
	IN□C	Resistance temperature detector input B	Potentiometer input, variable	
AAP135	IN□A	2-wire power supply source	-	3-wire power supply source
	IN□B	2-wire power supply signal	2-wire voltage, contact +	3-wire power supply +
	IN□C	-	2-wire voltage, contact -	3-wire power supply -

□ is channel number.

*1: If the power to models AAI141, AAI841, AAI135 and AAI835 is off or abnormal, the current input loop is in the open state. Do not use current signals with other receiving devices. When in use, also use an external receiver resistance in the voltage mode (Shunt resistant module part no. A1080RZ 250 ohm).

*2: Wiring resistance for A and C must be identical.

Connecting Signal Cables with Pulse Input Module AAP135

The AAP135 receives contact ON/OFF, voltage pulse and current pulse. Refer to the figures below for details on how to connect signal cables since the items to be set by the system generation builder depend on the input pulse types.

When Receiving No-Voltage Contact Signals (1)

For the relay contacts or transistor contacts, connect as follows.

Pulse input frequency should be 0 to 800 Hz. Max. frequency differs due to the wiring effect, etc.

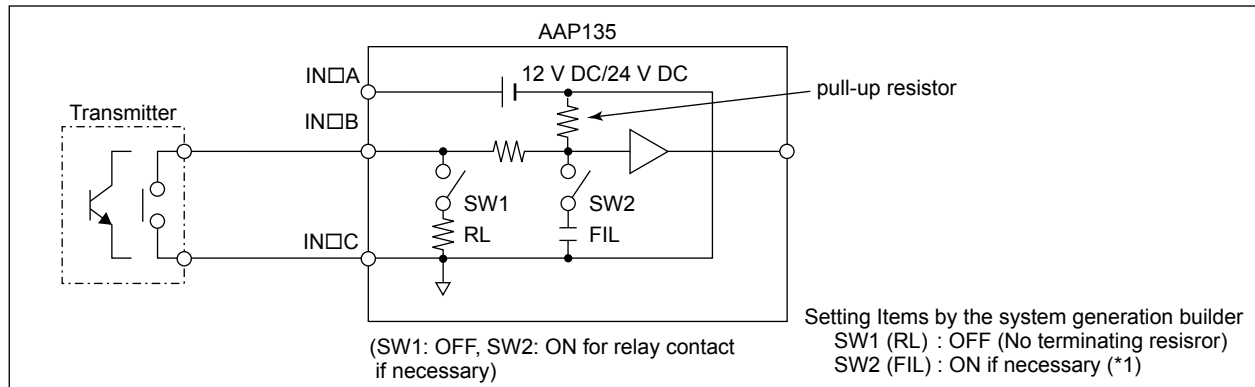

F030605.ai

Figure No-Voltage contact Input (1)

When Receiving No-Voltage Contact Signals (2)

Carry out connection as follows if a current is needed to flow to the relay contacts or transistor contacts.

When receiving transistor contact signal of more than 800 Hz frequency, connect as follows.

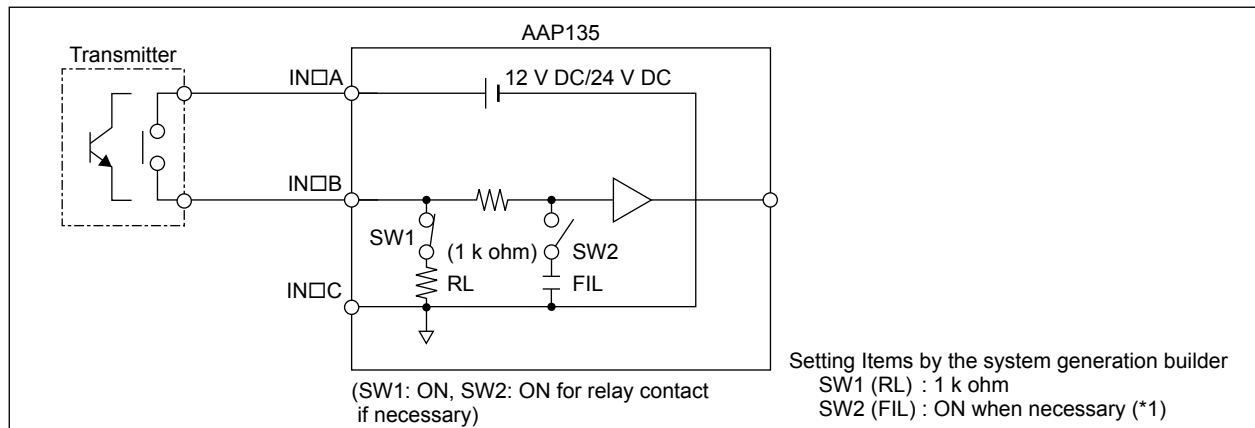

F030606.ai

Figure No-Voltage contact Input (2)

*1: When there is a chattering noise at a mechanical relay, set the SW2 to ON to eliminate the noise.

When Receiving Voltage Pulse Signals

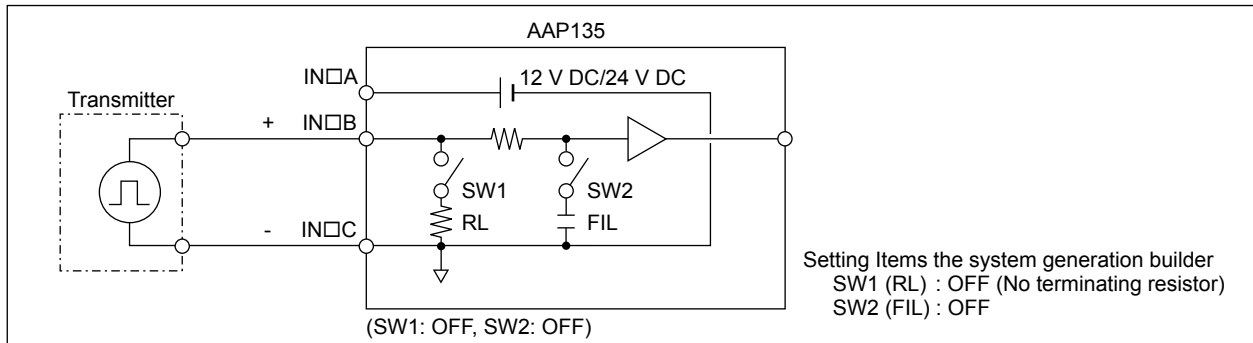

F030607.ai

Figure Voltage Pulse Input

When Receiving Current Pulse By Using the Internal Power to Drive the Transmitter (2-wire power supply type)

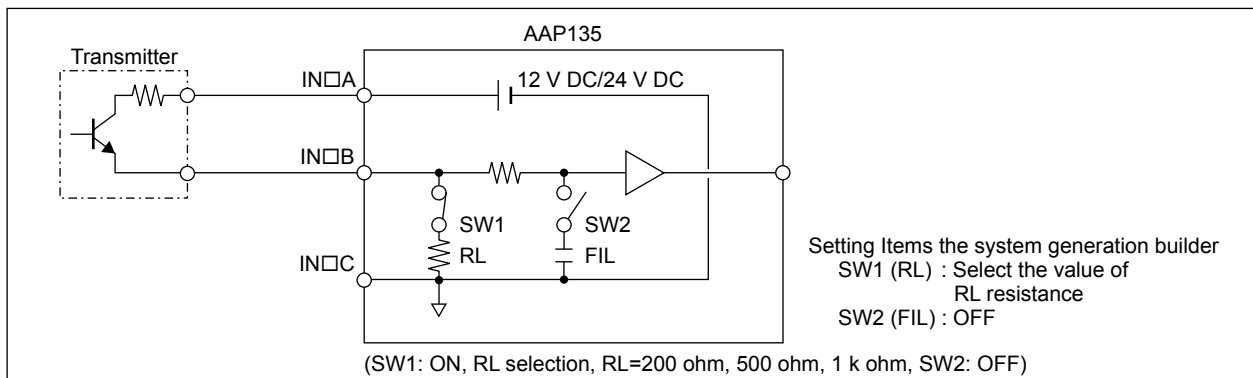

F030608.ai

Figure 2-Wire Power Supply Type

This method supplies power to the transmitter, and receives the transmitter output signals as the current pulse signals. By using the input load resistance (select from None, 200 ohm, 500 ohm, 1 k ohm), the current signal is converted to the voltage level pulse and receives it.

When Receiving Voltage Pulse By Using the Internal Power to Drive the Transmitter (3-wire power supply type)

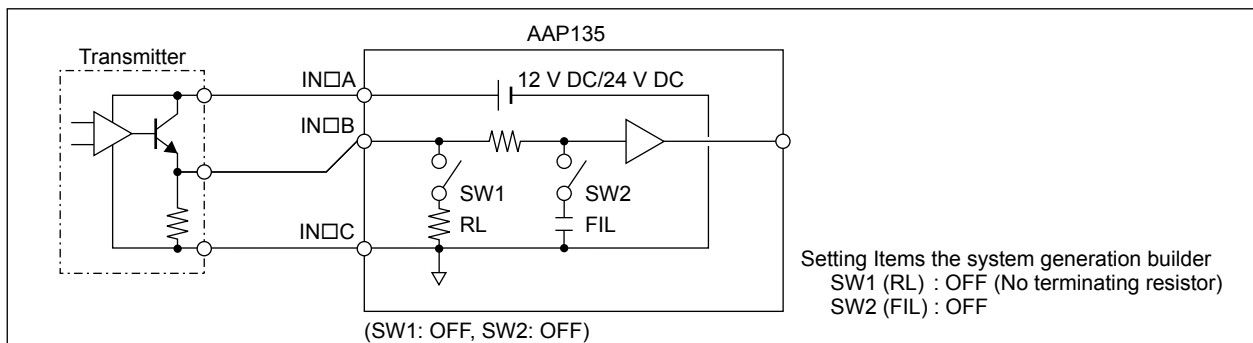

F030609.ai

Figure 3-Wire Power Supply Type

Connecting Terminal Board with FIO

The I/O module equipped with a KS cable interface adapter can be connected to the terminal board using a Yokogawa-specific cable. Field signals are connected using the terminal board.

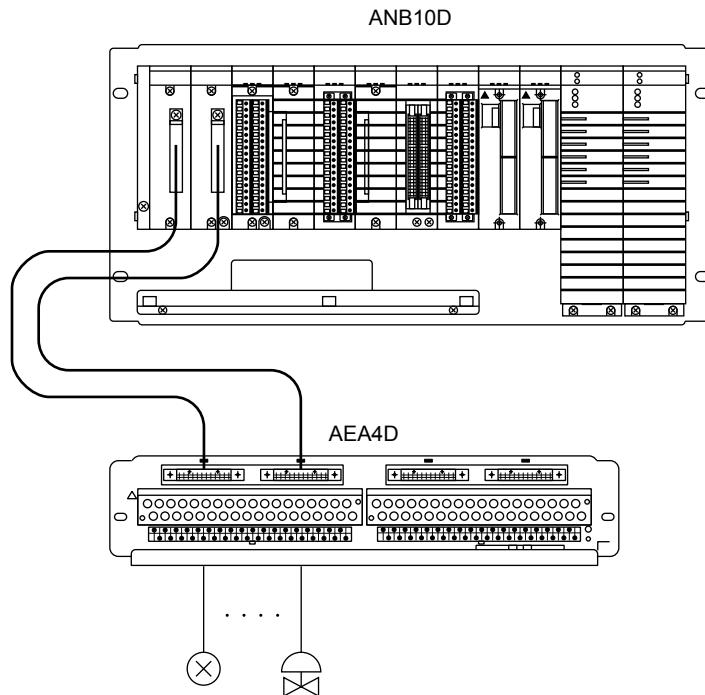

F030610.ai

Figure Example of Terminal Board Connection with Dual-redundant I/O Module

**SEE
ALSO**

For details of the KS cable interface adapter model and the cable model, refer to “Field Connection Specifications (for FIO)” (GS 33Q06Q50-31E).

Connecting Relay Board with Digital I/O Module

An example of the connection of the mechanical relay board ARM55D with the Digital I/O Module ADV551 is shown below.

ADV551+ATD5A adapter

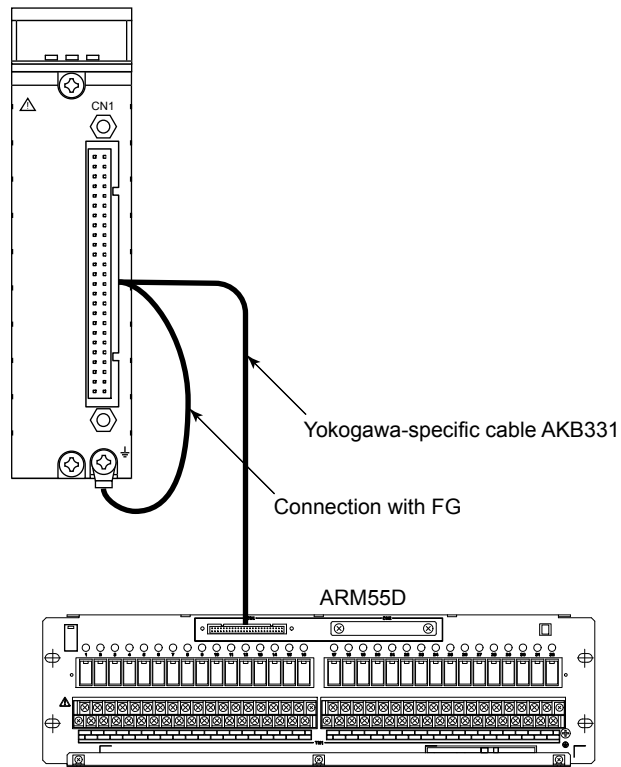

F030611.ai

Figure Example of Relay Board Connection with Digital I/O Module

3.6.4 Implementation and Cable Connection of Fieldbus Communication Module ALF111

This section describes the implementation and cable connection of the Foundation Fieldbus Communication Module ALF111.

Foundation fieldbus H1 (Low Speed Voltage Mode) is called Foundation fieldbus, Fieldbus, H1 Fieldbus, FF, or FF-H1 in this manual.

Example of Implementation of Fieldbus Communication Module ALF111

To connect Fieldbus using the ALF111, the power supply unit for the Fieldbus must be prepared as shown below.

The example of the implementation and the wiring of the ALF111 is shown below.

For the implementation of the ALF111 and the relevant devices, follow the implementation conditions for the devices. 1 U (unit) = 44.45 mm.

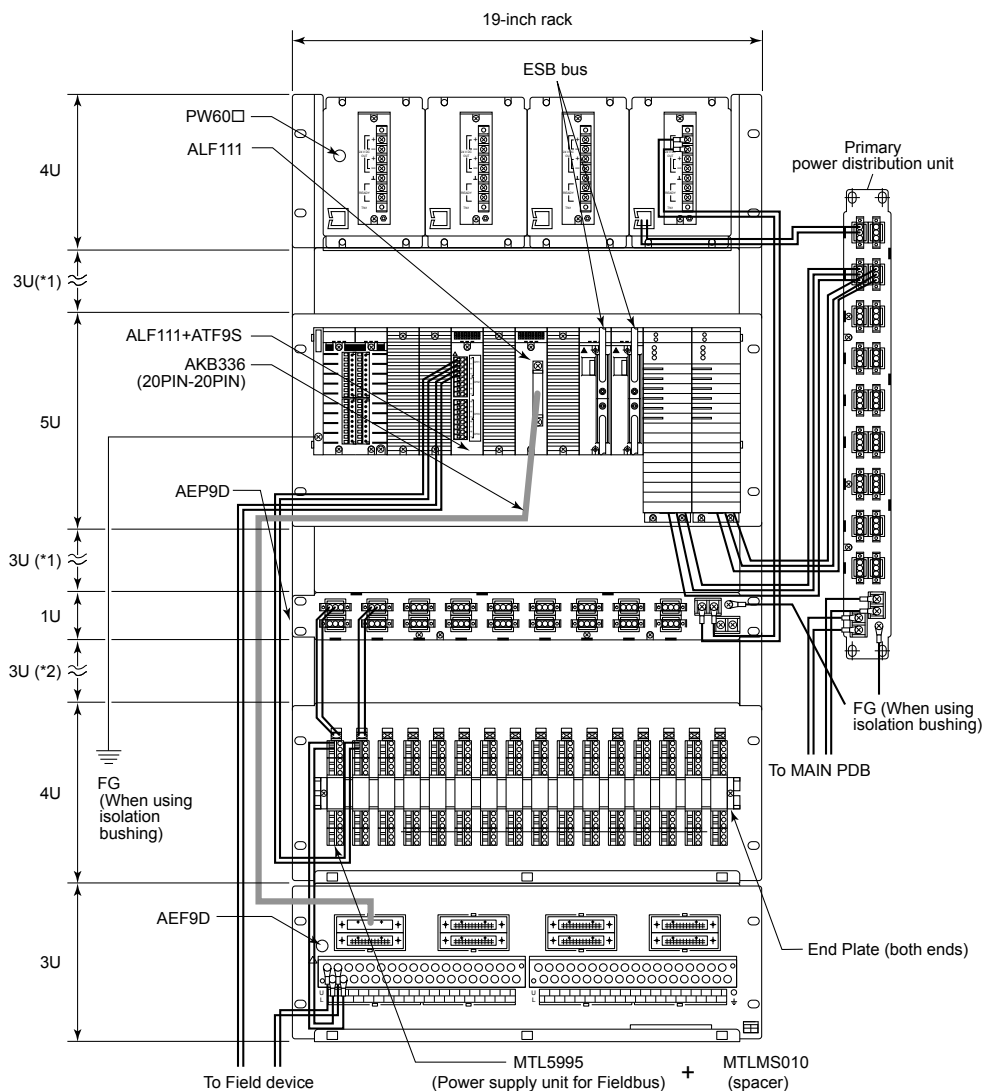

- *1: Reserve a space of 3U for heat radiation.
 *2: Reserve a space of 3U for heat radiation and wiring.

Figure Example of ALF111 Implementation

F030612.ai

Connection of Fieldbus Communication Module ALF111

The Fieldbus can be connected by attaching a pressure clamp terminal block or by using a Yokogawa-specific cable for connection to the terminal board (M4 screw).

Connection with a pressure clamp terminal

ALF111 and ATF9S

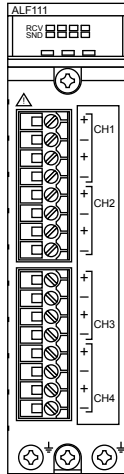

The ON/OFF setting of terminating resistor can be made on the pressure clamp terminal.

Connection with a terminal board

ALF111

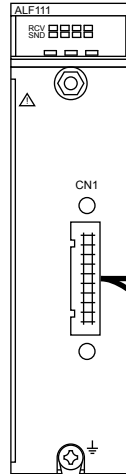

A terminating resistor is necessary.

Yokogawa-specific cable (AKB336)(*1)

Connection with FG

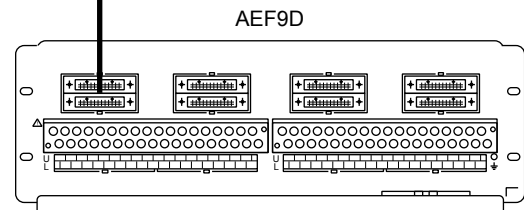

F030613.ai

*1: If Type A cables are used for Fieldbus wiring, double the length of the AKB336 cable and include its length in with the total length of the branch cables. Keep the trunk cable length (trunk line cable length) within 1900 m (total branch length).

Figure Fieldbus Wiring for ALF111

**SEE
ALSO**

For details of the Fieldbus connection and wiring work, refer to "Fieldbus Technical Information" (TI 38K03A01-01E).

Fieldbus Wiring for ALF111 with Pressure Clamp Terminal Block

The signal cables from the field device should be connected to the + and - terminals of the pressure clamp terminal block (ATF9S).

Do not connect anything to the terminals of channels that are not used.

When installing the node unit mounted with the ALF111 on the 19-inch rack, connect the shield lines of Fieldbus cables from the field devices to the FG terminal of the ATF9S. If two or more channels are used, no more than two shield lines can be connected to one FG terminal.

When installing the node unit mounted with the ALF111 in the control station cabinet, connect the shield lines of Fieldbus cables to the shield ground bar within the cabinet (insulated from the cabinet itself), not to the FG terminal of the ATF9S.

The length of the connection cable between the power supply unit and the ALF111 should be less than one meter. Use a type A cable and connect the cable shield to the same potential as the FG terminal of the node if the cable length exceeds one meter.

Note that, when installing wiring within the cabinet, the shield line should be connected to the shield ground bar within the cabinet as well.

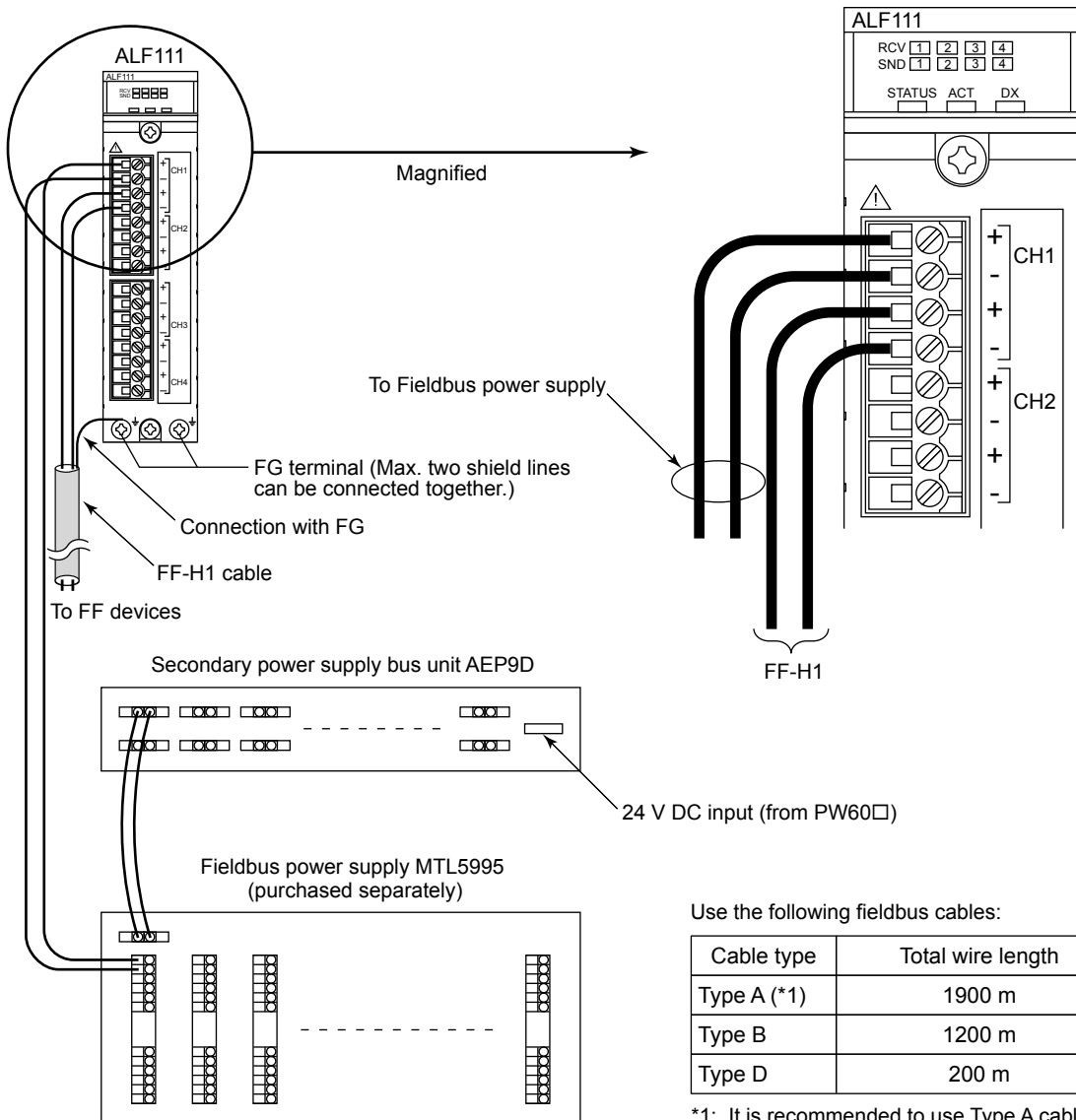
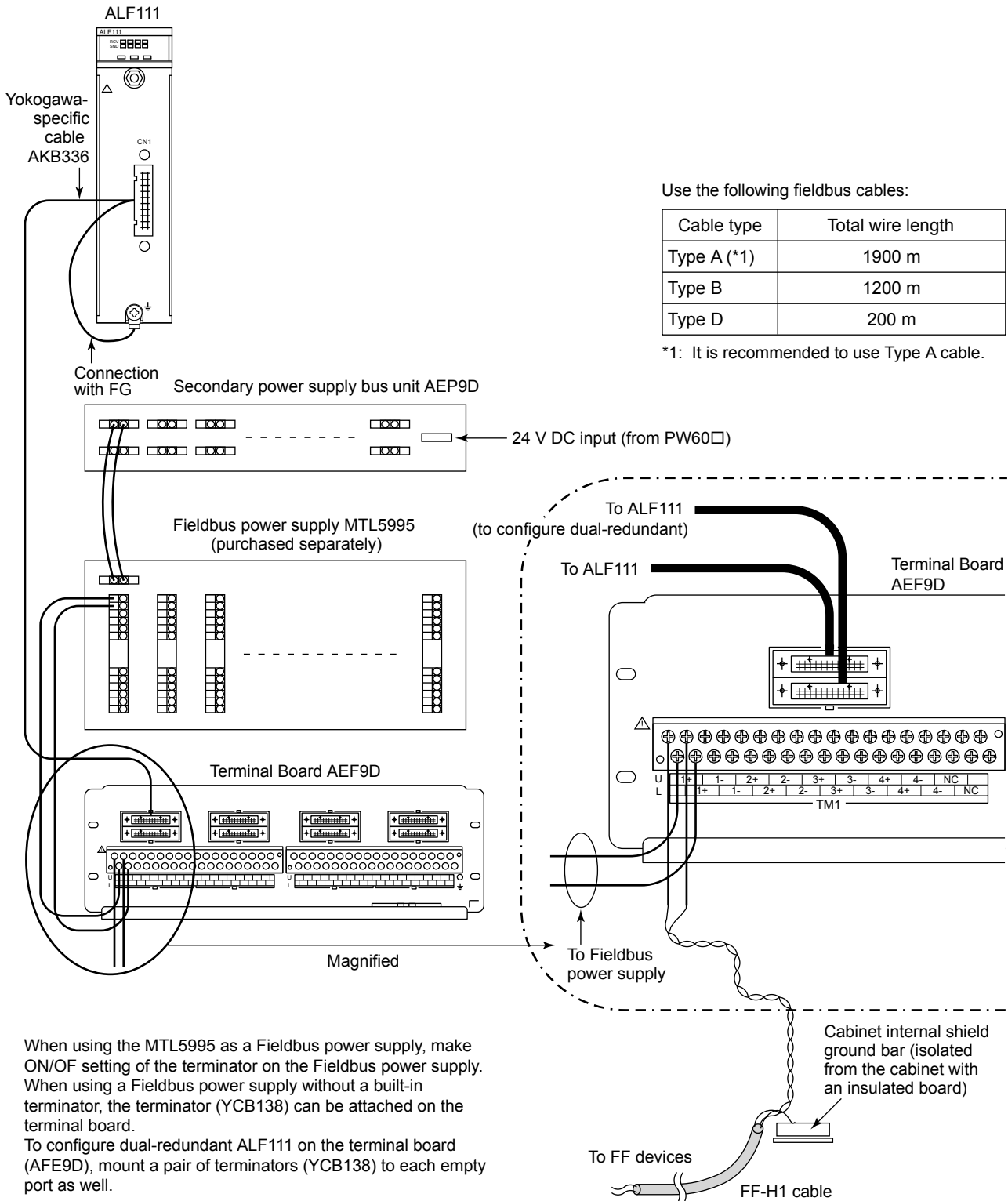

Figure Fieldbus Wiring for ALF111 with Pressure Clamp Terminal

F030614.ai

Fieldbus Wiring for ALF111 with Terminal Board



When using the MTL5995 as a Fieldbus power supply, make ON/OFF setting of the terminator on the Fieldbus power supply. When using a Fieldbus power supply without a built-in terminator, the terminator (YCB138) can be attached on the terminal board.

To configure dual-redundant ALF111 on the terminal board (AEF9D), mount a pair of terminators (YCB138) to each empty port as well.

Figure Fieldbus Wiring for ALF111 with Terminal Board

F030615.ai

Installation of Terminator to Terminal Board AEF9D

Make sure to install a terminator (YCB138) if the ALF111 (terminal board AEF9D) terminates the network, in other words, if the network is not terminated by a terminator in the power supply unit.

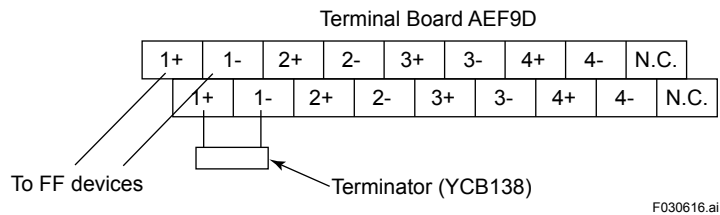

Figure Installation of Terminator to Terminal Board AEF9D



IMPORTANT

In the following condition, the vacant port should be terminated with a pair of terminators:

The AEF9D terminal board is used, the ALF111 is in a dual-redundant configuration, and any of the four ports is vacant.

3.7 Connecting Signal Cables with Remote I/O (RIO)

This section describes the signal connections with Remote I/O (RIO) used on the AFS10S/AFS10D, AFG10S/AFG10D, AFS20S/AFS20D, AFG20S/AFG20D, or PFCS/PFCD.

3.7.1 I/O Module Nests

I/O Modules Nests are available in the following types:

- AMN11: Nest for Analog I/O Modules
- AMN12: High-Speed Nest for Analog I/O Modules (for AF□10□ and AF□20□)
- AMN21: Nest for Relay I/O Modules
- AMN31: Nest for Terminal-type I/O Modules
- AMN32: Nest for Connector-type I/O Modules
- AMN33: Nest for Communication Modules
- AMN34: Nest for Multipoint Control Analog I/O Modules
- AMN51: Nest for Communication Cards and Ethernet Communication Modules (for PFCS□ only)
- AMN52: Nest for Profibus Communication Module (in PFCS□ only)

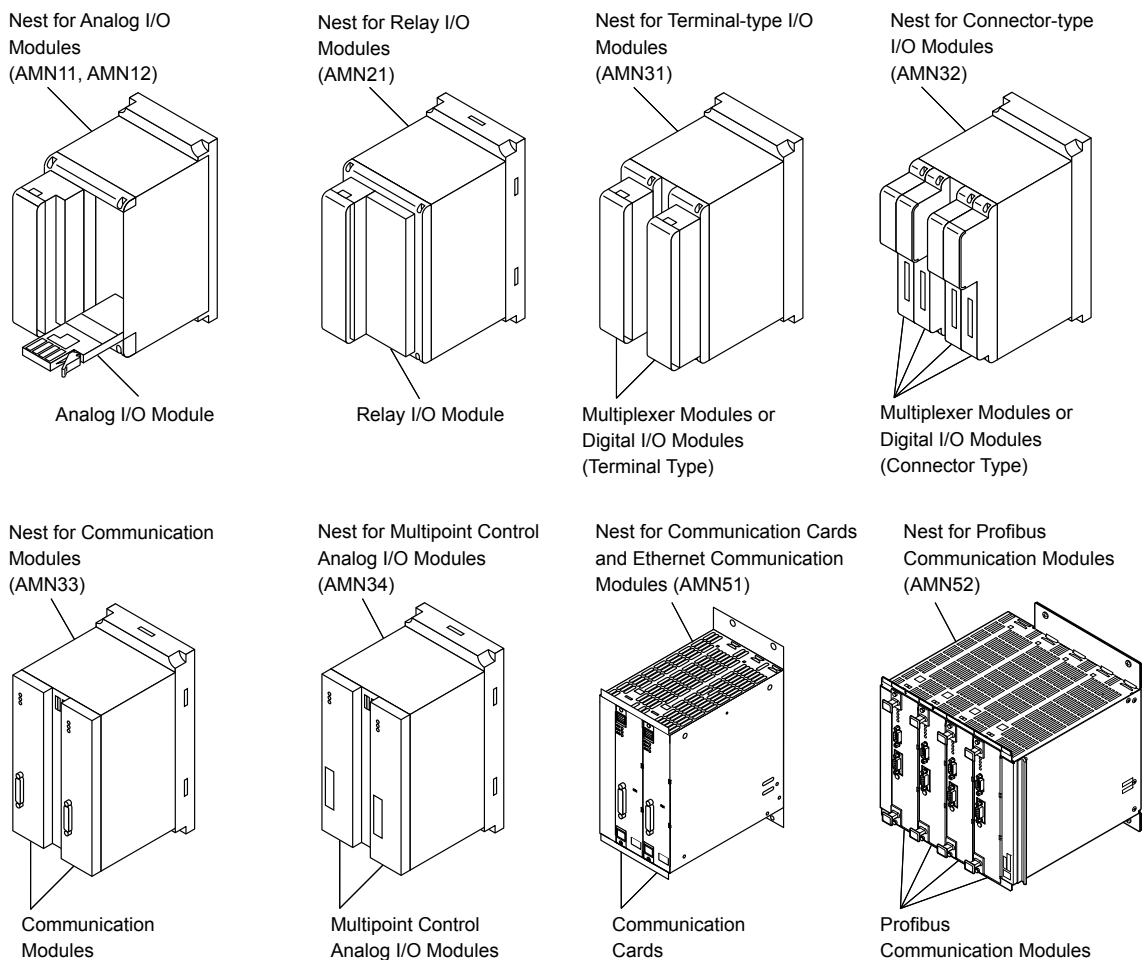

F030730.ai

Figure I/O Module Nest Configuration

3.7.2 Signal Cables for Connection with RIO

The following table lists the signal cables for connection with RIO.

Table Signal Cables for Connection with RIO

Signal Type	Model	Module Type	I/O Points Per Module	Signal Connection	
Analog I/O Modules	AAM10	Current/Voltage Input Module (Simplified Type)	1	Terminals	
	AAM11	Current/Voltage Input Module	1		
	AAM11B	Current/Voltage Input Module (supports BRAIN)	1		
	AAM21	mV, Thermocouple, and RTD Input Module	1		
	AAM21J	mV, Thermocouple and RTD Input Module (conforms to IEC 584-1995, IEC 751-1995)	1		
	APM11	Pulse Input Module	1		
	AAM50	Current Output Module	1		
	AAM51	Current/Voltage Output Module	1		
Relay I/O Modules	AMC80	Multipoint Control Analog I/O Module	8 input/8 output	Connector	
	ADM15R	Relay Input Module	16	Terminals	
Multiplexer Modules	ADM55R	Relay Output Module	16		
	AMM12T	Voltage Input Multiplexer Module	16	Terminals	
	AMM22T	Thermocouple Input Multiplexer Module	16		
	AMM32T	RTD Input Multiplexer Module	16		
	AMM42T	2-Wire Transmitter Input Multiplexer Module	16		
	AMM52T	Current Output Multiplexer Module	16		
	AMM22TJ	Thermocouple Input Multiplexer Module (16 Points, Terminal Type, conforms to IEC 584-1995)	16		
	AMM32TJ	RTD Input Multiplexer Module (16 Points, Terminal Type, conforms to IEC 751-1995)	15	Connector	
	AMM22M	mV Input Multiplexer Module	16		
	AMM12C	Voltage Input Multiplexer Module	16		
	AMM22C	mV Input Multiplexer Module (16 Points, Connector Type)	16		
	AMM25C	mV Input Multiplexer Module with Thermocouple Interface (15 Points, Connector Type, RJC Input port added)	15		
AMM32C	RTD Input Multiplexer Module (16 Points, Connector Type)	16			
Digital I/O Modules	AMM32CJ	RTD Input Multiplexer Module (16 Points, Connector Type, conforms to IEC 751-1995)	16	Terminals	
	ADM11T	Contact Input Module (16 Points, Terminal Type)	16		
	ADM12T	Contact Input Module (32 Points, Terminal Type)	32		
	ADM51T	Contact Output Module (16 Points, Terminal Type)	16		
	ADM52T	Contact Output Module (32 Points, Terminal Type)	32		
	ADM11C	Contact Input Module (16 Points, Connector Type)	16		Connector
	ADM12C	Contact Input Module (32 Points, Connector Type)	32		
	ADM51C	Contact Output Module (16 Points, Connector Type)	16		
ADM52C	Contact Output Module (32 Points, Connector Type)	32			
Communication Modules	ACM11	RS-232C Communication Module	1ch	Terminals	
	ACM12	RS-422/RS-485 Communication Module	1ch		
	ACF11	Fieldbus Communication Module	1ch		
Communication Cards	ACM21	RS-232C General-purpose Communication Card	1ch	Connector	
	ACM22	RS-422/RS-485 General-purpose Communication Card	1ch	Terminals	
	ACM71	Ethernet Communication Module (for PFC□)	1ch	RJ-45 (10BASE-T) Connector	
	ACP71	Profibus Communication Module	1ch	D-Sub 9 pin Connector	

3.7.3 Connecting Signal Cables with Analog I/O Modules

Signal cables are connected to different terminals according to type of input and output signal as listed below:

Table Analog I/O Module Terminals and Connections

Module	Terminal	I/O signal		
AAM10 AAM11	A	2-wire transmitter input +	Current input + Current input -	Voltage input + Voltage input -
	B	2-wire transmitter input -		
	C			
AAM11B	A	BRAIN transmitter input +	Current input + Current input -	Voltage input + Voltage input -
	B	BRAIN transmitter input -		
	C			
AAM21 AAM21J	A		Resistance temperature detector input A	Potentiometer input 100%
	B	mV/thermocouple input +	Resistance temperature detector input B	Potentiometer input variable
	C	mV/thermocouple input -	Resistance temperature detector input B	Potentiometer input 0%
APM11	A		2-wire power supply source	3-wire power supply source
	B	2-wire voltage, contact +	2-wire power signal	3-wire power supply +
	C	2-wire voltage, contact -		3-wire power supply -
AAM50	A	Current output +	—	—
	B			
	C	Current output -		
AAM51	A	Current output +	Voltage output +	—
	B			
	C	Current output -	Voltage output -	

Analog I/O Modules AAM10, AAM11, AAM11B, AAM21, AAM21J, APM11, AAM50, AAM51

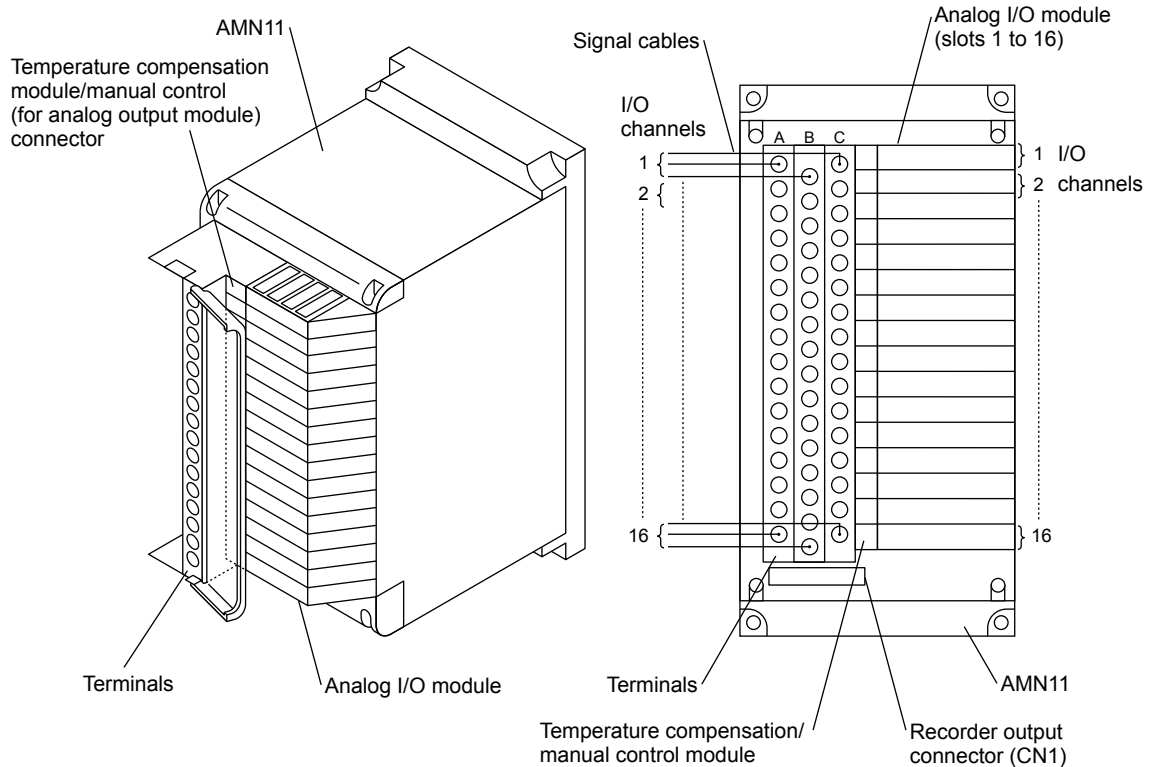

F030701.ai

Figure Analog I/O Module Cable Connection

Analog Input Modules AAM21, AAM21J for Resistance Temperature Detector Signal Input

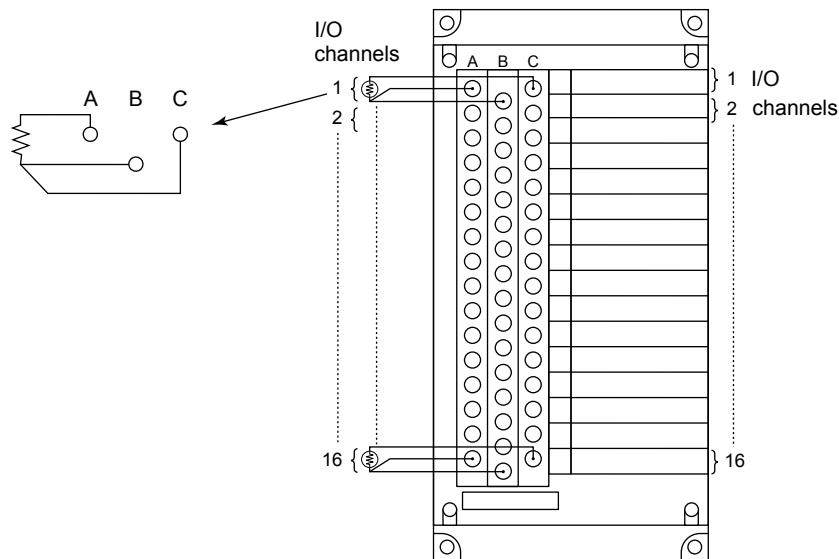

To output 1 to 5 V DC signals to a recorder, connect cable AKB301 to connector CN1. Connecting CN1 and terminal block TE16 via AKB301, for example, connects the terminal block with a recorder.

F030702.ai

Figure AAM21, AAM21J (for Resistance Temperature Detector Signal Input) Cable Connection

Connecting Signal Cables with Pulse Input Module APM11

The APM11 receives contact ON/OFF, voltage pulse and current pulse. Refer to the figures below for details on how to connect signal cables since the items to be set by the system generation builder depend on the input pulse types.

When Receiving No-Voltage Contact Signals (1)

For the relay contacts or transistor contacts, connect as follows.

Pulse input frequency should be 0 to 800 Hz. Max. frequency differs due to the wiring effect, etc.

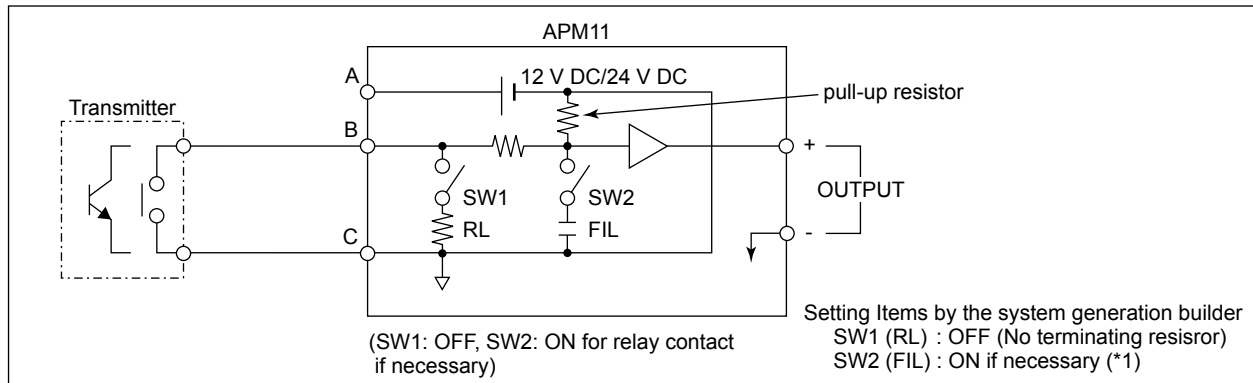

F030703.ai

Figure No-Voltage Input (1)

When Receiving No-Voltage Contact Signals (2)

Carry out connection as follows if a current is needed to flow to the relay contacts or transistor contacts.

When receiving transistor contact signal of more than 800 Hz frequency, connect as follows.

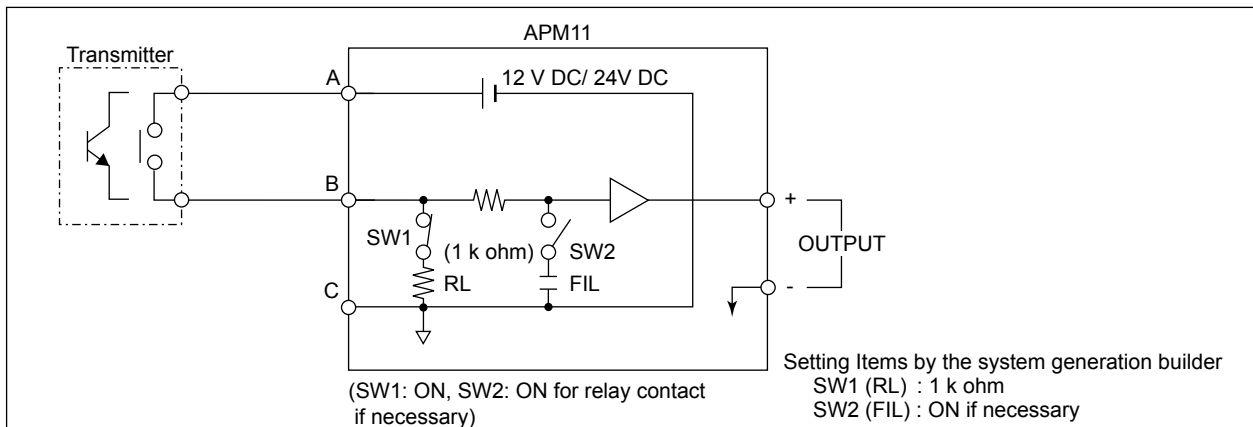

F030704.ai

Figure No-Voltage Input (2)

*1: When there is a chattering noise at a mechanical relay, set the SW2 to ON to eliminate the noise.

When Receiving Voltage Pulse Signals

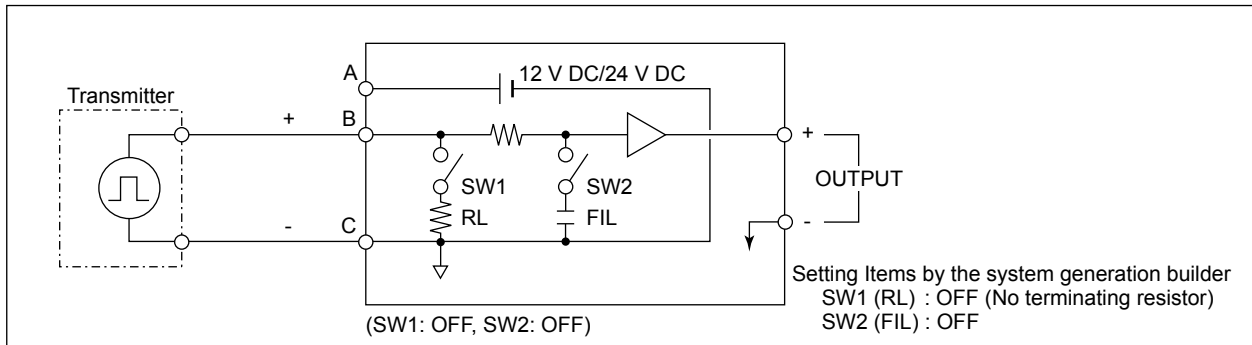

F030705.ai

Figure Voltage Pulse Input

When Receiving Current Pulse By Using the Internal Power to Drive the Transmitter (2-wire power supply type)

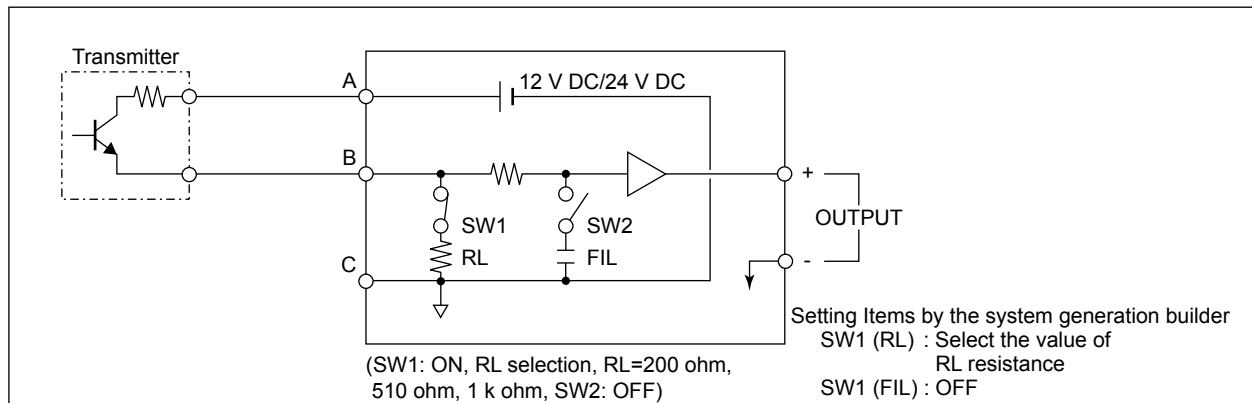

F030706.ai

Figure 2-Wire Power Supply Type

This method supplies power to the transmitter, and receives the transmitter output signals as the current pulse signals. By using the input load resistance (select from None, 200 ohm, 510 ohm, 1 k ohm), the current signal is converted to the voltage level pulse and receives it.

When Receiving Voltage Pulse By Using the Internal Power to Drive the Transmitter (3-wire power supply type)

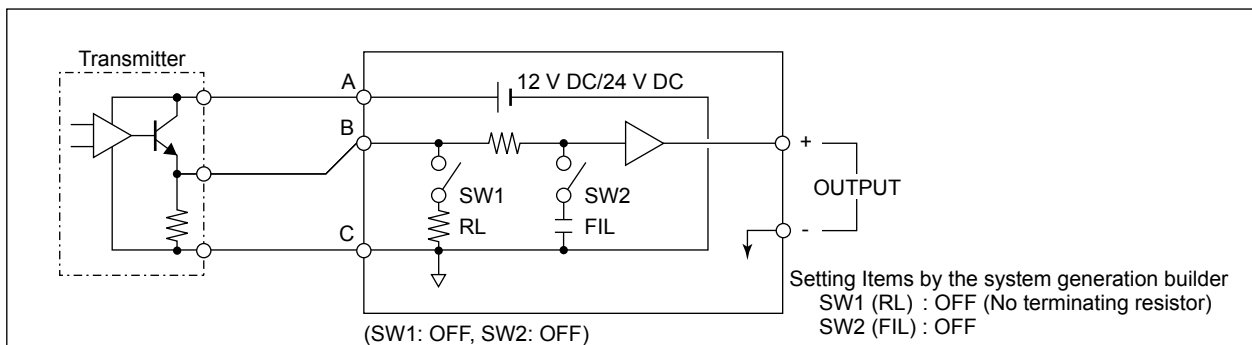

F030707.ai

Figure 3-Wire Power Supply Type

Redundant AAM50/AAM51

These modules output signals of 4 to 20 mA or 0 to 10 V.

They may be made redundant when they are set in the current output mode.

To make them redundant, two AAM50 or AAM51 modules must be installed in two adjacent slots beginning with an odd-number slot (1-2, 3-4, 13-14, 15-16) and set to be redundant, and adjacent terminals A and C must be connected to check their outputs against each other as shown below.

The AAM50 and AAM51 modules cannot be combined for redundancy.

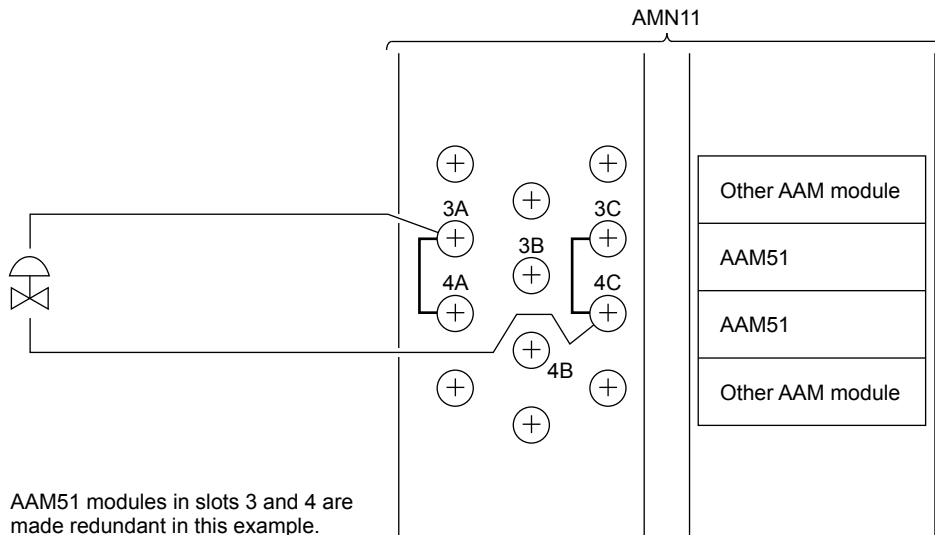

AAM51 modules in slots 3 and 4 are made redundant in this example.

F030708.ai

Figure Redundant Current Output Module AAM51

3.7.4 Connecting Signal Cables with Multipoint Control Analog I/O Module AMC80

Multipoint Control Analog I/O Module AMC80

Connect the shield of the Yokogawa-specific cable to the shield terminal.

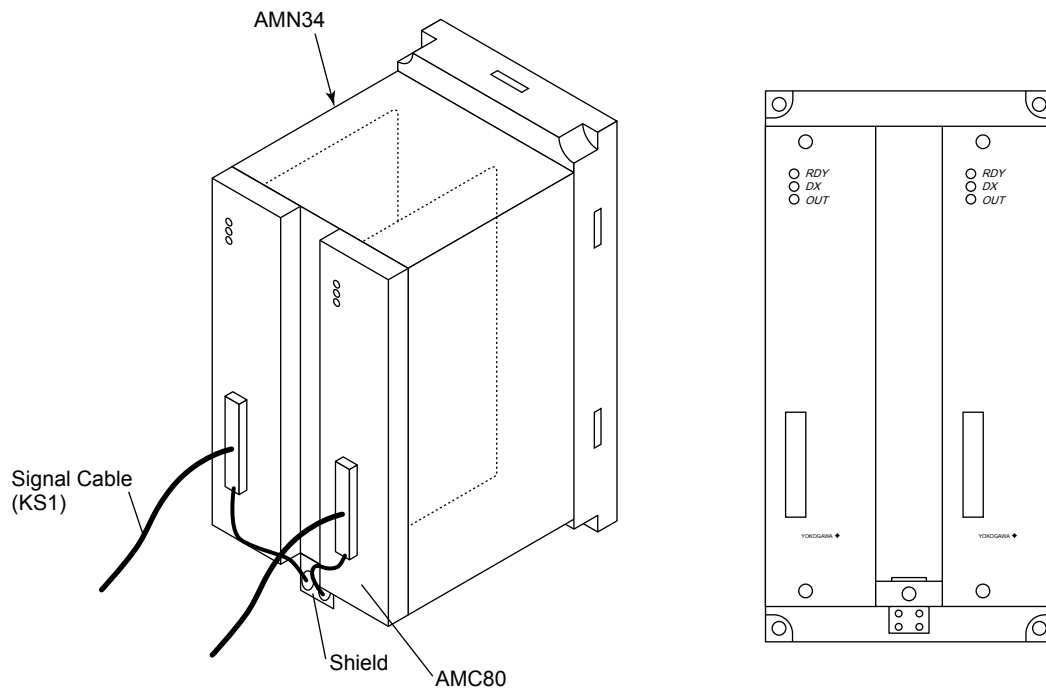

Figure AMC80 Signal Cable Connection

F030709.ai

Connecting Signal Cables with MCM Terminal Board

Two AMC80s can be set up in a dual-redundant configuration by connecting them to an MCM terminal board as shown in the figure below.

When the AMC80 is used in a single configuration, one MCM terminal board is required for each AMC80.



IMPORTANT

Do not set up AMC80s in the single mode when they are connected to a MCM terminal board in the dual-redundant configuration.

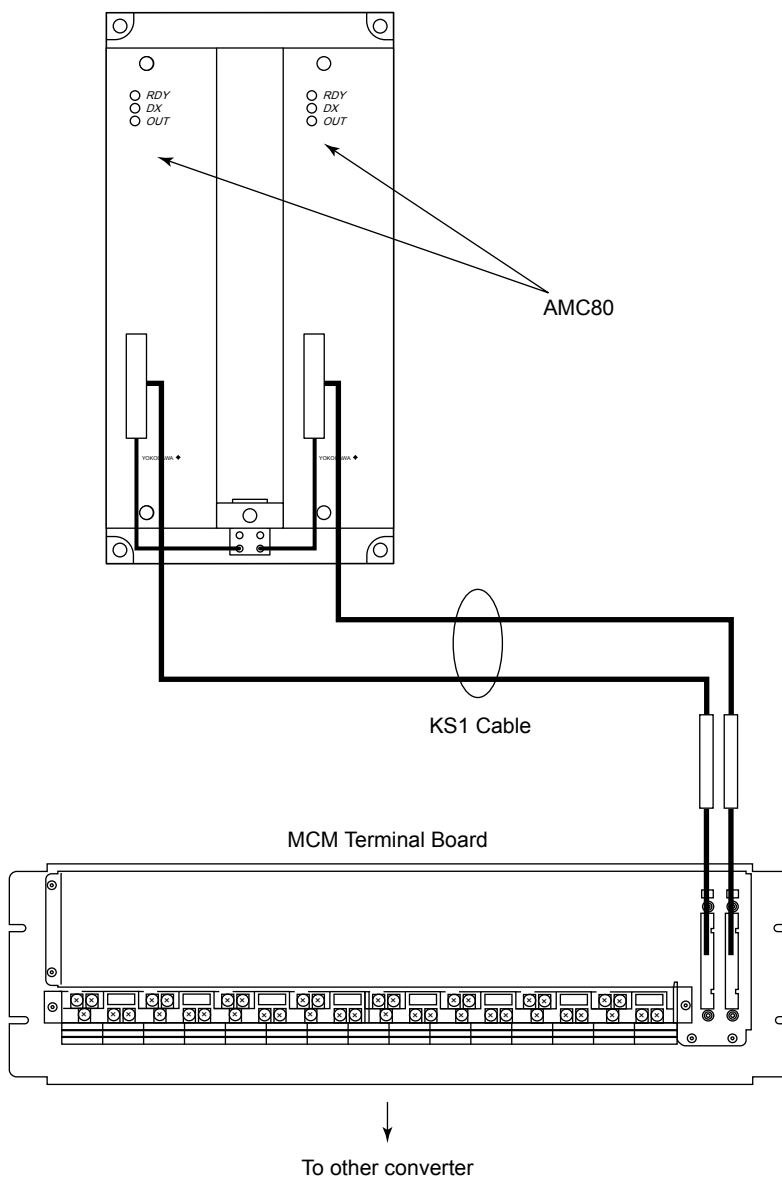

F030710.ai

Figure Example of Dual-redundant AMC80 Configuration

3.7.5 Connecting Signal Cables with Relay I/O Modules

Relay Input Module ADM15R

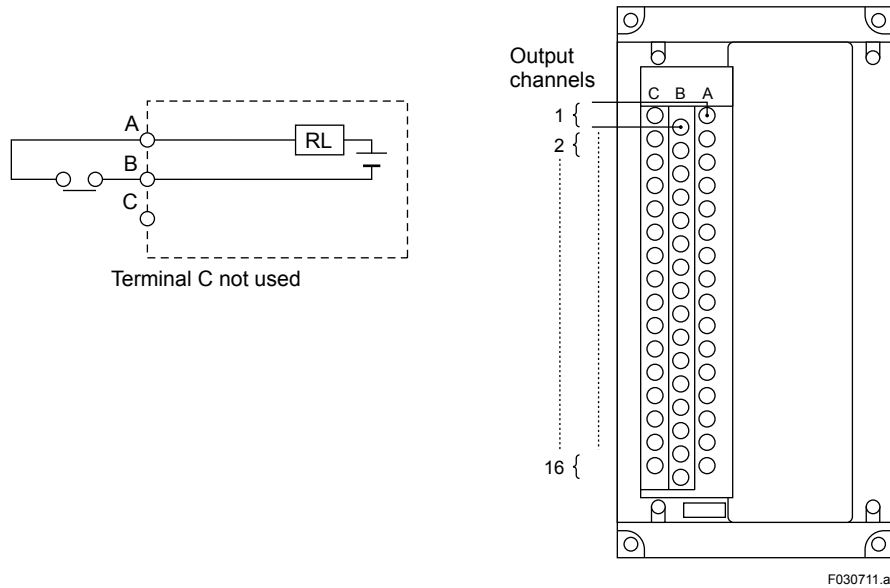

Figure Signal Cable Connection of Relay Input Module ADM15R

Relay Output Module ADM55R

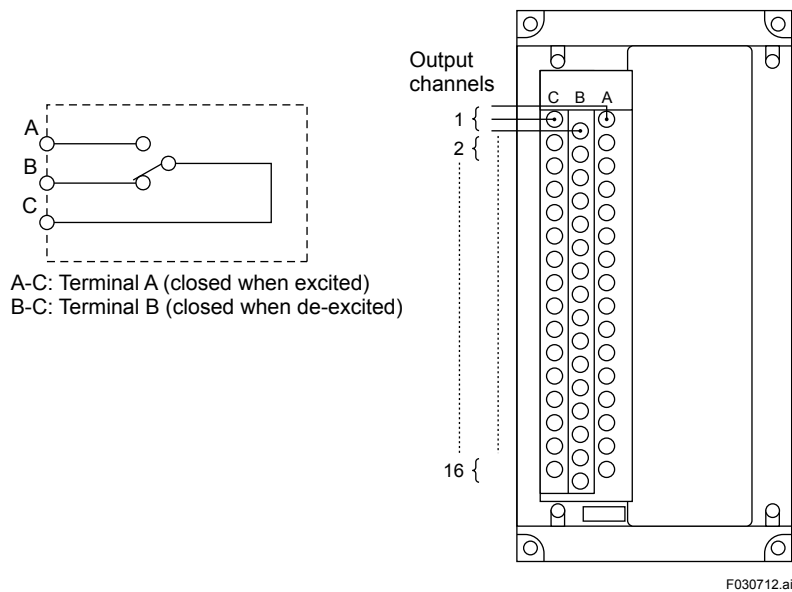

Figure Signal Cable Connection of Relay Output Module ADM55R

3.7.6 Connecting Signal Cables with Multiplexer Modules (Terminal Type)

Voltage Input, mV Input, Thermocouple Input, 2-wire Transmitter Input, Current Output Modules AMM12T, AMM22M, AMM22T, AMM22TJ, AMM42T, AMM52T.

Only one AMM42T or AMM52T can be installed in one nest.

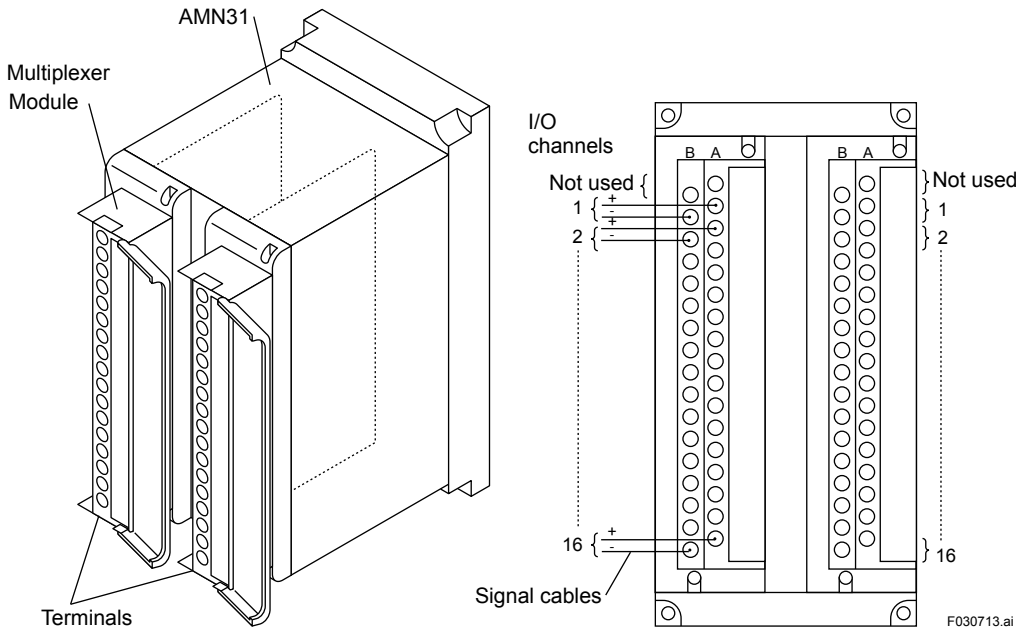

Figure Multiplexer Module Signal Cable Connection

RTD Input Modules AMM32T, AMM32TJ

Only one AMM32T or AMM32TJ can be installed in one nest.

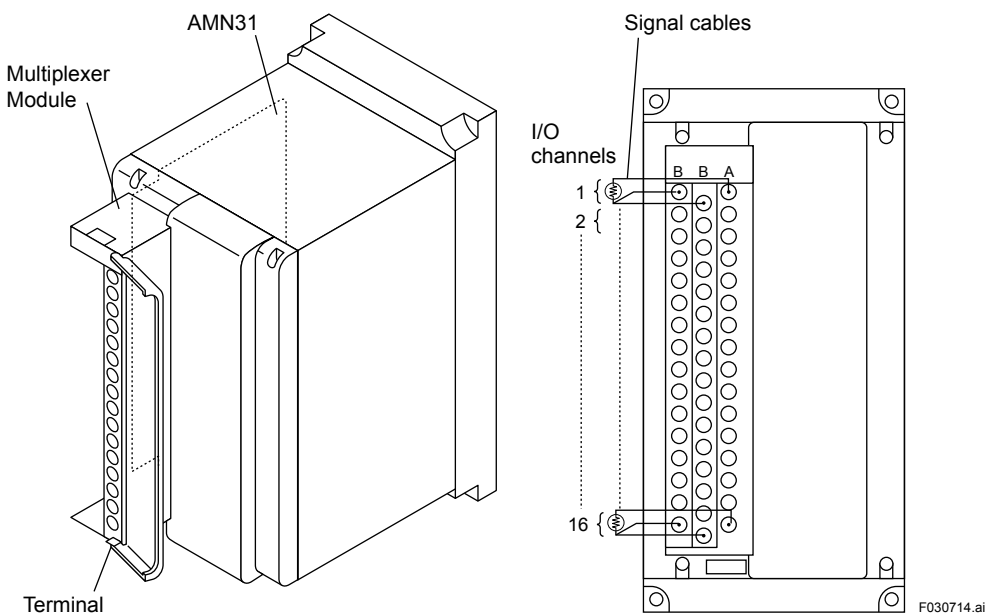

Figure Signal Cable Connection of RTD Input Multiplexer Modules AAM32T, AAM32TJ

3.7.7 Connecting Signal Cables with Multiplexer Modules (Connector Type)

Multiplexer Modules (Connector Type) AMM12C, AMM22C, AMM25C, AMM32C, AMM32CJ

Connect the shield of the Yokogawa-specific cable to each screw-mount shield terminal.

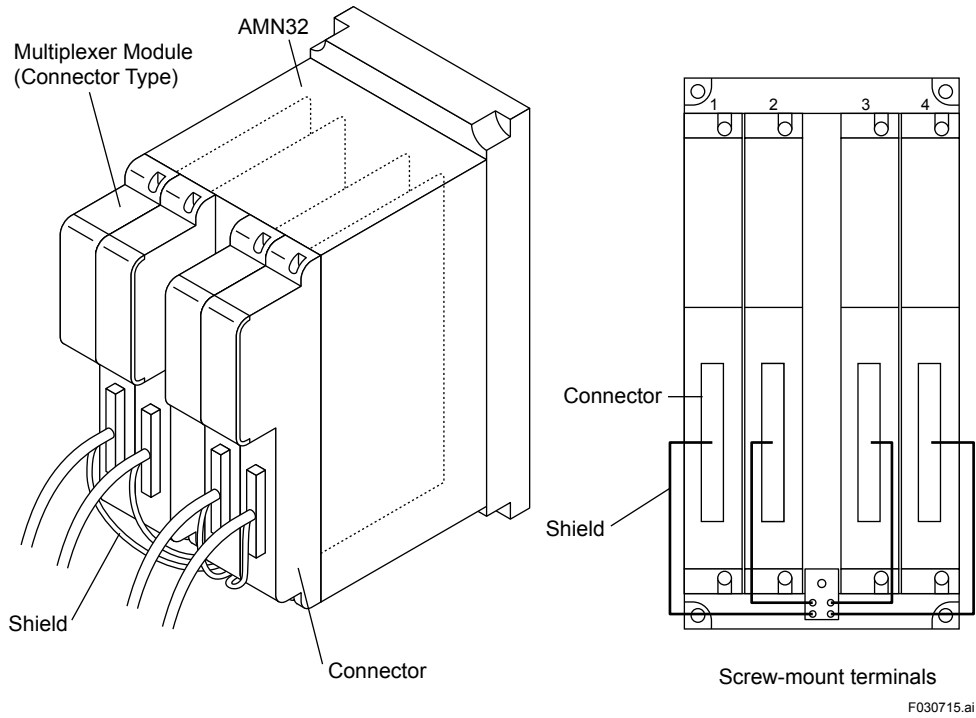

Figure Multiplexer Module (Connector Type) Signal Cable Connection

Connector Type Multiplexer Module and Terminal Board/Terminal Block

Connect a multiplexer module to a terminal board/terminal block as described in the table below.

Table Connecting a Multiplexer Module and Terminal Board/Terminal Block

Multiplexer Module (Connector Type)	Terminal Board	Terminal Block	Cable
AMM12C	MUB	TE16	KS2
AMM22C	MUB	TE16	KS2
AMM25C	MTC	TETC	KS1
AMM32C, AMM32CJ	MRT	TERT	KS8

3.7.8 Connecting Signal Cables with Digital I/O Modules (Terminal Type)

16-Point Digital I/O Modules ADM11T, ADM51T

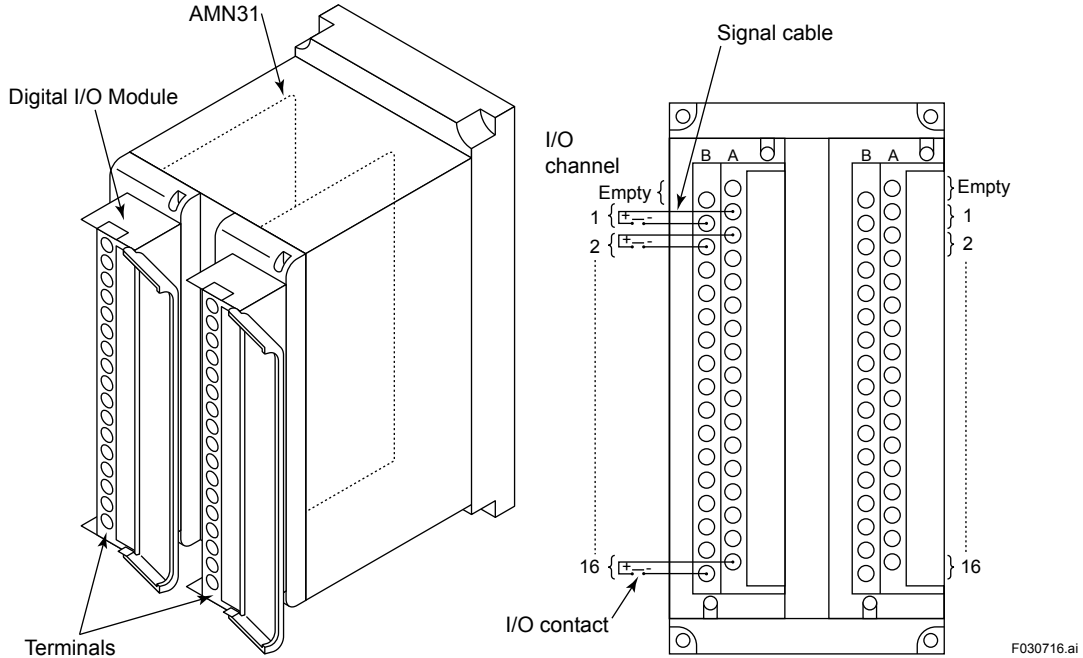

Figure 16-Point Digital I/O Module Signal Cable Connection

32-Point Digital I/O Modules ADM12T, ADM52T

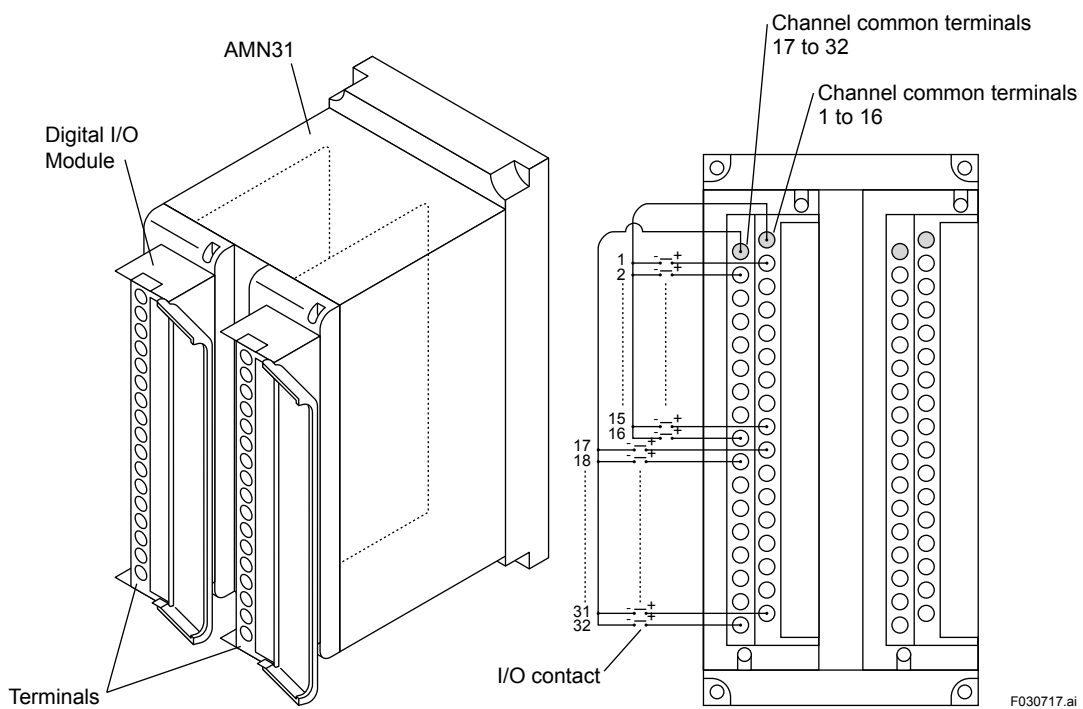

Figure 32-Point Digital I/O Module Signal Cable Connection

3.7.9 Connecting Signal Cables with Digital I/O Modules (Connector Type)

Digital I/O Modules ADM11C, ADM12C, ADM51C, ADM52C

Connect the shield of the Yokogawa-specific cable to each screw-mount shield terminal.

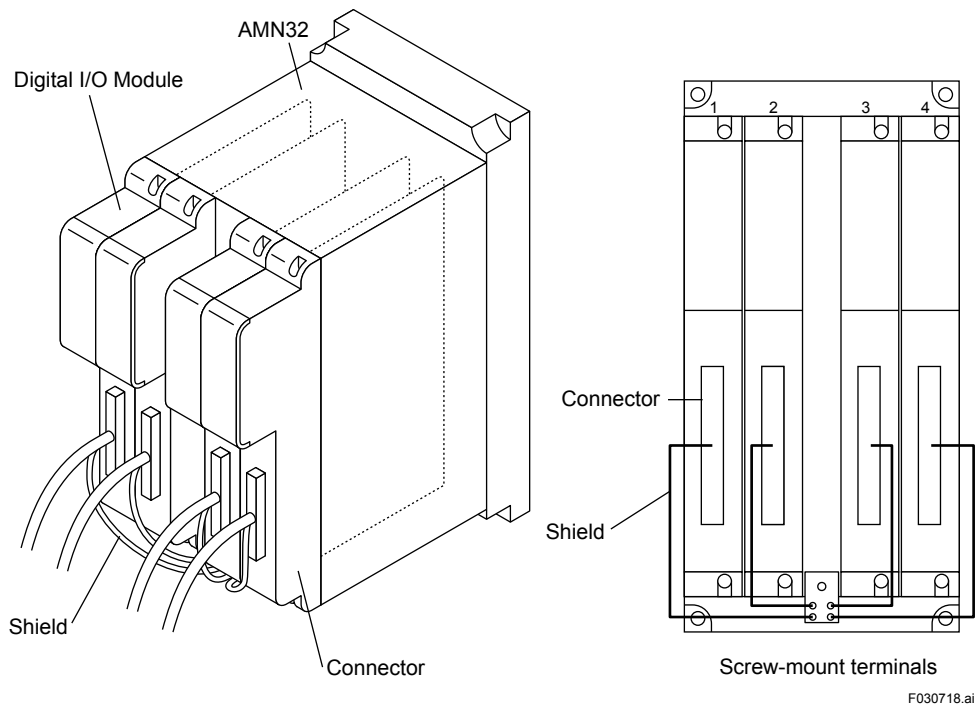

Figure Connector-type Digital I/O Module Signal Cable Connection

F030718.ai

3.7.10 Connecting Signal Cables with Communication Modules

RS-232C Communication Module ACM11

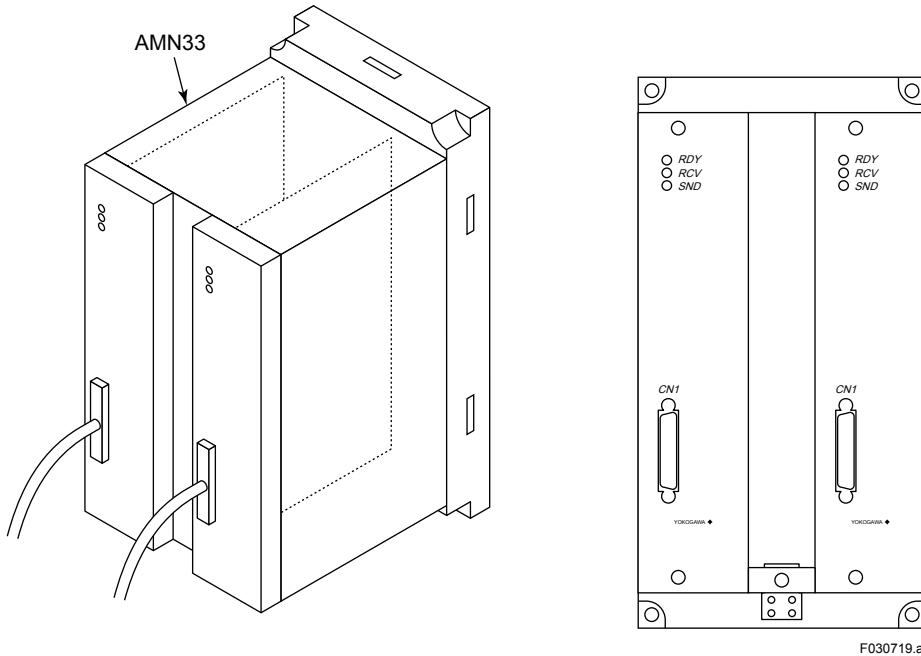

Figure ACM11 Signal Cable Connection

Use modem cable KB3 and null modem cable KB4 with a D-sub 25-pin connector.

Table RS-232C Interface Connector Pin Positions

Pin position	Code	Signal	Description
1	FG	Frame Ground	Maintenance grounding
2	SD	Send Data	Transmission data (output)
3	RD	Receive Data	Receiving data (input)
4	RS	Request to Send	Transmission request (output)
5	CS	Clear to Send	Ready for transmission (input)
6	DR	Dataset Ready	Dataset ready (input)
7	SG	Signal Ground	Signal common return
8	CD	Carrier Detect	Carrier detection (input)
20	ER	Equipment Ready	Data terminal ready (output)



IMPORTANT

When the system is used in Europe, attach a clamp filter (ferrite core) complying with the EMC standard in order to use RS-232C.

The parts number of the clamp filter is A1179MN.

Mounting Clamp Filter (Ferrite Core) (for European Market)

When the system is used in Europe, attach a clamp filter (ferrite core) complying with the EMC standard in order to use RS-232C.

Mounting Clamp Filter (Ferrite Core)

After completing the RS-232C cabling, mount the supplied clamp filter on the covering of the RS-232C cable to provide enhanced immunity to noise.

Clamp Filter Parts

Core (Part number: A1179MN with cable fastener)

The inside diameter of the core is 13 ± 1 mm.

Clamp Filter Location

When installing a core, leave about 8 cm between the surface of the ACM11 module and the core.

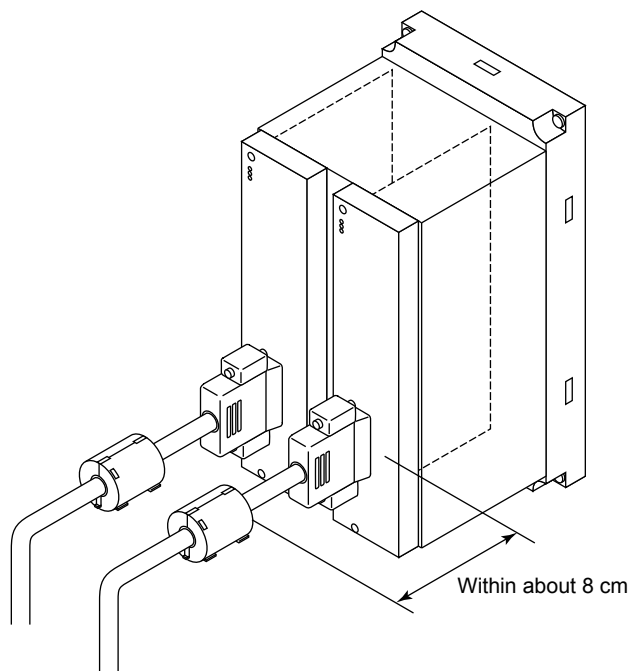

F030720.ai

Figure Mounting Clamp Filters

Structure of Clamp Filter and Mounting

1. Unlock the two core lock claws by hand, and the core will open about 150° and split into two pieces as shown in the figure below.

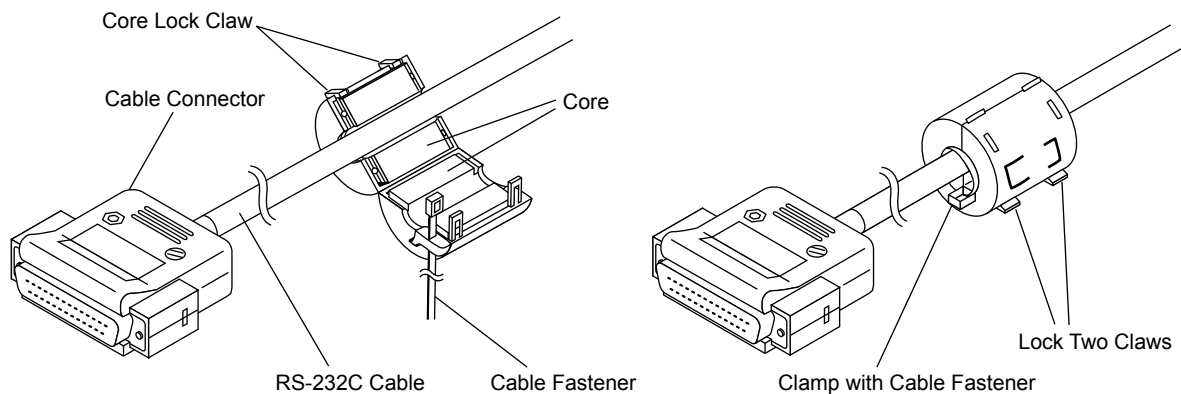

F030721.ai

Figure Structure of Clamp Filter and Mounting

2. Put the RS-232C cable into the cylindrical part of the opened core.
3. Close the core with the RS-232C cable within it, and lock the clamp filter with two core lock claws.
4. Pass a cable fastener into either hole in the clamp filter and secure the RS-232C cable by clamping the cable fastener over the cable coating.



IMPORTANT

The clamp filter consists of a ferrite core. Avoid mechanical shocks to it such as by dropping it, and keep it within the temperature ranges during operation and storage.

RS-422/RS-485 Communication Module ACM12

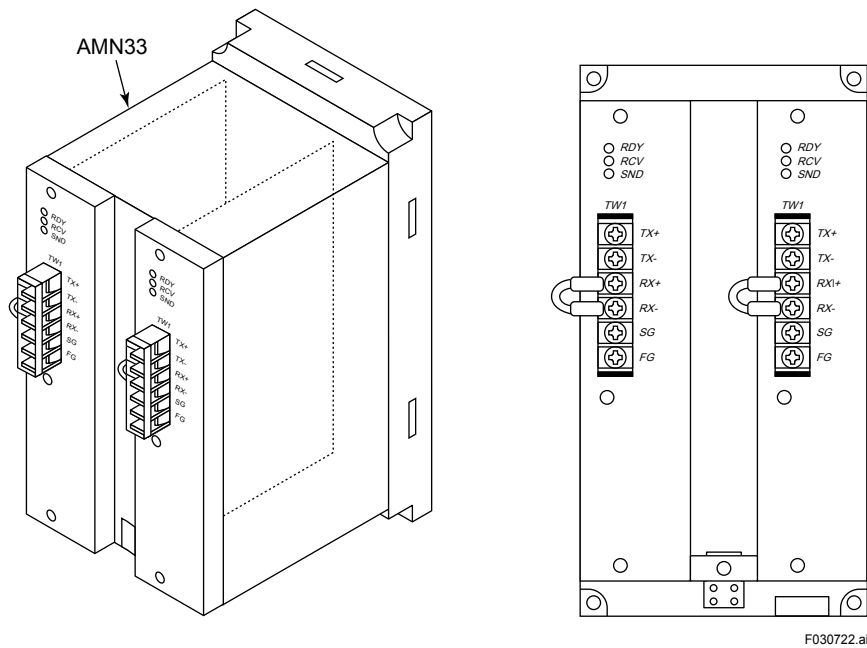

Figure ACM12 Signal Cable Connection

Table RS-422/RS-485 Interface Terminal Positions

Terminal Code	Signal Name	Description
TX+	Send Data	Transmission data (in-phase signals)
TX-	Send Data	Transmission data (phase-reversal signals)
RX+	Receive Data	Receiving data (in-phase signals)
RX-	Receive Data	Receiving data (phase-reversal signals)
SG	Signal Ground	Signal grounding
FG	Frame Ground	Protective grounding

RS-232C Communication Card ACM21

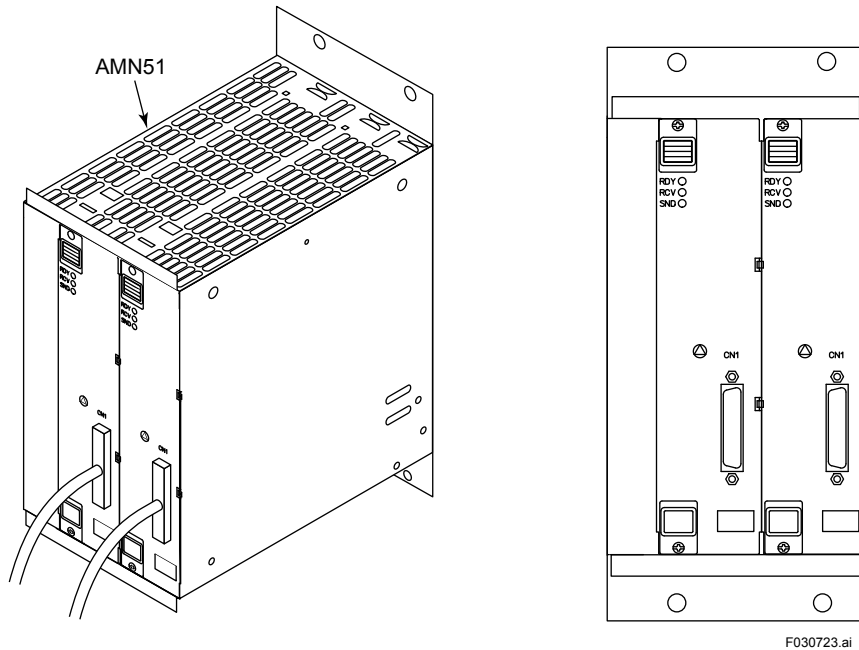

Figure ACM21 Signal Cable Connection

Use modem cable KB3 and null modem cable KB4 with a D-Sub 25-pin connector.

Table RS-232C Interface Connector Pin Positions

Pin Assign	Signal Abbreviation	Signal Name	Description
1	FG	Frame Ground	Maintenance grounding
2	SD	Send Data (output)	Transmission data (output)
3	RD	Receive Data	Receiving data (input)
4	RS	Request to Send (output)	Transmission request (output)
5	CS	Clear to Send	Ready for transmission (input)
6	DR	Dataset Ready (input)	Dataset ready (input)
7	SG	Signal Ground	Signal common return
8	CD	Carrier Detect (input)	Carrier detection (input)
20	ER	Equipment Ready (output)	Data terminal ready (output)

RS-422/RS-485 Communication Card ACM22

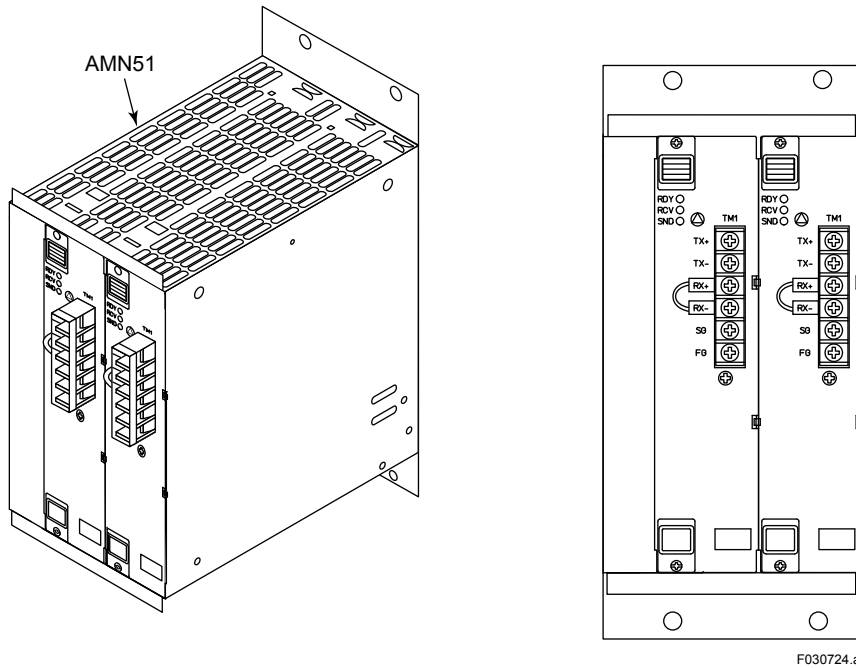

F030724.ai

Figure ACM22 Signal Cable Connection

Table RS-422/RS-485 Interface Terminal Positions

Terminal Code	Signal Name	Description
TX+	Send Data	Transmission data (in-phase signals)
TX-	Send Data	Transmission data (phase-reversal signals)
RX+	Receive Data	Receiving data (in-phase signals)
RX-	Receive Data	Receiving data (phase-reversal signals)
SG	Signal Ground	Signal grounding
FG	Frame Ground	Protective grounding

Ethernet Communication Module ACM71 (For PFC□)

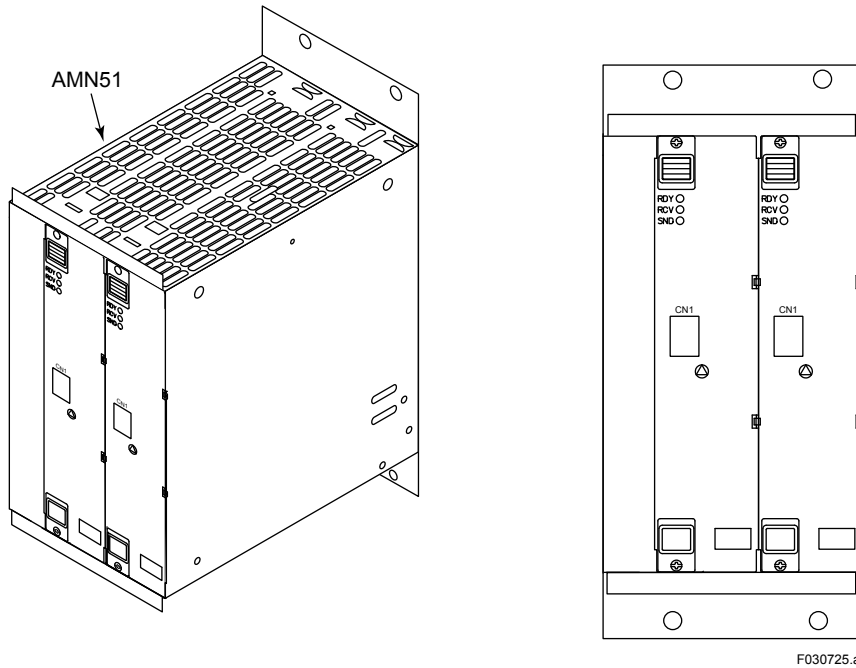

Figure Ethernet Communication Module ACM71

Use 10BASE-T, non-shielded, 100-ohm twisted-pair cables for Ethernet connections.

Table Pin Assignment of Ethernet Interface Connector (RJ-45)

Pin	Signal Abbreviation	Signal Name
1	TD+	Send Data (+)
2	TD-	Send Data (-)
3	RD+	Receive Data (+)
4	—	—
5	—	—
6	RD-	Receive Data (-)
7	—	—
8	—	—

3.7.11 Connecting the Fieldbus Cable and Handling the Shield Mesh for Fieldbus Communication Module ACF11

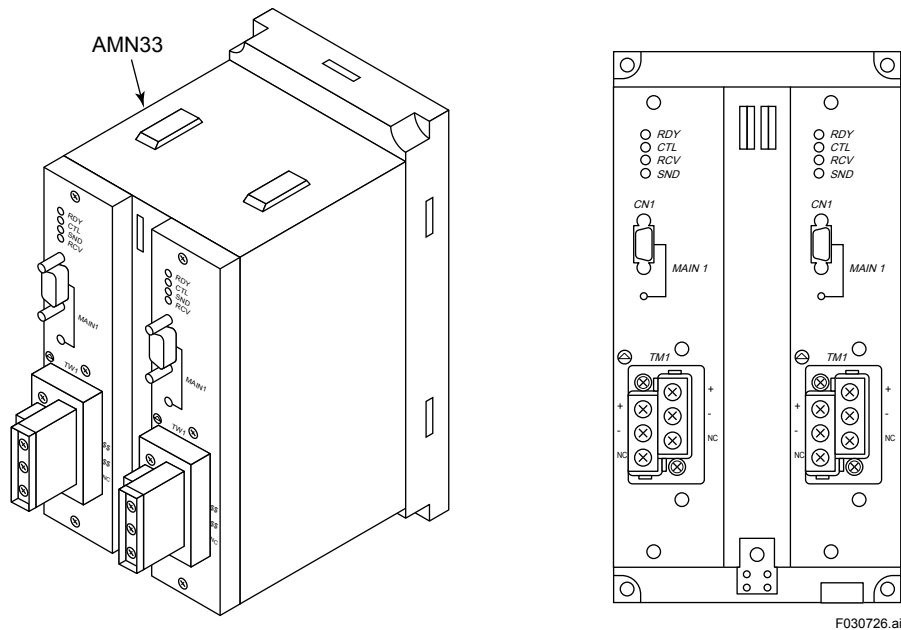

Figure ACF11 Signal Wiring Terminals

Connect field signals to the + and - signal terminals (marked 1 and 2 respectively).

A clamp filter must be attached to the signal cable as shown.

Connect a terminator to terminals 4 and 5.

Do not connect anything to terminals marked NC (No Connection), i.e. terminals 3 and 6.

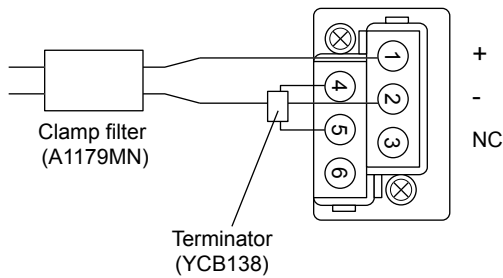

Figure ACF11 Signal Wiring Terminals

SEE ALSO

- For details of Fieldbus connection and wiring work, refer to “Fieldbus Technical Information” (TI 38K03A01-01E).
- The clamp filter part number and method of attachment are the same as for that used in the ACM11 Communications Module. Mount it as close as possible to the terminals, as illustrated in the figure below.

There is a gap between the inside of the core and outside of the cable, so secure the cable by clamping the cable fastener over the cable coating.

Use a Type A cable for the connection between the ACF11 and the marshalling rack (shown in dotted box in the figure below), in which the shield of the cable from the field is connected to the ground terminal.

Connect the shield of the Type A cable of the FCU side (inside the cabinet) to the cabinet internal ground bar. If it is necessary to separate the shield ground from the other ground, disconnect the wire between the cabinet internal shield ground bar and FCU ground bar, and ground them separately.

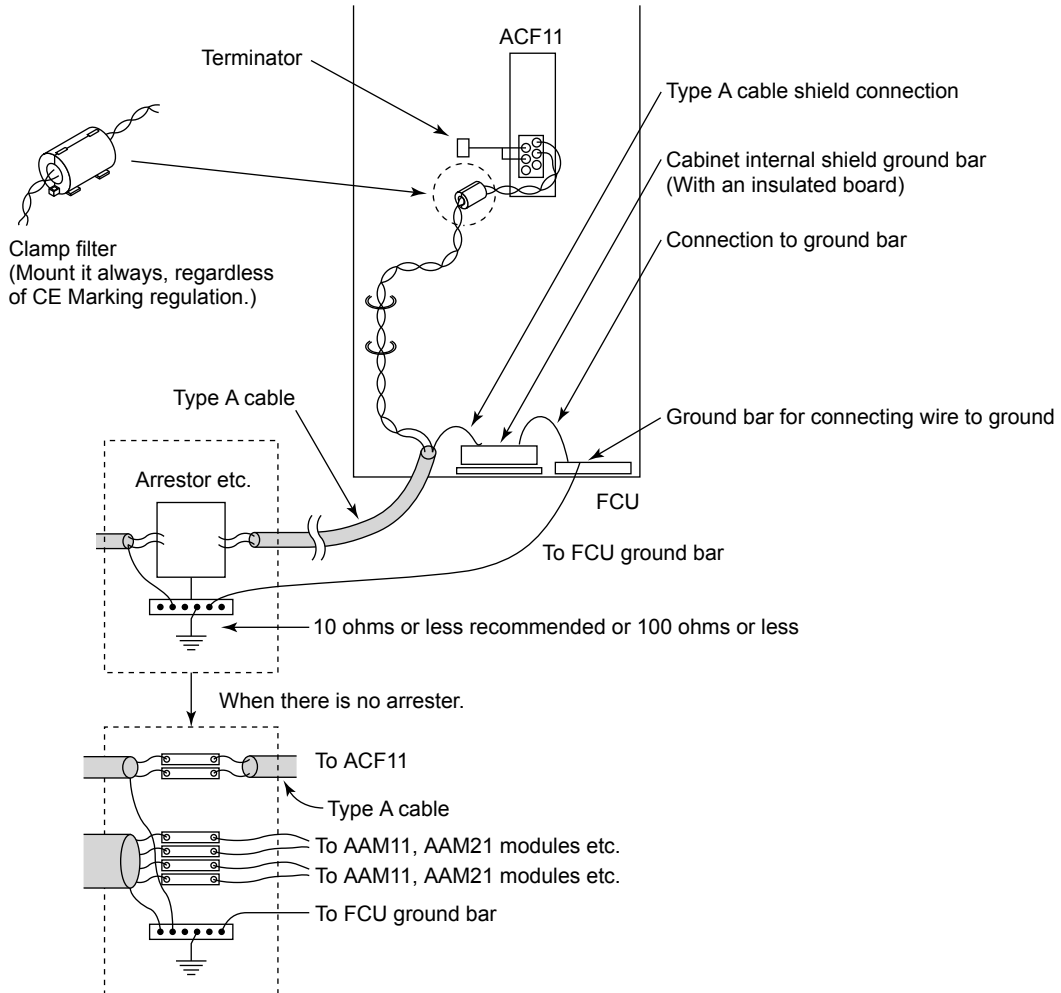

F030728.ai

Figure Connecting Fieldbus Cable with Fieldbus Communication Module ACF11

3.7.12 Connecting Signal Cables with PROFIBUS Communication Module ACP71

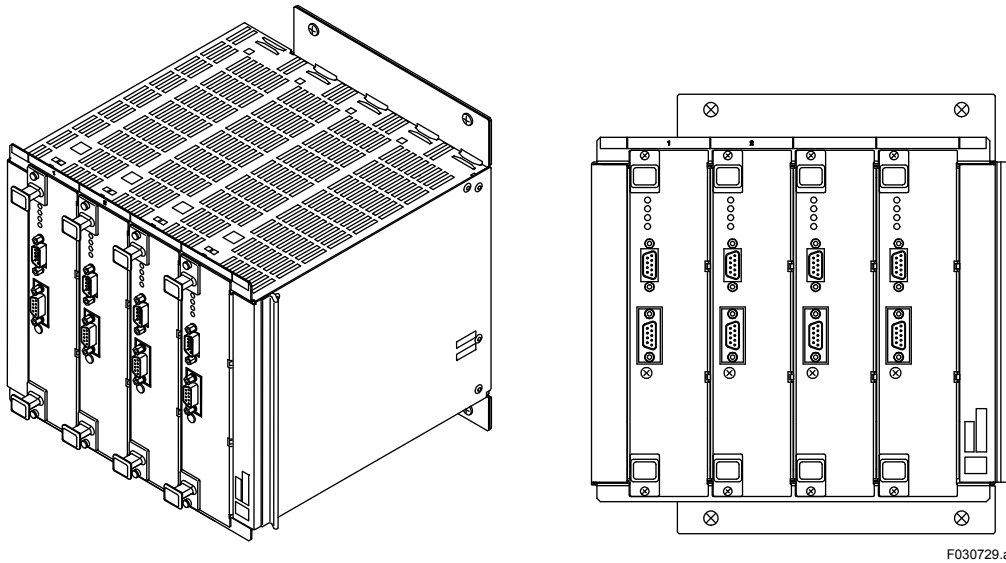

Figure PROFIBUS Communication Module ACP71

Use shielded twisted-pair cables for PROFIBUS.

Table PROFIBUS Interface Connector Pin Positions

Pin position	Signal	Description
1	Shield	
2	N.C.	
3	A-Line	I/O data
4	CNTR-P	Repeater Control Signal
5	D-GND	
6	VP	+5V
7	N.C.	
8	B-Line	I/O data
9	N.C.	

3.8 Connecting Bus Cable



IMPORTANT

1. When the sheath of the control-bus cable is connected, there is a possibility that (ground loop) currents will flow in the sheath.
 2. Before connecting a V net splitter (N-type or BNC-type) to coaxial cable, use the following method to drain static electricity: wear a wrist strap. If the cable is already connected to other stations, this is not necessary.
 - Momentarily short the cable inner conductor to the outer sheath.
 - Next connect the cable to the coupler.
-

V net

The following is an example of connecting a control bus.

- Attach a T-shaped plug to the BUS1 and BUS2 BNC connectors of the control bus interface card. Order the T-shaped plug separately.
- Connect V net cables (10BASE-2 cable: YCB141) to the BUS1 and BUS2 through previous station.
- Connect V net cables (10BASE-2) from the other side of the T-shaped plug to next station.
- When connecting V net cable (10BASE-5 cable: YCB111) to next station, place a connection unit (YCB147) between V net cable (YCB141) and V net cable (YCB111). Order a connection unit separately.
- When no next station is connected, attach YCB148 V net Terminator for 10BASE-2 cable and YCB118 for 10BASE-5 cable.



IMPORTANT

In this document, 10BASE-5 and 10BASE-2, terminology of Ethernet, are use to describe the V net cables for easier understanding. Actually, V net is different from Ethernet. Yokogawa's YCB111 and YCB141 cables should be used instead of 10BASE-5 and 10BASE-2 cables.

Connecting V net cables (10BASE-2)

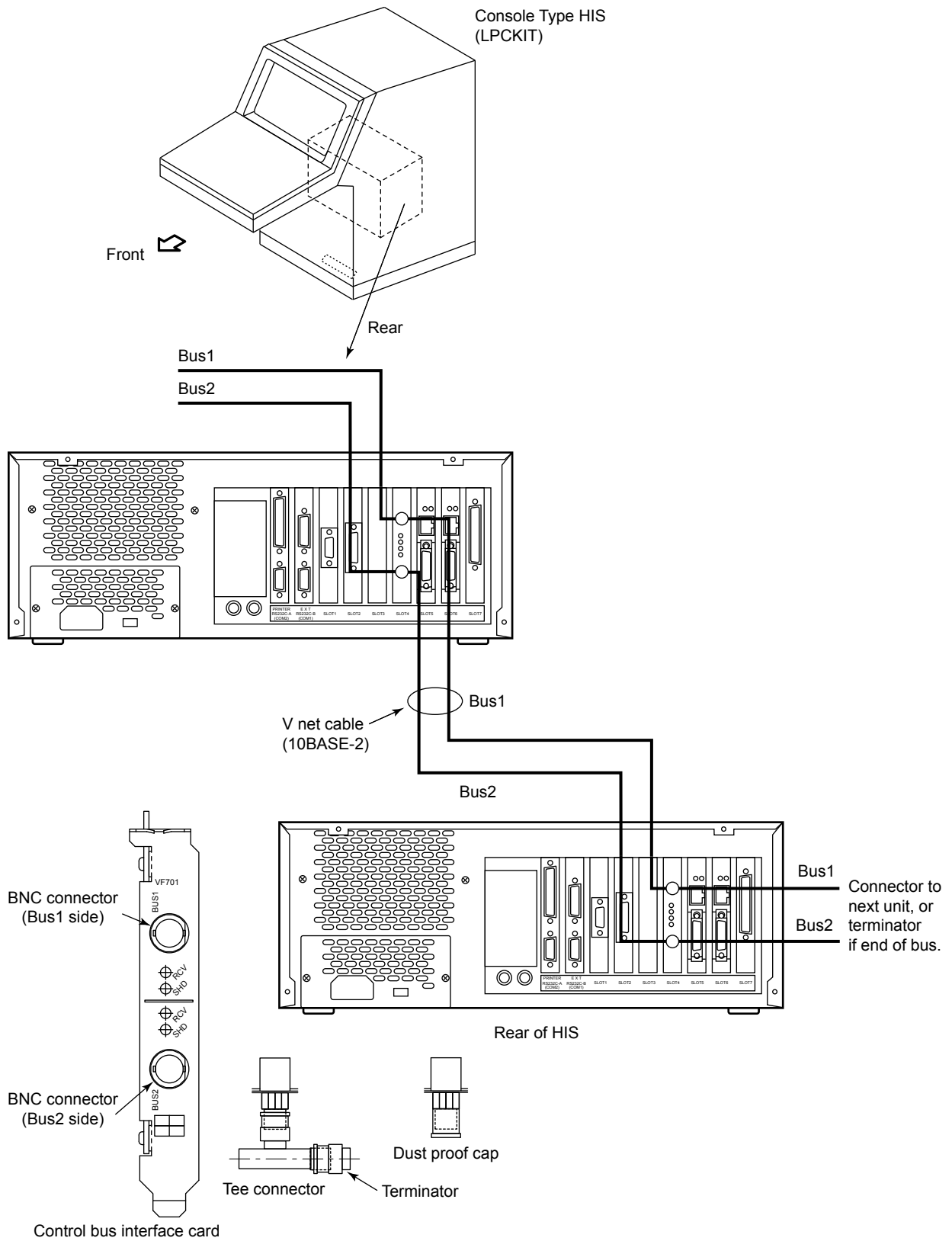

Figure V net Cable (10BASE-2) Connection

F030801.ai

**Connecting V net cables (10BASE-5) and V net cables (10BASE-2)
Interconnection Example**

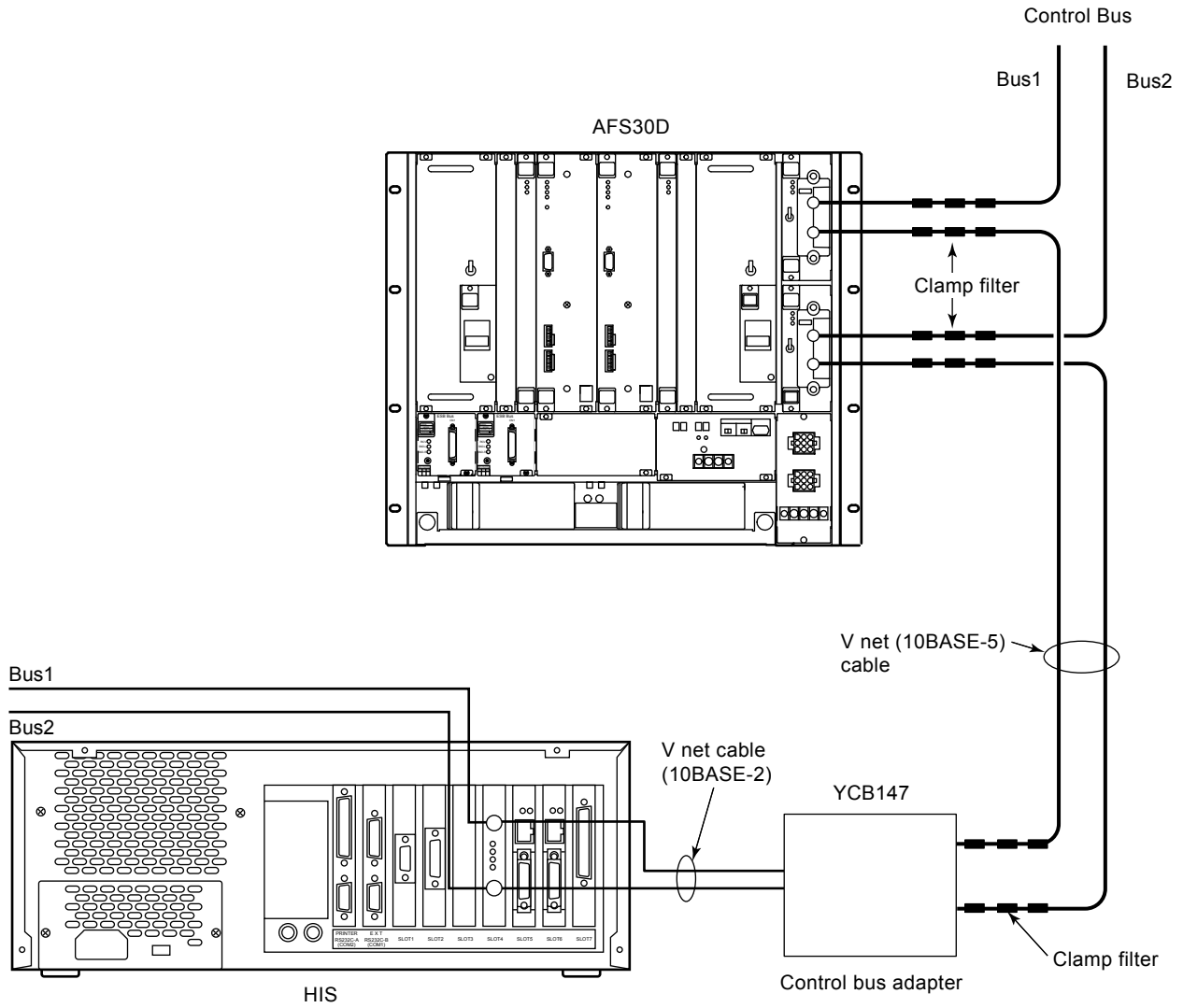

Figure V net Cable (10BASE-2 and 10BASE-5) Connection

F030802.ai

Control Bus Adapter

For control buses for the Human Interface Station (HIS) and Compact Field Control Stations for FIO (AFF50S/AFF50D), use V net (10BASE-2) cables. For control buses for field control stations other than the Compact Field Control Stations for FIO, use V net (10BASE-5) cables. The cable conversion adapter is required to connect these two types of cable, which are of different diameters.

The figure below shows how 10BASE-5 cable and 10BASE-2 cable are connected.

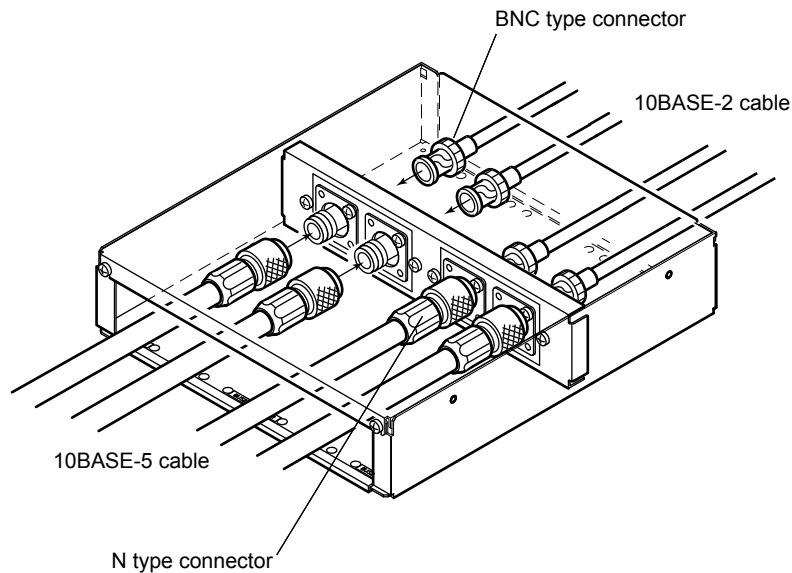

F030803.ai

Figure Control Bus Adapter (YCB147)

The thickness and weight of the two types of cable are different; the control bus adapter (rack mountable type shown above) used to connect them.

- The V net cable (10BASE-2) is low less, so mount the adapter so as to minimize the length of 10BASE-2 (which is more lossy).
- For ease of maintenance, mount the adapter above floor and near the HIS.
- Do not mount the adapter in a passageway or aisle between equipment.
- The rack mountable type illustrated above can be mounted in a rack or console.

Connecting V net cables (10BASE-5)

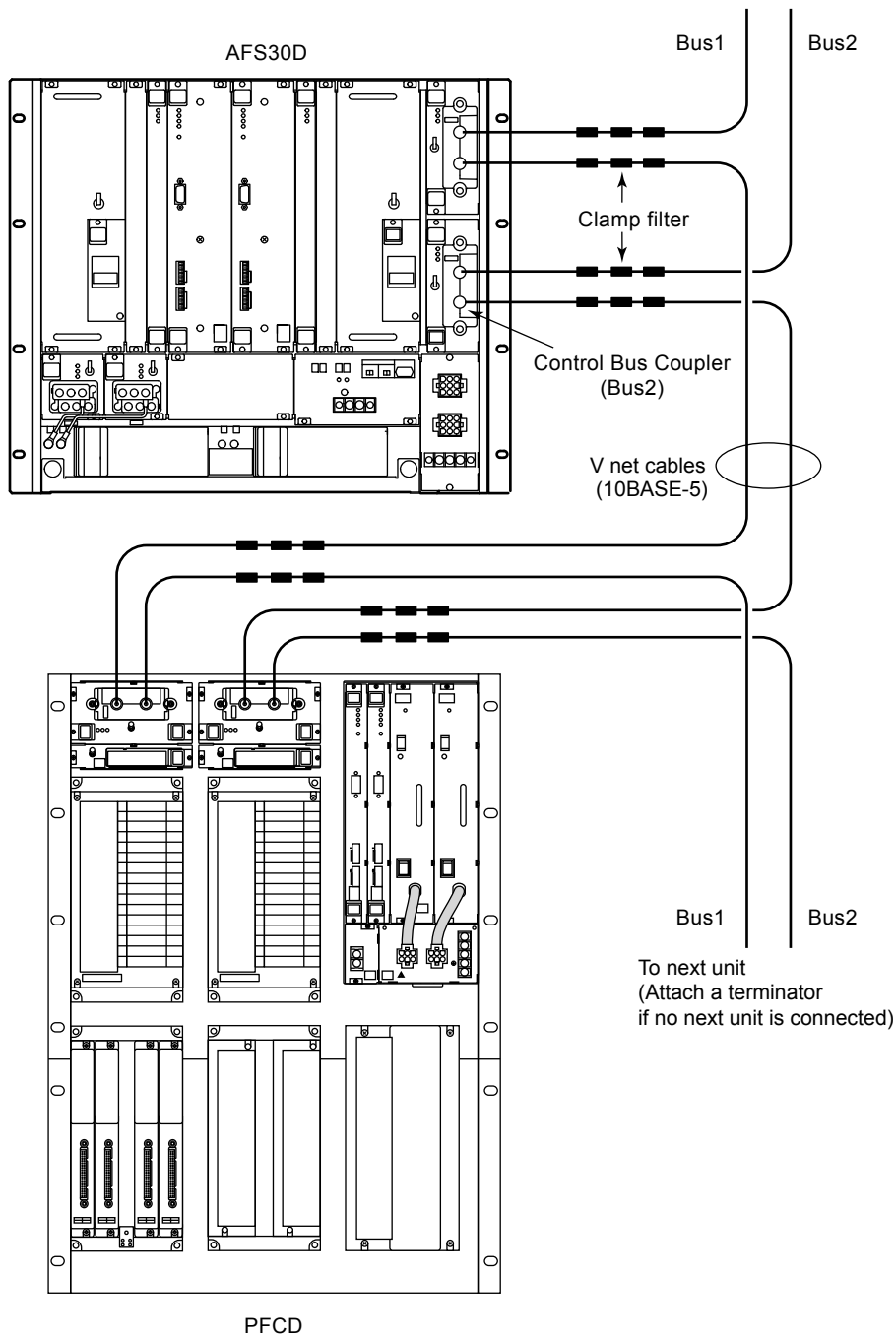

Figure V net Cable (10BASE-5) Connection

F030804.ai

V net Coupler Installation (ACG10S)

The V net couplers of desktop communication gateway can be attached in three ways depending on where bracket is installed, as shown below:

- Rack Mounting

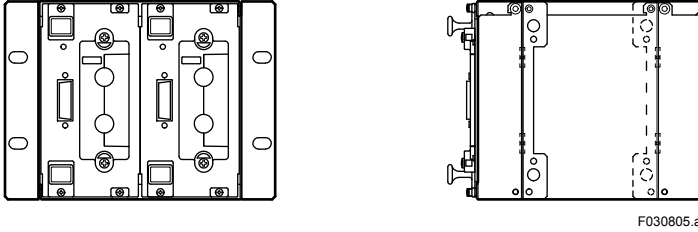

- Horizontal Side Mounting

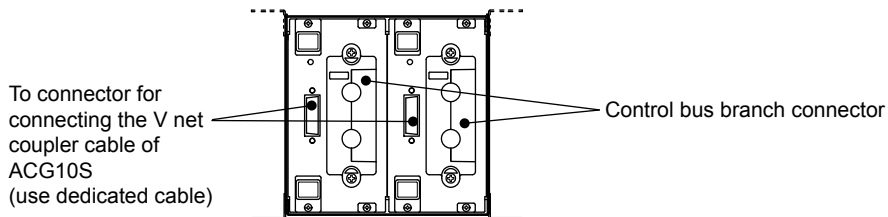
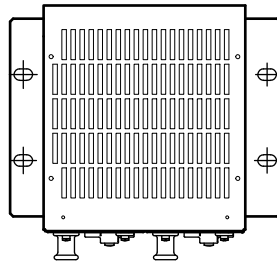

F030806.ai

- Vertical Side Mounting

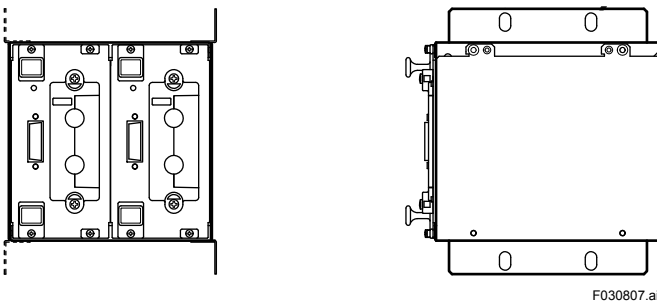
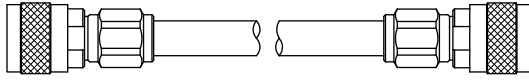

Figure Mounting the V net Coupler

V net cable (10BASE-5)

- V net cable (10BASE-5)



Connection: Type N plug
Finished cable dimensions: $\varnothing 10.3$ mm

- V net terminator (for 10BASE-5 cable)

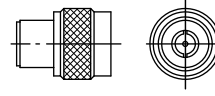

Connection: Type N plug
Impedance: 50 ohm

F030808.ai

Figure V net cable and V net terminator (for 10BASE-5 cable)

- V net grounding unit

When you use a V net cable for extension, use the YCB117 V net Grounding Unit. The unit is used to ground V net-connected devices at one point for safety. Ground each bus in a segment at one point (In a segment, devices can communicate on the same bus without repeater).

Place the unit on the bottom of an FCU cabinet or the like. You do not need to secure it. Connect a grounding cable to a grounding bar (100 ohms or less) of an FCU cabinet or the like, as shown below.

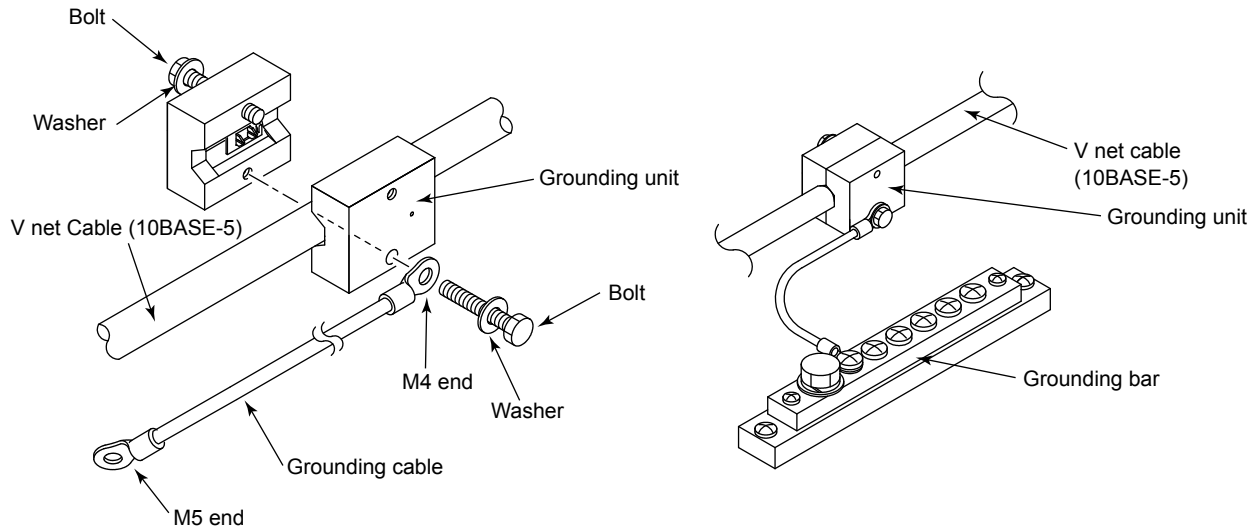

F030809.ai

Figure Assembly of V net Grounding Unit and Its Use

- **Clamp filter**
In order to enhance noise resistance, attach three clamp filters in succession at both ends of the V net cable (10BASE-5) near to the V net couplers. Refer to Figure for a typical mounting example.

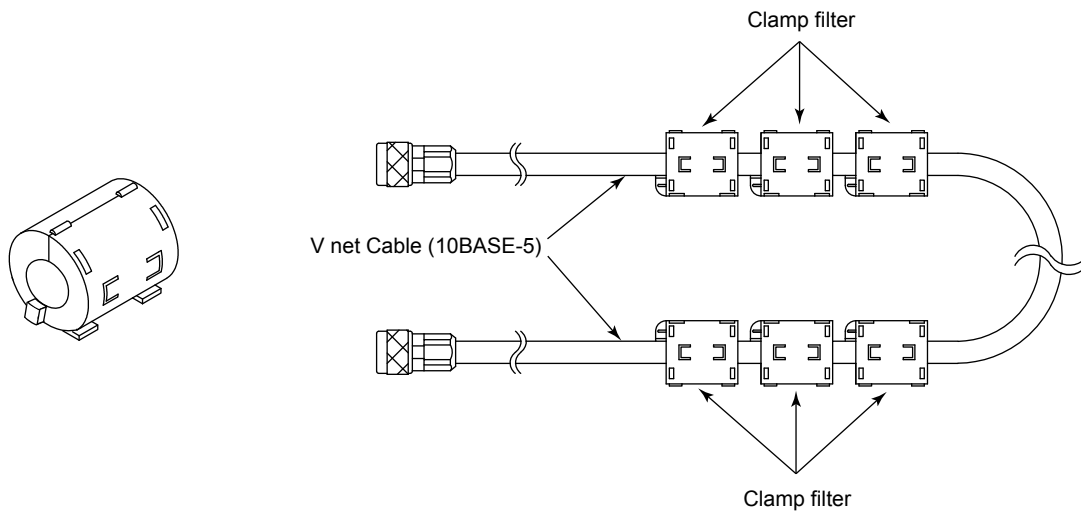

F030810.ai

Figure Clamp filter

V net cable (10BASE-2)

- V net cable (10BASE-2)

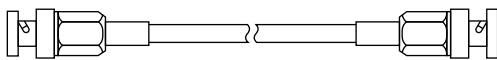

Connection: Type BNC plug
Finished cable dimensions: $\varnothing 5$ mm

- V net terminator (for 10BASE-2 cable)

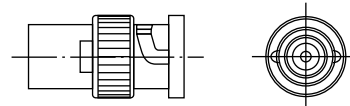

Connection: Type BNC plug
Impedance: 50 ohm

F030820.ai

Figure V net cable and V net terminator (for 10BASE-2 cable)

- **T-type connector**

When the V net cable is connected, put the T-type connector between insulation sheets to prevent it from touching other metals. The surfaces of the insulation sheets that come with the T-type connector (2 sheets) are adhesive. The figure below shows how to attach them. Place two pieces of insulation sheets so that the adhesive surfaces face the T-type connector and sandwich the T-type connector between them.

Press the two pieces of insulation sheets together tightly with your fingers, making sure that the sheets cover the metal part of the T-type connector.

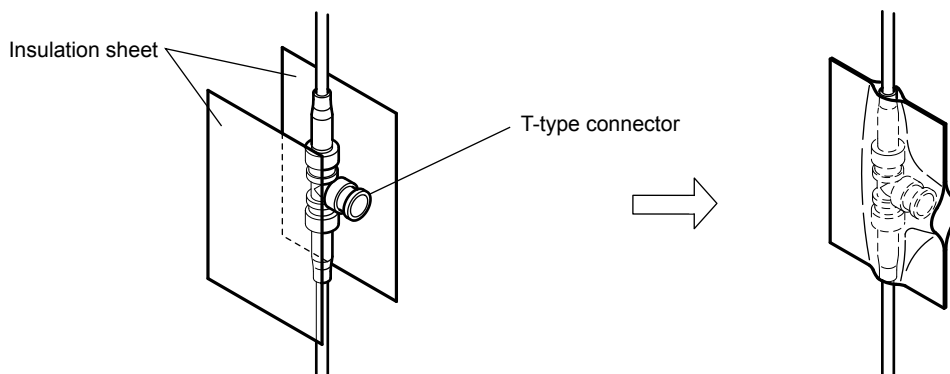

F030819.ai

Figure Insulation Sheet

- **BNC Connector Cover**
If V net (10BASE-2) cables are connected to the AFF50□, install BNC connector covers to prevent the BNC connectors from coming into contact with other pieces of metal. Four BNC connector covers are supplied with the AFF50□.

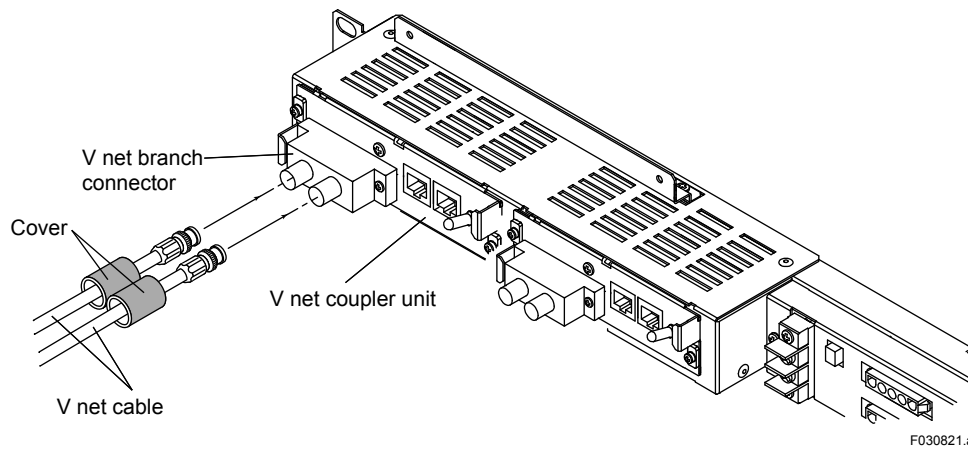
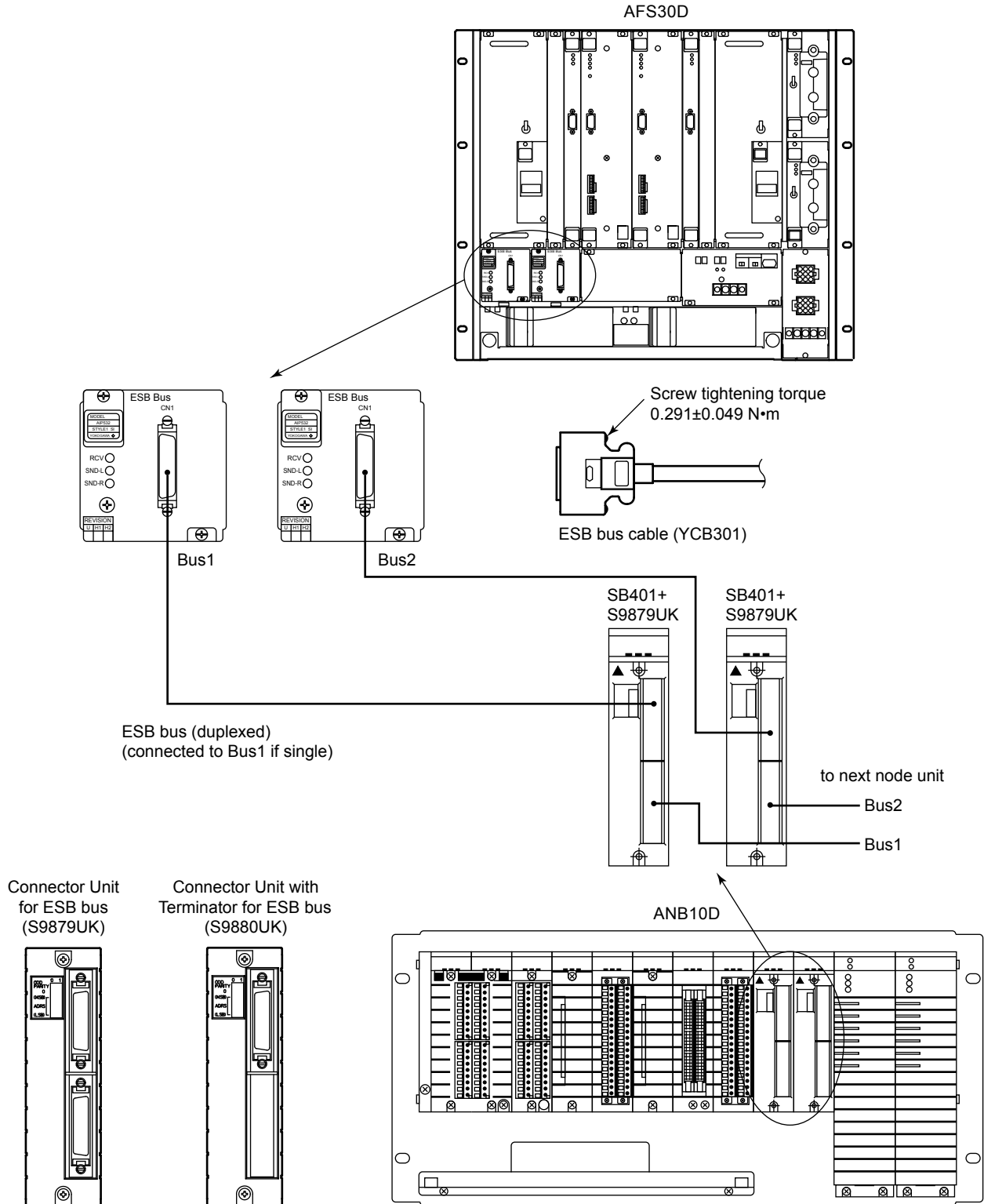

Figure BNC Connector Cover

ESB Bus

The following is an example of connecting an ESB bus.
 Either ESB bus branching connector or the branching connector that has a built-in ESB bus terminator must be mounted to SB401 installed in ESB bus node unit. If a node unit is connected next, select ESB bus branching connector. If the node unit is the last one, select the branching connector that has a built-in ESB bus terminator.



F030811.ai

Figure ESB bus Connection (AFS30D)

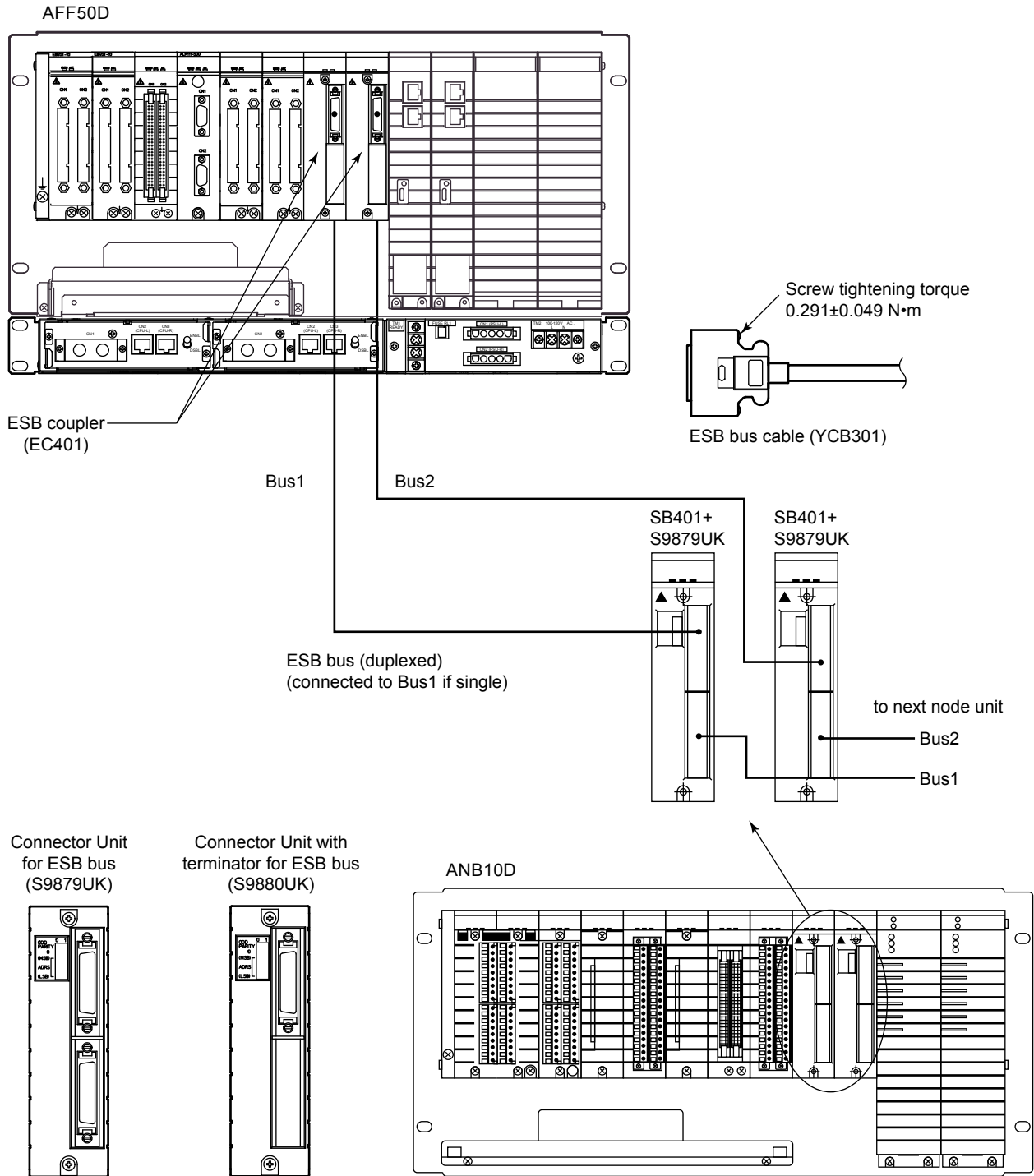

Figure ESB bus Connection (AFF50D)

F030822.ai

ER Bus

The following is an example of connecting an ER bus.

If no next station is connected, attach YCB148 Terminator.

Avoid using ER bus cable with other cables and also avoid wiring its cable in parallel with others.

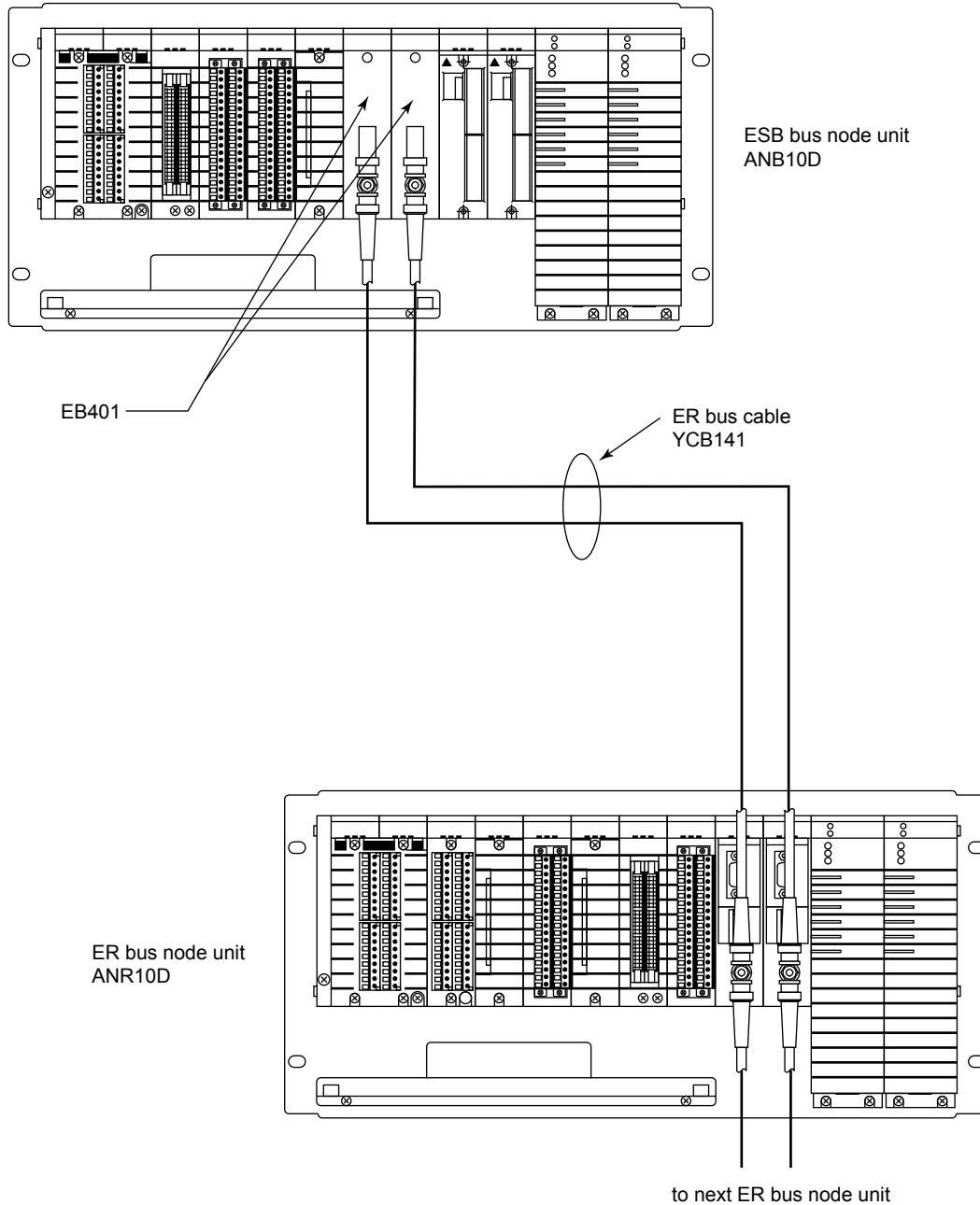

F030812.ai

Figure ER bus Connection (19-inch Rack Mountable Type)

How to wiring ER bus

The figure shown below describes how to wiring ER bus:

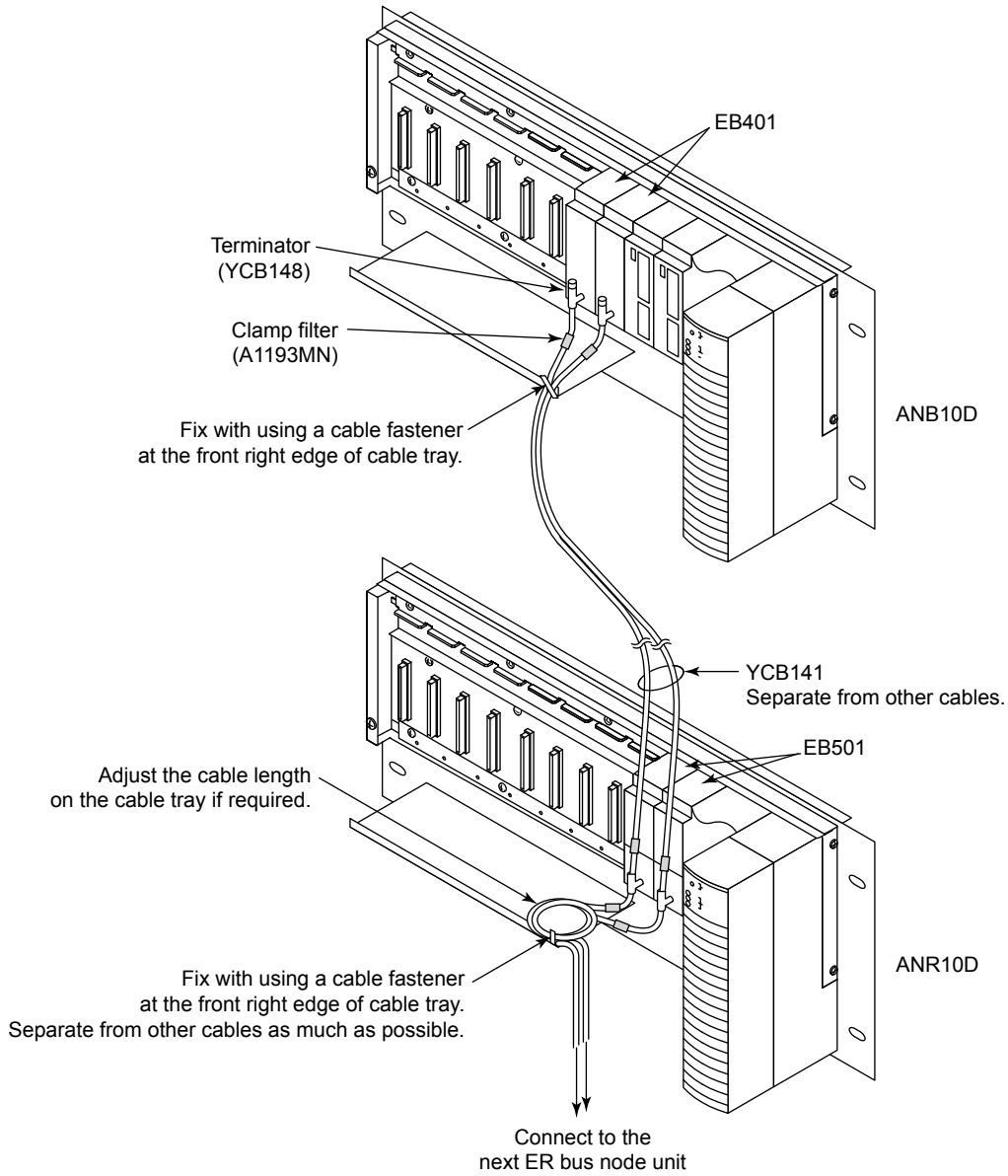

F030813.ai

Figure How to wiring ER bus

Terminator

Regarding EB401 and EB501, if one side of T-type connector is terminal, mount a terminator. Two terminators are supplied with EB401.

Clamp Filter

Regarding EB401 and EB501, mount clamp filters to both side of T-type connector. If one of the sides is terminal, mount a clamp filter to only the cable side. Two (four for dual-redundant) clamp filters are supplied with the remote node. For EB401, use the clamp filter supplied with the terminal remote node.

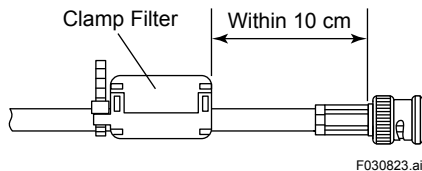

Figure Clamp Filter

T-type connector

When the ER bus cable is connected, put the T-type connector between insulation sheets to prevent it from touching other metals. The surfaces of the insulation sheets that come with the T-type connector (2 sheets) are adhesive. The figure below shows how to attach them.

Place two pieces of insulation sheets so that the adhesive surfaces face the T-type connector and sandwich the T-type connector between them.

Press the two pieces of insulation sheets together tightly with your fingers, making sure that the sheets cover the metal part of the T-type connector.

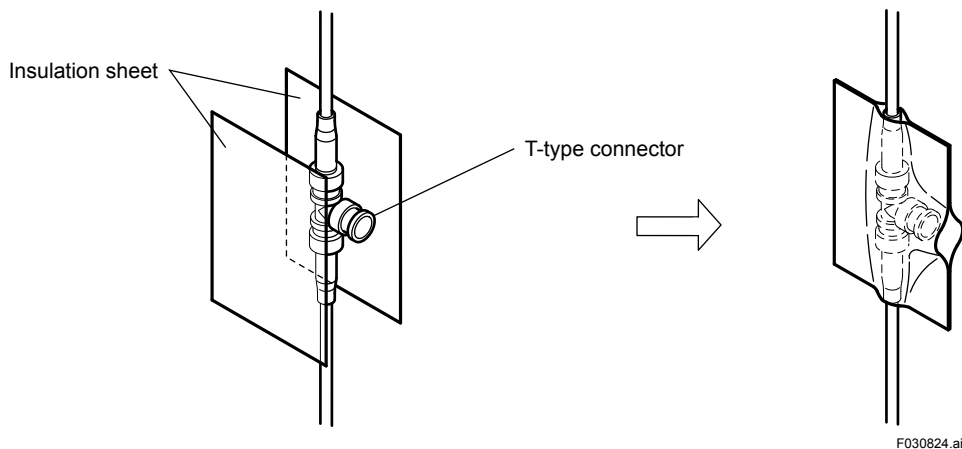

Figure Insulation Sheet

ER Bus Converting Adapter

The converting adapter is required when connecting 10BASE-2 and 10BASE-5 cable.

SEE ALSO For more information about the converting adapter, see the following:
“● Control Bus Adapter” in “3.8 Connecting Bus Cable”

10BASE-5 Cable

When 10BASE-5 cable is used, a grounding unit (YCB117) should be used for grounding. For one segment (a communication range of bus connection that no repeater is used), one point per bus needs to be grounded.

SEE ALSO For more information about the grounding unit, see the following:
“● V net cable (10BASE-5)” in “3.8 Connecting Bus Cable”

RIO Bus

The following is an example of connecting an RIO bus.
If no next station is connected, attach YCB128 Terminator.

RIO Bus (19-inch Rack Mountable Type)

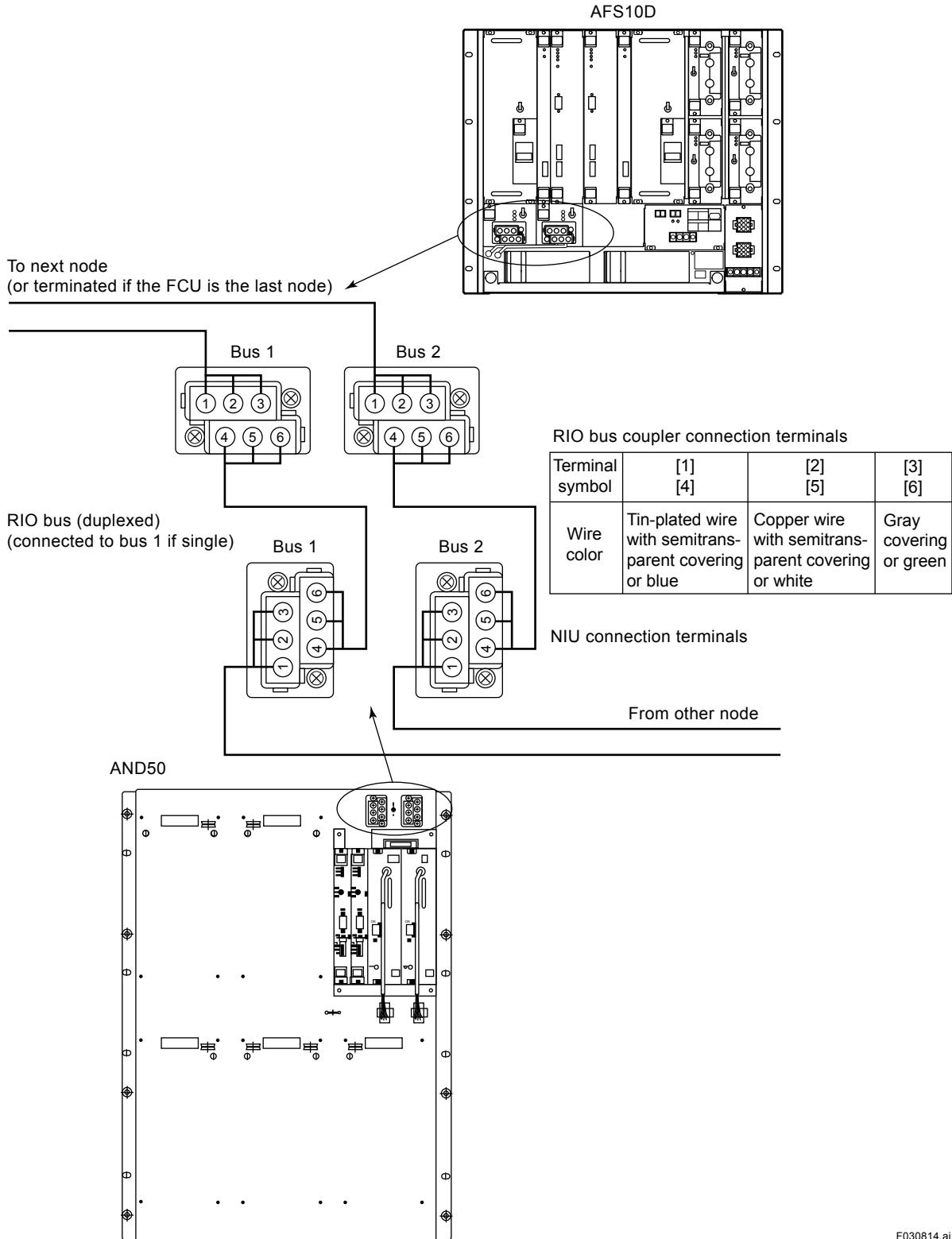
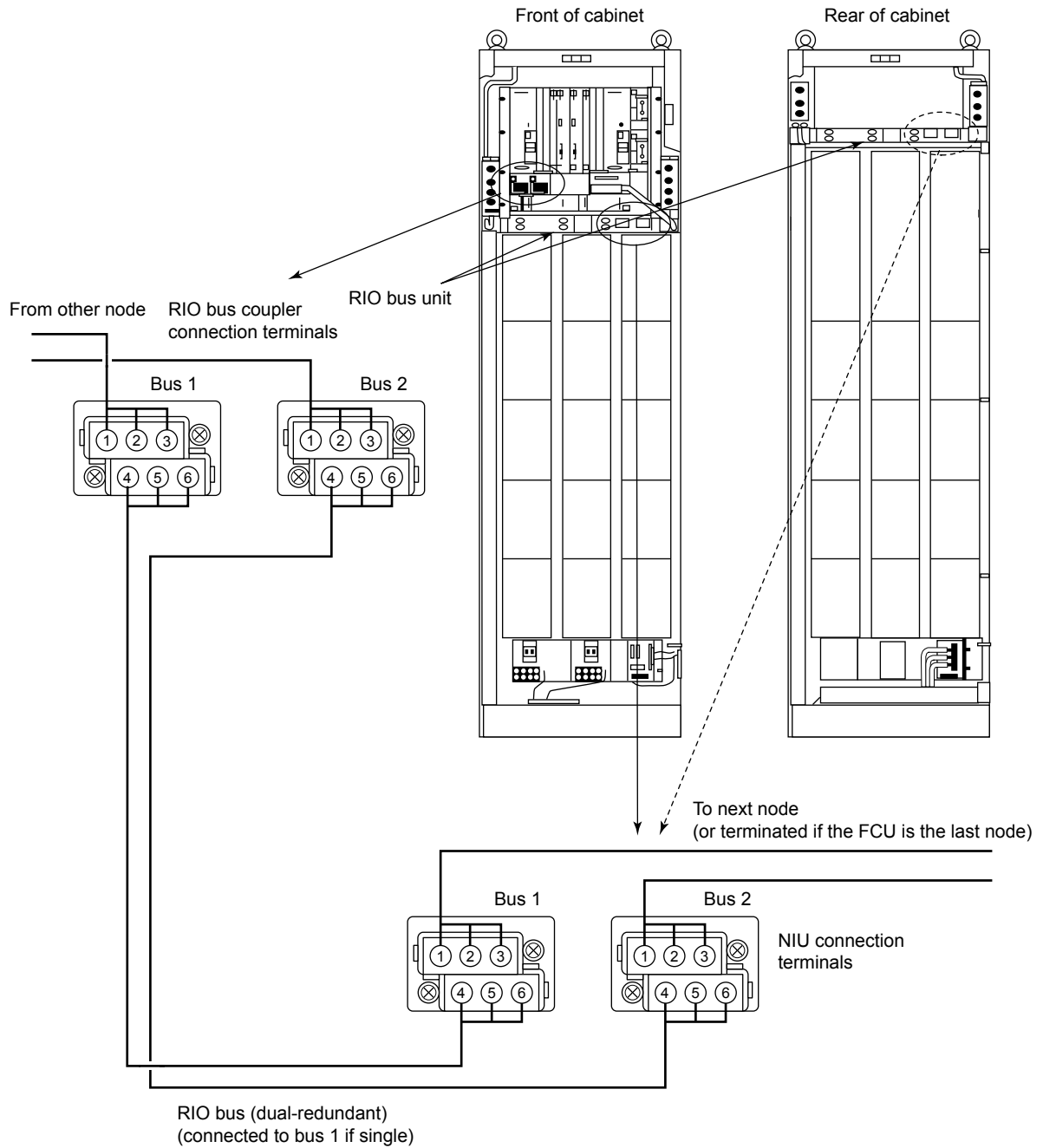

Figure RIO bus Connection (19-inch Rack Mountable Type)

F030814.ai

RIO Bus (with Cabinet)



Note: Connect the FCU to the next node from the rear RIO bus unit, or terminate it if it is the last node.

F030815.ai

Figure RIO bus Connection (with Cabinet)

RIO Bus Arrangement

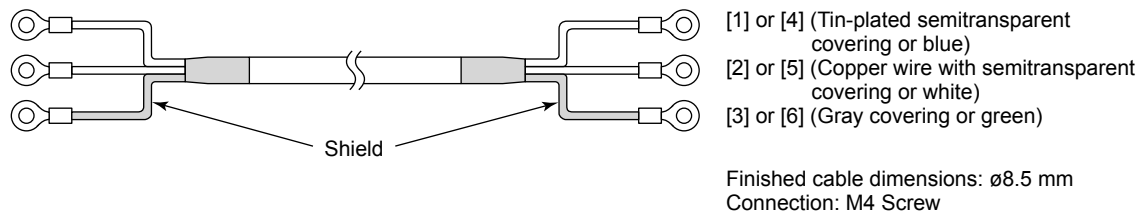

F030816.ai

Figure RIO bus Cable

- **Grounding RIO Bus**
 To avoid shock hazards, ground RIO bus cables at one point every segment. For grounding, see relevant IM.

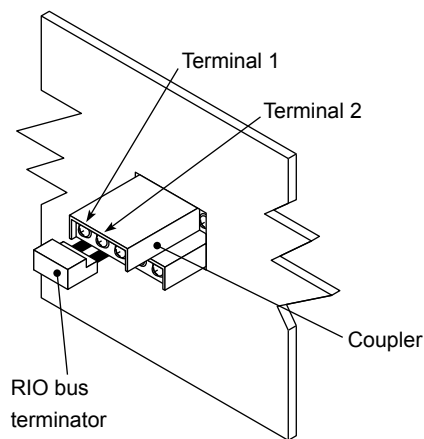

Terminator connection terminals:
 Between [1] and [2]
 Connection: M4 Screw

There is no need to remove terminal screws, but simply loosen them; screws are designed not to fall out. (See figure).

F030817.ai

Figure RIO Bus Terminator and Mounting Condition

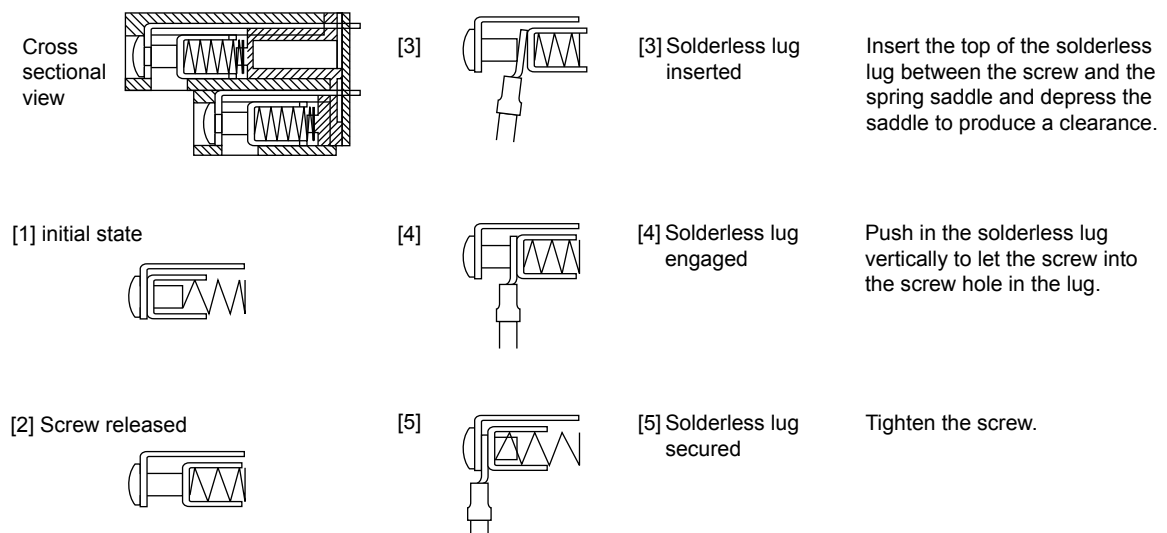

F030818.ai

Figure Connecting and terminating the RIO bus Cable

3.9 Connecting Optical Fiber Cable

The optical bus repeater is used to convert part of the system's communication bus to optical fiber cables. The optical fiber cables must be provided by user.

Connect the optical transceivers of a pair of optical bus repeaters as shown below:

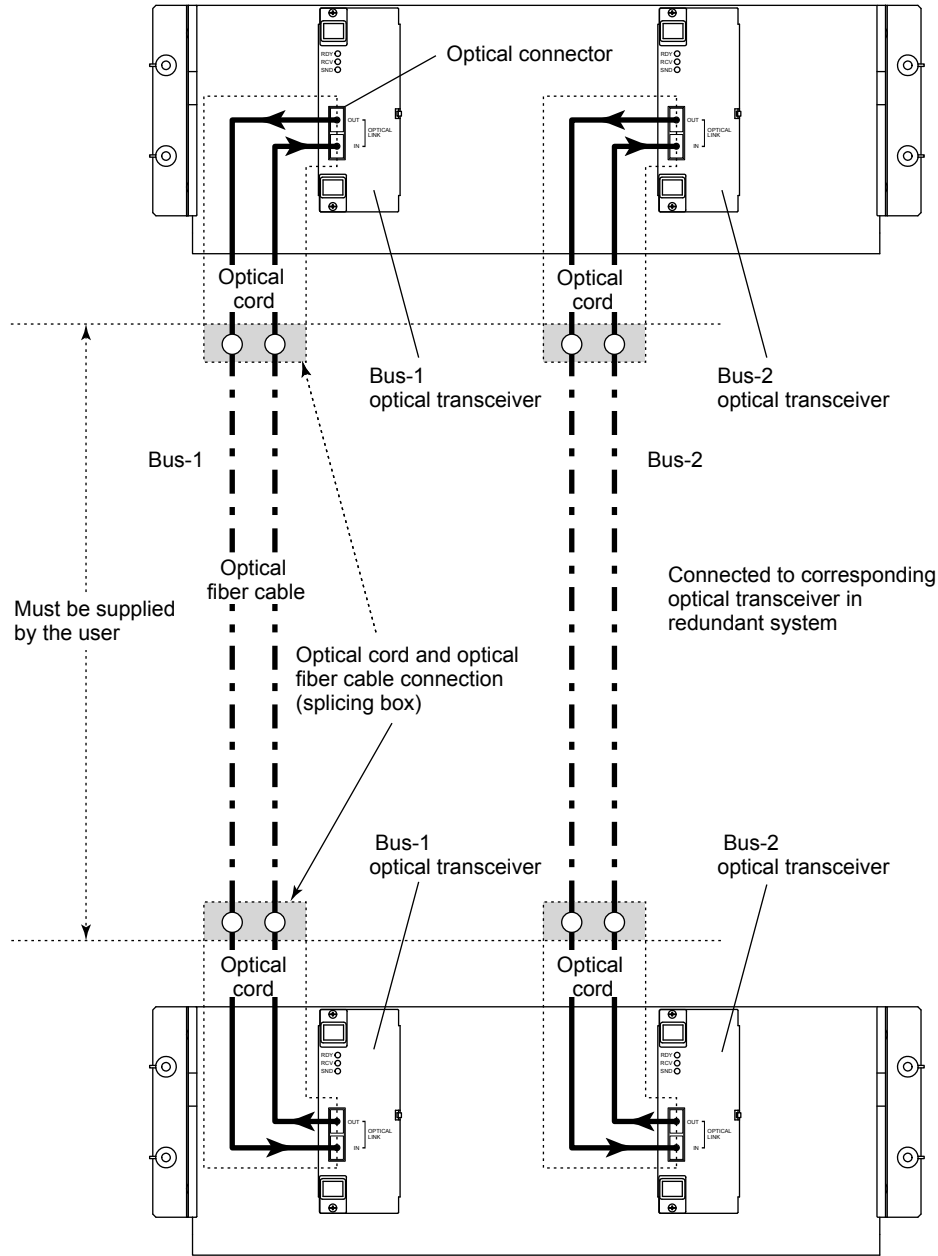

F030901.ai

Figure Example of Optical Cord and Optical Fiber Cable Connection
(In redundant optical bus repeater (YNT5□1D) for Max.4 km)

To Use GI 62.5/125 Optical Fiber Cable

It is recommended to use a GI 50/125 optical fiber cable (core diameter 50 μm , clad diameter 125 μm) for an optical bus repeater.

To use a GI 62.5/125 optical fiber cable, follow the procedure below. Compared to a GI 50/125 optical fiber cable, a large volume of light is emitted by connecting a GI 62.5/125 optical fiber cable to the output connector of an optical bus repeater. If the input connector of an optical bus repeater receives a larger volume of light than the maximum volume of light to be received, data transmission fails. Therefore, connect a GI 62.5/125 optical fiber cable according to the procedure below.

1. To restrict a volume of light, you must insert a 10 m of GI 50/125 optical cord between the output connector of an optical bus repeater and a GI 62.5/125 optical fiber cable in the field.
2. To connect the two types of cables, use an optical adaptor inside the splicing box located under the floor near a cabinet to install an optical bus repeater.

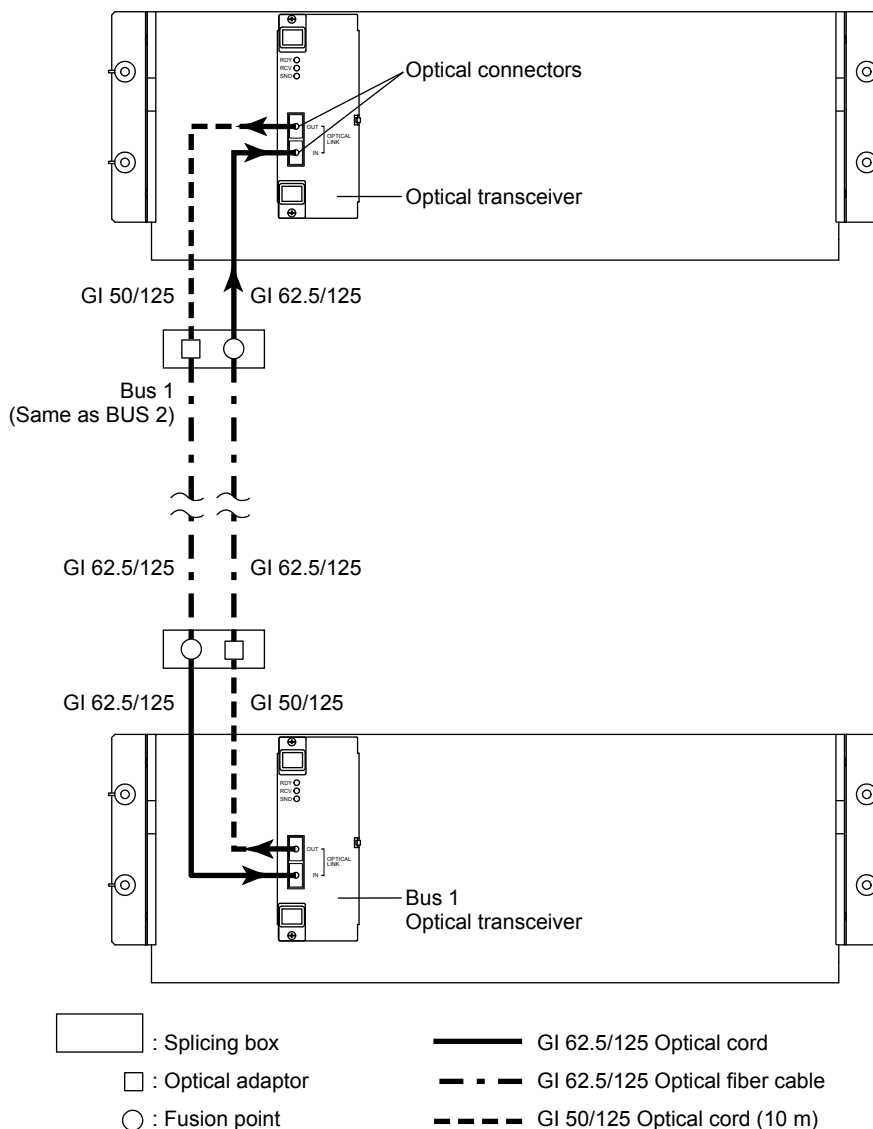

F030902.ai

Figure Connection of GI 62.5/125 Optical Fiber Cable

3.10 Alarm and Contact I/O Cabling



CAUTION

It is recommended to use signal cables, relay terminals, relays, power units, and other devices that comply with CSA 61010-1 or CSA 60950-1 (for 100-120 V AC) or EN 61010-1 (for 220-240 V AC) standards when connected to contact output terminal.

Status Contact Output Connection

Each CS 3000 device is provided with a terminal which makes contact output to external if a power failure or processor failure is detected. The output contact rating of each device is shown below.

Table Status Contact Output

Device	Status Contact Output	Contact Rating
LPCKIT, YPCKIT	Built-in PC failure	250 V AC/30 V DC, 2 A, 125 VA
AFS10S/AFS10D, AFG10S/AFG10D (19-inch Rack Mountable Type)	Power and processor failure	30 V DC, 0.3 A
AFS20S/AFS20D, AFG20S/AFG20D (with Cabinet)	Power and processor failure	250 V AC/30 V DC, 2 A, 125 VA
AFS30S/AFS30D, AFG30S/AFG30D (19-inch Rack Mountable Type)	Power and processor failure	30 V DC, 0.3 A
AFS40S/AFS40D, AFG40S/AFG40D (with Cabinet)	Power and processor failure	250 V AC/30 V DC, 2 A, 125 VA
AFF50S/AFF50D (19-inch Rack Mountable Type)	Power and processor failure	30 V DC, 0.3 A
PFCS/PFCD	Power and processor failure	30 V DC, 0.3 A
ABC11S/ABC11D	Power and processor failure	30 V DC, 0.3 A
MHM/MHC	Power	30 V DC, 0.3 A

Use of Lamps

When you want to turn on lamps using contacts, use the following lamps:

- The rated voltage of lamp does not exceed the rated contact voltage.
- When using incandescent lamps, their rush current does not exceed the rated contact current. It is considered to be 10 to 15 times the rated current. If the rush current exceed the rated contact current, use a dim lamp resistor or a rush current preventing resistor. It is recommended to use a dim lamp resistor using 40 to 50 % of the lamp current rating, or a rush current preventing resistor using 80 to 90 % of the lamp current rating. A dim lamp resistor permits detection of lamp failure.

Be sure to test the lamp before installation.

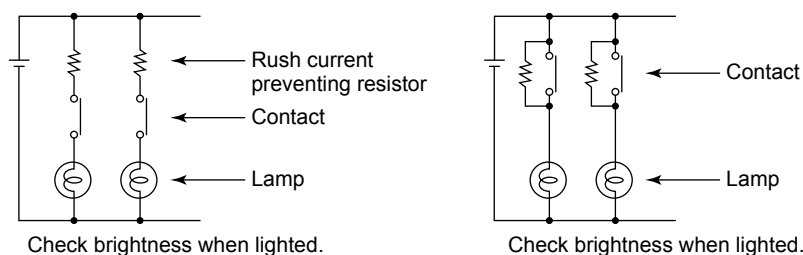

F031001.ai

Figure Examples of Using Lamps

Use of Relays

Contact protection and surge absorption can be provided in various manners. When using contacts output to drive relays and solenoids, the following precautions should be taken:

- Install a diode in parallel to induction load for noise prevention and contact protection.
- Use a relay circuit with voltage rating as low as possible for increased reliability.
- Select a diode having a reverse withstand voltage which is 10 times or larger than a circuit voltage and a forward current which exceeds a load current.



IMPORTANT

Relays and solenoids cause reverse electromotive voltages at both coil ends due to inductive load. This phenomenon causes contact damage or noise, leading to device errors and adversely affecting the entire system.

When a DC Power Supply Is Used

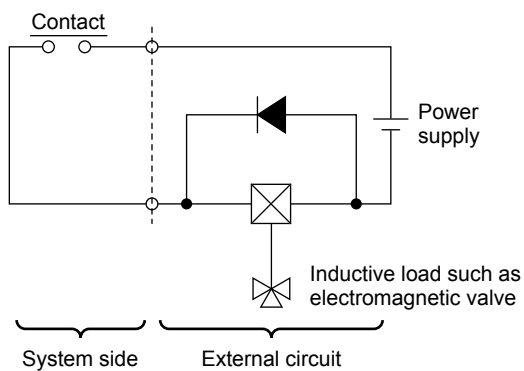
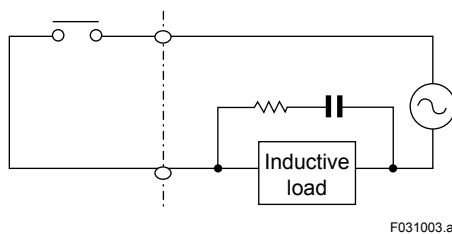

Figure Example of Using Diode for Contact Protection

When a AC (or DC) Power Supply Is Used

- Shunt the load with a resistor (R) and a capacitor (C).
- The recovery time increases when using relays or solenoid valves.



Note: Avoid direct AC voltage input to the contact output terminal on 19-inch rack mountable type.

Figure Example of Capacitor/Resistor-protected Circuit

4. Installation Specifications

This section summarizes power consumption, in-rush current, breaker ratings, parts durability and other data for the installation of CS 3000 system.

Electrical Specifications

Power consumption (current) and other electrical data are shown below:

Table Electrical Specifications (1/3)

Equipment	Input-voltage range		Max. power consumption (VA, A) (*1)	Heating value J/h (*2)
	Voltage (V AC)	Frequency (Hz)		
Reference value LPCKIT Enclosed Display Style Console Type HIS LCD Single Stacked (built in General Purpose PC) (*3)	100-120	50/60±3	520 VA	1370 × 10 ³ (380 W)
	220-240		550 VA	
Reference value LPCKIT Enclosed Display Style Console Type HIS LCD Dual Stacked (built in General Purpose PC) (*3)	100-120	50/60±3	590 VA	1620 × 10 ³ (450 W)
	220-240		630 VA	
Reference value YPCKIT Open Display Style Console Type HIS LCD Single Stacked (built in General Purpose PC) (*3)	100-120	50/60±3	560 VA	1370 × 10 ³ (380 W)
	220-240		590 VA	
Reference value YPCKIT Opened Display Style Console Type HIS LCD Dual Stacked (built in General Purpose PC) (*3)	100-120	50/60±3	670 VA	1550 × 10 ³ (430 W)
	220-240		720 VA	
AFS10S, AFG10S 19-inch Rack Mountable Type (excluding node) Field Control Unit	100-120	50/60±3	250 VA	432 × 10 ³ (120 W)
	220-240		250 VA	
	24 V DC		4.5 A	
AFS10D, AFG10D 19-inch Rack Mountable Type (excluding node) Duplexed Field Control Unit	100-120	50/60±3	400 VA	720 × 10 ³ (200 W)
	220-240		410 VA	
	24 V DC		8 A	
AFS20S, AFG20S With Cabinet (excluding node) Field Control Unit	100-120	50/60±3	300 VA	540 × 10 ³ (150 W)
	220-240		330 VA	
	24 V DC		6 A	
AFS20D, AFG20D With Cabinet (excluding node) Duplexed Field Control Unit	100-120	50/60±3	450 VA	828 × 10 ³ (230 W)
	220-240		480 VA	
	24 V DC		10 A	
AFS20S, AFG20S With Cabinet (including node) Field Control Unit	100-120	50/60±3	1700 VA	3960 × 10 ³ (1100 W)
	220-240		2000 VA	
	24 V DC		50 A	
AFS20D, AFG20D With Cabinet (including node) Duplexed Field Control Unit	100-120	50/60±3	1700 VA	3960 × 10 ³ (1100 W)
	220-240		2000 VA	
	24 V DC		50 A	

*1: Power consumption in steady operation is indicated in VA (AC) or A (DC). When power consumption varies according to the installed number of equipment, power consumption by the maximum number of units installed is listed.

*2: Heating value in steady operation is indicated in Joule/hour. When heating value varies according to the installed number of equipment, heating value by the maximum number of units installed is listed.

*3: The value obtained on the premise that the maximum power consumption of built-in PC is 400 VA. The service outlet is not included.

Table Electrical Specifications (2/3)

Equipment	Input-voltage range		Max. power consumption (VA, A) (*1)	Heating value J/h (*2)
	Voltage (V AC)	Frequency (Hz)		
PFCS field control station (excl. I/O)	100-120	50/60±3	200 VA	680 × 10 ³ (190 W)
	220-240		300 VA	
	24 V DC		9 A	
PFCD field control station (excl. I/O)	100-120	50/60±3	200 VA	680 × 10 ³ (190 W)
	220-240		300 VA	
	24 V DC		9 A	
ANS20/ANS50 Node Interface Unit	100-120	50/60±3	320 VA	540 × 10 ³ (150 W)
	220-240		320 VA	
	24 V DC		7.5 A	
AND20/AND50 Dual-Redundant Node Interface Unit	100-120	50/60±3	320 VA	540 × 10 ³ (150 W)
	220-240		320 VA	
	24 V DC		7.5 A	
ACB21 I/O Expansion Cabinet (at maximum installation of RIO)	100-120	50/60±3	1600 VA	3240 × 10 ³ (900 W)
	220-240		1700 VA	
	24 V DC		42 A	
AFS30S, AFG30S 19-inch Rack Mountable Type Field Control Unit for FIO	100-120	50/60±3	250 VA	432 × 10 ³ (120 W)
	220-240		250 VA	
	24 V DC		4.5 A	
AFS30D, AFG30D 19-inch Rack Mountable Type Duplexed Field Control Unit for FIO	100-120	50/60±3	400 VA	720 × 10 ³ (200 W)
	220-240		410 VA	
	24 V DC		8 A	
AFS40S, AFG40S with Cabinet (excluding node) Field Control Unit for FIO	100-120	50/60±3	300 VA	540 × 10 ³ (150 W)
	220-240		330 VA	
	24 V DC		6 A	
AFS40D, AFG40D with Cabinet (excluding node) Duplexed Field Control Unit for FIO	100-120	50/60±3	450 VA	828 × 10 ³ (230 W)
	220-240		480 VA	
	24 V DC		10 A	
AFS40S, AFG40S with Cabinet (including node) Field Control Unit for FIO	100-120	50/60±3	1800 VA	4680 × 10 ³ (1300 W)
	220-240		2100 VA	
	24 V DC		53 A	
AFS40D, AFG40D with Cabinet (including node) Duplexed Field Control Unit for FIO	100-120	50/60±3	1800 VA	4680 × 10 ³ (1300 W)
	220-240		2100 VA	
	24 V DC		53 A	
AFF50S 19-inch Rack Mountable Type Field Control Unit for FIO	100-120	50/60±3	200 VA	432 × 10 ³ (120 W)
	220-240		230 VA	
	24 V DC		5.5 A	
AFF50D 19-inch Rack Mountable Type Duplexed Field Control Unit for FIO	100-120	50/60±3	200 VA	432 × 10 ³ (120 W)
	220-240		230 VA	
	24 V DC		5.5 A	
ANB10S ESB Bus Node Unit (at maximum installation of FIO)	100-120	50/60±3	200 VA	432 × 10 ³ (120 W)
	220-240		230 VA	
	24 V DC		5.5 A	

*1: Power consumption in steady operation is indicated in VA (AC) or A (DC). When power consumption varies according to the installed number of equipment, power consumption by the maximum number of units installed is listed.

*2: Heating value in steady operation is indicated in Joule/hour. When heating value varies according to the installed number of equipment, heating value by the maximum number of units installed is listed.

Table Electrical Specifications (3/3)

Equipment	Input-voltage range		Max. power consumption (VA, A) (*1)	Heating value J/h (*2)
	Voltage (V AC)	Frequency (Hz)		
ANB10D Duplexed ESB Bus Node Unit (at maximum installation of FIO)	100-120	50/60±3	200 VA	432 x 10 ³ (120 W)
	220-240		230 VA	
	24 V DC	5.5 A		
ANR10S ER Bus Node Unit (at maximum installation of FIO)	100-120	50/60±3	200 VA	432 x 10 ³ (120 W)
	220-240		230 VA	
	24 V DC	5.5 A		
ANR10D Duplexed ER Bus Node Unit (at maximum installation of FIO)	100-120	50/60±3	200 VA	432 x 10 ³ (120 W)
	220-240		230 VA	
	24 V DC	5.5 A		
ACB41 I/O Expansion Cabinet (at maximum installation of FIO)	100-120	50/60±3	1700 VA	4680 x 10 ³ (1300 W)
	220-240		1900 VA	
	24 V DC	46 A		
YNT511/YNT522 single optical bus repeater (*4)	100-120	50/60±3	40 VA	80 x 10 ³ (23 W)
	220-240		55 VA	
	24 V DC	1 A		
YNT512 single bus repeater (*4)	100-120	50/60±3	40 VA	80 x 10 ³ (23 W)
	220-240		55 VA	
	24 V DC	1 A		
ACG10S Communication Gateway Unit	100-120	50/60±3	100 VA	270 x 10 ³ (75 W)
	220-240		100 VA	
ABC11S Bus Converter	100-120	50/60±3	180 VA	288 x 10 ³ (80 W)
	220-240		180 VA	
	24 V DC	4 A		
ABC11D Dual-Redundant Bus Converter	100-120	50/60±3	320 VA	540 x 10 ³ (150 W)
	220-240		320 VA	
	24 V DC	7.5 A		

- *1: Power consumption in steady operation is indicated in VA (AC) or A (DC). When power consumption varies according to the installed number of equipment, power consumption by the maximum number of units installed is listed.
- *2: Heating value in steady operation is indicated in Joule/hour. When heating value varies according to the installed number of equipment, heating value by the maximum number of units installed is listed.
- *3: The value obtained on the premise that the maximum power consumption of built-in PC is 400 VA. The service outlet is not included.
- *4: Power consumption and heating value double in the case of redundant system.

Maximum Power Consumption Depending on Installed Nodes (Model AND20)

No. of installed nodes	Max. power consumption (VA)						
	0	1	2	3	4	5	6
AFS20D	450	770	1060	1260	1440	1580	1700
ACB21 (Expansion Cabinet)	80	400	720	1000	1250	1440	1600

Note: Node load is at max. installation

Actual Power-On In-Rush Current of Each Component

Actual in-rush current data measured for each component is listed below:

Table System Equipment Power-On In-Rush Current

Model		In-Rush current (A)		In-Rush current (A)		In-Rush current (A)	
		100 V AC		220 V AC		24 V DC	
		Primary	Secondary	Primary	Secondary	Primary	Secondary
AFS10S	FCU (19-inch rack mountable type)	32	38	103	45	17	21
AFS10D	Duplexed FCU (19-inch rack mountable type)	56	58	208	67	32	39
AFG10S	FCU (19-inch rack mountable type)	32	38	103	45	17	21
AFG10D	Duplexed FCU (19-inch rack mountable type)	56	58	208	67	32	39
AFS20S	FCU (with cabinet) (with maximum no. of nodes installed)	133	118	418	267	67	59
AFS20D	Duplexed FCU (with cabinet) (with maximum no. of nodes installed)	133	118	418	267	67	59
AFG20S	FCU (with Cabinet) (with maximum no. of nodes installed)	133	118	418	267	67	59
AFG20D	Duplexed FCU (with Cabinet) (with maximum no. of nodes installed)	133	118	418	267	67	59
AFS30S	FCU (for FIO, 19-inch rack mountable type)	32	38	103	45	17	21
AFS30D	Duplexed FCU (for FIO, 19-inch rack mountable type)	56	58	208	67	32	39
AFG30S	FCU (for FIO, 19-inch rack mountable type)	32	38	103	45	17	21
AFG30D	Duplexed FCU (for FIO, 19-inch rack mountable type)	56	58	208	67	32	39
AFS40S	Field Control Unit (for FIO, with cabinet) (with maximum no. of 10 node units installed)	190	80	180	80	67	59
AFS40D	Duplexed Field Control Unit (for FIO, with cabinet) (with maximum no. of 10 node units installed)	220	140	260	120	67	59
AFG40S	FCU (with Cabinet) (with maximum no. of 10 node units installed)	190	80	180	80	67	59
AFG40D	Duplexed FCU (with Cabinet) (with maximum no. of 10 node units installed)	220	140	260	120	67	59
AFF50S	FCU (for FIO, rack mountable type) (with maximum no. of node units installed)	165	25	260	22	63	48
AFF50D	Duplexed FCU (for FIO, rack mountable type) (with maximum no. of node units installed)	165	25	260	22	63	48
PFCS/ PFCD	Field Control Station (incl. 5 I/O units)	24	17	36	19	25	24
AND20/ AND50	Node interface unit (duplexed) (with 5 I/O units loaded)	31	66	173	88	18	12
ACB21	I/O expansion cabinet (with maximum no. of nodes installed)	117	117	440	256	64	63
YNT511D, YNT522D	Optical bus repeater (dual-redundant)	48	5	112	12	40	4
YNT512D	Bus repeater (dual-redundant)	48	5	112	12	40	4
ACG10S	Communication gateway unit	25	4	50	8	–	–
ABC11D	Bus converter (dual-redundant)	56	58	208	67	33	37
ACB41	I/O expansion cabinet (with maximum no. of node units installed)	117	117	440	256	64	63
ANR10D	Node unit for dual-redundant ER bus	62	5	124	5	30	23

Input current peak values and waveforms, influenced by input impedance, varies with system configurations, line sharing with other systems, and other factors. The rush current data shown above were measured under predetermined conditions (see below). Please note that the values are subject to change.

The power input circuit, with an in-rush current limiting circuit, restrains primary in-rush current, turning any current exceeding the limit to secondary and successive rush current.

Measurement Conditions

Input voltage: 132/264 V AC, 50 Hz, and 24 V DC

Power line impedance: Approx. 0.4 ohms (external line and internal impedance)

Turn-on timing: At 50 Hz, 90° or 5 ms after the AC zero-crossing point

(60 Hz data are almost identical to the 50 Hz data shown above.)

Note

- The timing of the maximum primary/secondary in-rush current varies with devices.
- The restart in-rush current after a momentary power failure exceeds the above data and its timing is also different.
- For a system composed of multiple pieces of equipment, the in-rush current is normally smaller than the total of the in-rush currents by individual pieces of equipment.

Maximum Power Consumption of FIO

Table Maximum Power Consumption of FIO (1/2)

Model name	Name	Max. current consumption 5 V DC (mA)	Max. current consumption 24 V DC (mA)
Bus Interface Module			
EB401	ER Bus Interface Master Module	700	–
Analog I/O Modules			
AAI141	Analog Input Module (4 to 20 mA, 16-channel, Non-Isolated)	310	450
AAV141	Analog Input Module (1 to 5 V, 16-channel, Non-Isolated)	350	–
AAV142	Analog Input Module (-10 to +10 V, 16-channel, Non-Isolated)	350	–
AAI841	Analog I/O Module (4 to 20 mA, 8-channel Input/8-channel Output, Non-Isolated)	310	500
AAB841	Analog I/O Module (1 to 5 V Input, 4 to 20 mA Output, 8-channel Input/ 8-channel Output, Non-Isolated)	310	250
AAV542	Analog Output Module (-10 to +10 V, 16-channel, Non-Isolated)	450	–
AAI143	Analog Input Module (4 to 20 mA, 16-channel, Isolated)	230	540
AAI543	Analog Output Module (4 to 20 mA, 16-channel, Isolated)	230	540
AAV144	Analog Input Module (-10 to +10 V, 16-channel, Isolated)	500	–
AAV544	Analog Output Module (-10 to +10 V, 16-channel, Isolated)	860	–
AAT141	TC/mV Input Module (TC: R, J, K, E, T, B, S, N/mV: -100 to 150 mV, 16-channel, Isolated)	450	–
AAR181	RTD Input Module (RTD: Pt100 ohm, 12-channel, Isolated)	450	–
AAI135	Analog Input Module (4 to 20 mA, 8-channel, Isolated Channels)	360	450
AAI835	Analog I/O Module (4 to 20 mA, 4-channel Input/4-channel Output, Isolated Channels)	360	450
AAT145	TC/mV Input Module (TC: R, J, K, E, T, B, S, N/mV: -100 to 150 mV, 16-channel, Isolated Channels)	350	–
AAR145	RTD/POT Input Module (RTD: Pt100 ohm/POT: 0 to 10 kohm, 16-channel, Isolated Channels)	350	–
AAP135	Pulse Input Module (8-channel, Pulse Count, 0 to 10 kHz, Isolated Channels)	300	400
AAP149	Pulse Input Module for Compatible PM1 (16-channel, Pulse Count, 0 to 6 kHz, Non-Isolated)	400	–
AAP849	Pulse Input/Analog Output Module for compatible PAC (Pulse count Input, 4 to 20mA Output, 8-channel Input/8-channel Output, Non-Isolated)	310	250

Table Maximum Power Consumption of FIO (2/2)

Model name	Name	Max. Current consumption 5 V DC (mA)	Max. current consumption 24 V DC (mA)
Digital I/O Modules			
ADV151	Digital Input Module (32-channel, 24 V DC)	500	–
ADV551	Digital Output Module (32-channel, 24 V DC)	700	–
ADV141	Digital Input Module (16-channel, 100 to 120 V AC)	500	–
ADV142	Digital Input Module (16-channel, 220 to 240 V AC)	500	–
ADV157	Digital Input Module (32-channel, 24 V DC, Pressure Clamp Terminal Support Only)	350	–
ADV557	Digital Output Module (32-channel, 24 V DC, Pressure Clamp Terminal Support Only)	550	–
ADV161	Digital Input Module (64-channel, 24 V DC)	550	–
ADV561	Digital Output Module (64-channel, 24 V DC)	780	–
ADR541	Relay Output Module (16-channel, 24 to 110 V DC/100 to 240 V AC)	780	–
ADV859	Digital I/O Module for Compatible ST2 (16-channel Input/16-channel Output, Isolated Channels)	450	–
ADV159	Digital Input Module for Compatible ST3 (32-channel Input, Isolated Channels)	330	–
ADV559	Digital Output Module for Compatible ST4 (32-channel Output, Isolated Channels)	570	–
ADV869	Digital I/O Module for Compatible ST5 (32-channel Input/32-channel Output, Common Minus Side Every 16-channel)	800	–
ADV169	Digital Input Module for Compatible ST6 (64-channel Input, Common Minus Side Every 16-channel)	800	–
ADV569	Digital Output Module for Compatible ST7 (64-channel Output, Common Minus Side Every 16-channel)	800	–
Communication Modules			
ALR111	RS-232C Communication Module (2-Port, 1200 bps to 115.2 kbps)	500	–
ALR121	RS-422/RS-485 Communication Module (2-Port, 1200 bps to 115.2 kbps)	500	–
ALE111	Ethernet Communication Module (1-Port, 10 Mbps)	500	–
ALF111	Foundation Fieldbus (FF-H1) Communication Module (4-Ports, 31.25 kbps)	500	–
ALP111	PROFIBUS-DP Communication Module	700	–
Analog I/O Modules with Built-in Barrier			
ASI133	Analog Input Module (4 to 20 mA, 8-channel, Isolated)	150	450
ASI533	Analog Output Module (4 to 20 mA, 8-channel, Isolated)	150	350
AST143	TC/mV Input Module (TC: B, E, J, K, N, R, S, T / mV: -100 to 150 mV, -50 to 75 mV, 16-channel, Isolated)	150	80
ASR133	RTD/POT Input Module (RTD: Pt50, Pt100, Pt200, Pt500, Pt1000, Ni100, Ni200, Ni120 / POT: 0 to 10 kΩ, 8-channel, Isolated)	150	60
Digital I/O Modules with Built-in Barrier			
ASD143	Digital Input Module (16-channel, NAMUR compatible, Isolated)	150	110
ASD533	Digital Output Module (8-channel, Isolated)	150	500

Maximum Power Consumption of RIO

Table Max. Power Consumption of RIO (1/2)

Module	Name	Max. Power Consumption 5 V DC (A)
Analog I/O modules		
AAM10	Current/voltage input module (simplified)	0.25
AAM11	Current/voltage input module	0.3
AAM11B	Current/voltage input module (for BRAIN type)	0.3
AAM21	mV, thermocouple, resistance temperature detector input module	0.15
AAM21J	mV, thermocouple, resistance temperature detector input module (for IEC 584-1995, IEC 751-1995)	0.15
APM11	Pulse input module	0.4
AAM50	Current output module	0.25
AAM51	Current/voltage output module	0.3
AMC80	Multipoint control analog I/O module	2.0
Relay I/O modules		
ADM15R	Relay input module	2.0
ADM55R	Relay output module	2.0
Multiplexer modules		
AMM12T	Voltage input multiplexer module (16-contact, Terminal type)	0.5
AMM22M	mV input multiplexer module (16-contact, Terminal type)	0.5
AMM22T	Thermocouple input multiplexer module (16-contact, Terminal type)	0.5
AMM22TJ	Thermocouple input multiplexer module (16-contact, Terminal type, For IEC 584-1995)	0.5
AMM32T	Resistance temperature detector input multiplexer module (16-contact, Terminal type)	0.5
AMM32TJ	Resistance temperature detector input multiplexer module (16-contact, Terminal type, for IEC 751-1995)	0.5
AMM42T	2-wire transmitter input multiplexer module (16-contact, Terminal type)	4.0
AMM52T	Current output multiplexer module (16-contact, Terminal type)	4.0
AMM12C	Voltage input multiplexer module (connector-type)	0.5
AMM22C	mV input multiplexer module (connector-type)	0.5
AMM25C	Thermocouple input multiplexer module (15-contact, with RJC input port)	0.5
AMM32C	Thermocouple input multiplexer module (connector-type)	0.5
AMM32CJ	Thermocouple input multiplexer module (connector-type, for IEC 751-1995)	0.5

Table Max. Power Consumption of RIO (2/2)

Module	Name	Max. Power Consumption 5 V DC (A)
Digital I/O modules		
ADM11T	Contact input module (16-contact, Terminal type)	0.6
ADM12T	Contact input module (32-contact, Terminal type)	0.6
ADM51T	Contact output module (16-contact, Terminal type)	0.6
ADM52T	Contact output module (32-contact, Terminal type)	0.6
ADM11C	Contact input module (16-point, Connector type)	0.6
ADM12C	Contact input module (32-point, Connector type)	0.6
ADM51C	Contact output module (16-point, Connector type)	0.6
ADM52C	Contact output module (32-point, Connector type)	0.6
Communication module		
ACM11	RS-232C Communication module	1.0
ACM12	RS-422/RS-485 Communication module	1.0
ACM21	RS-232C Communication card	1.0
ACM22	RS-422/RS-485 Communication card	1.0
ACM71	Ethernet Communication module (for PFC□)	1.2
ACF11	Fieldbus Communication module	1.4
ACP71	PROFIBUS Communication module	0.6

Breaker Specifications

Breaker ratings are listed below:

Table Breaker Ratings (1/2)

Equipment	Built-in breaker rating (A/V)	External breaker rating (Recommend) (A/V) (*1)
LPCKIT, YPCKIT console assembly (100 V AC)	15/250	30/250
LPCKIT, YPCKIT console assembly (220 V AC)	15/250	30/250
PFCS field control station (100 V AC system)	6.3/250 (fuse)	15/250
PFCS field control station (220 V AC system)	6.3/250 (fuse)	15/250
PFCS field control station (24 V DC)	15/250 (fuse)	30/24
PFCD dual-redundant field control station (100 V AC system)	6.3/250 (fuse)	15/250
PFCD dual-redundant field control station (220 V AC system)	6.3/250 (fuse)	15/250
PFCD dual-redundant field control station (24 V DC)	15/250 (fuse)	30/24
YNT511/YNT522 optical bus repeater (100 V AC system)	1/250 (fuse)	5/250
YNT511/YNT522 optical bus repeater (220 V AC system)	2/250 (fuse)	10/250
YNT511/YNT522 optical bus repeater (24 V DC)	2/250 (fuse)	10/250
YNT512 bus repeater (100 V AC system)	1/250 (fuse)	5/250
YNT512 bus repeater (220 V AC system)	2/250 (fuse)	10/250
YNT512 bus repeater (24 V DC)	2/250 (fuse)	10/250
AFS10S/AFS10D, AFG10S/AFG10D field control unit (100 V AC)	8/250 (fuse)	15/250
AFS10S/AFS10D, AFG10S/AFG10D field control unit (220 V AC)	6.3/250 (fuse)	15/250
AFS10S/AFS10D, AFG10S/AFG10D field control unit (24 V DC)	15/250 (fuse)	30/24
ANS50/AND50 Node interface unit (100 V AC)	8/250 (fuse)	15/250
ANS50/AND50 Node interface unit (220 V AC)	6.3/250 (fuse)	15/250
ANS50/AND50 Node interface unit (24 V DC)	15/250 (fuse)	30/24
AFS20S/AFS20D, AFG20S/AFG20D field control unit (100, 220 V AC)	15/250 (two) (*2)	40/250
AFS20S/AFS20D, AFG20S/AFG20D field control unit (24 V DC)	30/24 (two)	100/24
ACB21 I/O expansion cabinet (100, 220 V AC)	15/250 (two) (*2)	40/250
ACB21 I/O expansion cabinet (24 V DC)	30/24 (two)	100/24

Table Breaker Ratings (2/2)

Equipment	Built-in breaker rating (A/V)	External breaker rating (Recommend) (A/V) (*1)
AFS30S/AFS30D, AFG30S/AFG30D field control unit (100 V AC)	8/250 (fuse)	15/250
AFS30S/AFS30D, AFG30S/AFG30D field control unit (220 V AC)	8/250 (fuse)	15/250
AFS30S/AFS30D, AFG30S/AFG30D field control unit (24 V DC)	15/25 (fuse)	30/24
AFS40S/AFS40D, AFG40S/AFG40D field control unit (100, 220 V AC)	20/250 (two) (*3)	50/250
AFS40S/AFS40D, AFG40S/AFG40D field control unit (24 V DC)	30/24 (two)	100/24
AFF50S/AFF50D field control unit (100, 220 V AC)	6.3/250 (fuse)	15/250
AFF50S/AFF50D field control unit (24 V DC)	10/250 (fuse)	20/250
ANB10S/10D ESB bus node unit (100, 220 V AC) ANR10S/10D ER bus node unit (100, 220 V AC)	6.3/250 (fuse)	15/250
ANB10S/10D ESB bus node unit (24 V DC) ANR10S/10D ER bus node unit (24 V DC)	10/250 (fuse)	20/250
ACB41 I/O expansion cabinet (100, 220 V AC)	20/250 (two) (*3)	40/250
ACB41 I/O expansion cabinet (24 V DC)	30/24 (two)	100/24
ABC11S/ABC11D Bus converter (100 V AC)	8/250 (fuse)	15/250
ABC11S/ABC11D Bus converter (220 V AC)	6.3/250 (fuse)	15/250
ABC11S/ABC11D Bus converter (24 V DC)	15/250 (fuse)	30/24
ACG10S Communication gateway unit (100 V AC)	3/250 (fuse)	5/250
ACG10S Communication gateway unit (220 V AC)	3.15/250 (fuse)	5/250

- *1: Recommended.
- *2: Breaker consists of two 15AT NFBs (no-fuse breakers), as shown in the following figure. Up to 30 A can be fed. However, when 15 A or more passes through one breaker, both NFBs shut down.
- *3: Breaker consists of two 20AT NFBs (no-fuse breakers), as shown in the following figure. Up to 40 A can be fed. However, when 20 A or more passes through one breaker, both NFBs shut down.

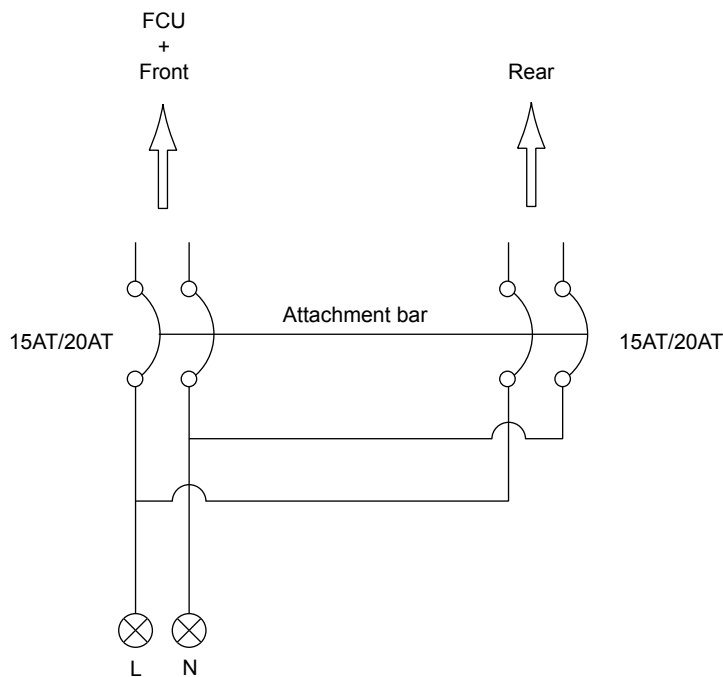

F040107.ai

Figure Breaker

Parts Durability

Some parts require periodical replacements. For preventative maintenance, the recommended intervals to replace parts with a life span of less than 10 years are shown in the table below.

Users can replace parts indicated by “Yes” in the “user replacement”. For other parts, contact Yokogawa for replacement.

There can be some parts having defined life spans in resale material mounted to a console kit. If that is the case, replace the parts according to a manual of resale material.

The average ambient temperature shown in the table is the average temperature surrounding the corresponding parts.

When the parts are installed in a cabinet of Yokogawa product, though varies with actual installations, in general, the temperature inside of the cabinet is about 10 °C higher than the temperature outside the cabinet.

Note: Random failures within the recommended replacement intervals may occur in some parts.



IMPORTANT

The reliability and life span of an electronic equipment greatly depend on the operating environment. It is essential for ensuring reliable operation and prolonged life span that the equipment is used not only within the range of environment resistance standards but also in a more satisfactory environment. For instance, if a piece of equipment is always used at 35 °C when its operating temperature ranges from 5 to 40 °C, generally its estimated failure rate almost doubles compared with operation at 25 °C.

If corrosive gas is present in the environment, the corrosion of the equipment’s contacts and printed circuit boards is accelerated more than in a cleaner environment, resulting in a reduced life span. Moreover, if dust can be easily generated in the environment, filters must be cleaned and replaced more often.

LPCKIT

Table Periodic Replacement Parts Having Defined Life Spans (When average LPCKIT ambient temperature is 30 °C)

Part names	Part numbers	Recommended replacement cycle	Replacement by user	Remarks
Air filter	T9070CB	1 year	Yes	Wash every 3 months.
Power supply unit	S9961UK	8 years	No	The electrolytic capacitor is a part with a defined life span.
LCD unit	S9211FA	3 years	No	–
Fan unit	AIP601	4 years	Yes	–
Operation keyboard	S9281FA	–	No	Depends on frequency of use.
Fuse	S9518VK	3 years	Yes	For 100 V AC (for service outlet)
	A1353EF	3 years	Yes	For 220 V AC (for service outlet)
Relay	S9725VM	100000 operations	Yes	–

YPCKIT

Table Periodic Replacement Parts Having Defined Life Spans (When average YPCKIT ambient temperature is 30 °C)

Part names	Part numbers	Recommended replacement cycle	Replacement by user	Remarks
LCD unit	S9205FA	3 years	Yes	100 V AC
	S9206FA	3 years	Yes	200 V AC
Operation keyboard	S9282FA	–	No	Depends on frequency of use.
AC adapter (For operation keyboard)	A1519UP	5 years	No	–
Fuse	S9518VK	3 years	Yes	For 100 V AC (for service outlet)
	A1353EF	3 years	Yes	For 220 V AC (for service outlet)
Relay	S9725VM	100000 operations	Yes	–

LOPSVMK

Table Periodic Replacement Parts Having Defined Life Spans (When average LOPSMK ambient temperature is 30 °C)

Part names	Part numbers	Recommended replacement cycle	Replacement by user	Remarks
Air filter	T9003BY	1 year	Yes	Wash every 3 months.
Power supply unit	S9961UK	8 years	No	The electrolytic capacitor is a part with a defined life span.
LCD unit	S9225FA	4 years	No	–
Fan unit(*1)	A1025EM	4 years	Yes	100 V AC
	S9000VK	4 years	Yes	110/115 V AC
	A1043EM	4 years	Yes	120 V AC
Operation keyboard	S9284FA or S9363FA	–	No	Depends on frequency of use.
Fuse	S9518VK	3 years	Yes	for fan
Relay	S9725VM	100000 operations	Yes	–

*1: Users can replace a fan unit by themselves, but they are also required to do soldering. YOKOGAWA service department can take on the work.

LOPXLMK**Table** Periodic Replacement Parts Having Defined Life Spans (When average LOPXLMK ambient temperature is 30 °C)

Part names	Part numbers	Recommended replacement cycle	Replacement by user	Remarks
Air filter	T9050NY	1 year	Yes	Wash every 3 months.
Power supply unit	S9961UK	8 years	No	The electrolytic capacitor is a part with a defined life span.
LCD unit	S9388FA	3 years	No	–
LCD unit	S9389FA	3 years	No	–
Fan unit	AIP601	4 years	Yes	–
Operation keyboard	S9390FA	–	No	Depends on frequency of use.
Fuse	S9518VK	3 years	Yes	For 100 V AC (for service outlet)
	A1353EF	3 years	Yes	For 220 V AC (for service outlet)
Relay	S9725VM	100000 operations	Yes	–

AIP826/AIP827**Table** Periodic Replacement Parts Having Defined Life Spans (When average AIP826/AIP827 ambient temperature is 30 °C)

Part names	Part numbers	Recommended replacement cycle	Replacement by user	Remarks
AC adapter	A1519UP	5 years	Yes	–
AIP826/AIP827	–	–	No	Depends on frequency of use.

**AFS10□, AFG10□/AFS20□, AFG20□/ACB21, ACB41/ ANS50/AND50, ANS20/
AND20**

Table Periodic Replacement Parts Having Defined Life Spans

Part names	Part numbers	Recommended replacement cycle	Used in:				Replacement by user	Remarks
			A F □ 1 0	A F □ 2 0	A C B □ 1	A N □ □ 0		
Aluminium Electrolytic Capacitor (in power supply unit)	(PW301)	8 years	X	X			No	100 V AC Average ambient temperature 40 °C or less
	(PW302)	8 years	X	X			No	220 V AC Average ambient temperature 40 °C or less
	(PW304)	8 years	X	X			No	24 V DC Average ambient temperature 40 °C or less
	(PW401)	8 years				X	No	100 V AC Average ambient temperature 40 °C or less
	(PW402)	8 years				X	No	220 V AC Average ambient temperature 40 °C or less
	(PW404)	8 years				X	No	24 V DC Average ambient temperature 40 °C or less
Fan Unit	AIP601	4 years	X	X	X		Yes	
Air Filter	T9070CK	1 year	X				Yes	For nest fan. Wash every 3 months.
	T9070CB	1 year		X	X		Yes	For door fan. Wash every 3 months.
Battery Pack	S9400UK S9765UK	3 years	X	X			Yes	Average ambient temperature 30 °C or less
		1.5 years	X	X			Yes	Average ambient temperature 40 °C or less
		9 months	X	X			Yes	Average ambient temperature 50 °C or less
Fuse	S9580VK	3 years	X	X			No	PW302
	S9502VK	3 years	X	X			No	PW301
	S9504VK	3 years	X	X		X	No	PW304, PW404
	S9506VK	3 years				X	No	PW401
	S9579VK	3 years				X	No	PW402

X: Usage

AFS30□, AFG30□/AFS40□, AFG40□/ANB10□/ANR10□

Table Periodic Replacement Parts Having Defined Life Spans

Part names	Part numbers	Recommended replacement cycle	Used in:				Replacement by user	Remarks
			A F □ 3 0	A F □ 4 0	A N B 1 0	A N R 1 0		
Aluminium Electrolytic Capacitor (in power supply unit)	(PW301)	8 years	X	X			No	100 V AC Average ambient temperature 40 °C or less
	(PW302)	8 years	X	X			No	220 V AC Average ambient temperature 40 °C or less
	(PW304)	8 years	X	X			No	24 V DC Average ambient temperature 40 °C or less
	(PW481)	8 years			X	X	No	100 V AC Average ambient temperature 40 °C or less
	(PW482)	8 years			X	X	No	220 V AC Average ambient temperature 40 °C or less
	(PW484)	8 years			X	X	No	24 V DC Average ambient temperature 40 °C or less
Fan Unit	AIP601	4 years	X	X			Yes	
Air Filter	T9070CK	1 year	X				Yes	For nest fan. Wash every 3 months.
	T9070CB	1 year		X			Yes	For door fan. Wash every 3 months.
Battery Pack	S9400UK S9765UK	3 years	X	X			Yes	Average ambient temperature 30 °C or less
		1.5 years	X	X			Yes	Average ambient temperature 40 °C or less
		9 months	X	X			Yes	Average ambient temperature 50 °C or less
Fuse	S9580VK	3 years	X	X			No	PW302
	S9502VK	3 years	X	X			No	PW301
	S9504VK	3 years	X	X			No	PW304, PW404
	S9109VK	8 years			X	X	No	PW481, PW482
	A1546EF	8 years			X	X	No	PW484

X: Usage

AFF50□**Table Periodic Replacement Parts Having Defined Life Spans**

Part names	Part numbers	Recommended replacement cycle	Replacement by user	Remarks
Power supply module	PW481	8 years	Yes	100 - 120 V AC Average ambient temperature 40 °C or less
	PW482	8 years	Yes	220 - 240 V AC Average ambient temperature 40 °C or less
	PW484	8 years	Yes	24 V DC Average ambient temperature 40 °C or less
Battery Pack	S9129FA	3 years	Yes	Average ambient temperature 30 °C or less
		1.5 years	Yes	Average ambient temperature 40 °C or less
		9 months	Yes	Average ambient temperature 50 °C or less
Aluminium Electrolytic Capacitor (in power supply unit)	(PW481)	8 years	No	100 V AC Average ambient temperature 40 °C or less
	(PW482)	8 years	No	220 V AC Average ambient temperature 40 °C or less
	(PW484)	8 years	No	24 V DC Average ambient temperature 40 °C or less
Built-in power fuse	S9109VK	8 years	No	PW481
	S9109VK	8 years	No	PW482
	A1546EF	8 years	No	PW484

PFCS/PFCD Field Control Station**Table Periodic Replacement Parts Having Defined Life Spans**

Part names	Part numbers	Recommended replacement cycle	Replacement by user	Remarks
Power unit (100-120 V AC)	PW701	8 years	Yes	Average ambient temperature 40 °C or less
Power unit (220-240 V AC)	PW702	8 years	Yes	Average ambient temperature 40 °C or less
Power unit (24 V DC)	PW704	8 years	Yes	Average ambient temperature 40 °C or less
Battery Pack	S9765UK	3 years	Yes	Average ambient temperature 30 °C or less
		1.5 years	Yes	Average ambient temperature 40 °C or less
		9 months	Yes	Average ambient temperature 50 °C or less
Aluminium Electrolytic Capacitor (in power supply unit)	(PW701)	8 years	No	100 V AC Average ambient temperature 40 °C or less
	(PW702)	8 years	No	220 V AC Average ambient temperature 40 °C or less
	(PW704)	8 years	No	24 V DC Average ambient temperature 40 °C or less
Fuse	S9578VK	3 years	No	For PW701, 6.3A
	S9578VK	3 years	No	For PW702, 6.3A
	S9504VK	3 years	No	For PW704, 15A

YNT511/YNT522 Optical Bus Repeater and YNT512 Bus Repeater

Table Periodic Replacement Parts Having Defined Life Spans

Part names	Part numbers	Recommended replacement cycle	Replacement by user	Remarks
Power unit (100-120 V AC)	PW501	8 years	Yes	Average ambient temperature 40 °C or less
Power unit (220-240 V AC)	PW502	8 years	Yes	Average ambient temperature 40 °C or less
Power unit (24 V DC)	PW504	8 years	Yes	Average ambient temperature 40 °C or less
Fuse	A1361EF	3 years	Yes	For PW501, 1 A
	A1349EF	3 years	Yes	For PW502, 2 A
	A1363EF	3 years	Yes	For PW504, 2 A

ACG10S

Table Periodic Replacement Parts Having Defined Life Spans

Part names	Part numbers	Recommended replacement cycle	Replacement by user	Remarks
Power unit	A1057UP	8 years	No	100/220 V AC power supply Average ambient temperature 40 °C or less
Fan unit	S9402UK	4 years	Yes	
Battery Pack	S9400UK	3 years	Yes	Average ambient temperature 30 °C or less
		1.5 years	Yes	Average ambient temperature 40 °C or less
		9 months	Yes	Average ambient temperature 50 °C or less
Air filter	T9051MK	1 year	Yes	Clean it every three months
Lithium battery	–	10 years	No	For real time clock
Fuse	S9517VK	3 years	Yes	100 V AC power supply (3A)
	A1351EF	3 years	Yes	220 V AC power supply (3.15 A)

ABC11S, ABC11D**Table Periodic Replacement Parts Having Defined Life Spans**

Part names	Part numbers	Recommended Replacement Interval	Replacement by user	Remarks
Air Filter	T9070CK	1 year	Yes	Clean it every three months
Fun	AIP601	4 years	Yes	
Battery Pack	S9400UK	3 years	Yes	Average ambient temperature 30 °C or less
		1.5 years	Yes	Average ambient temperature 40 °C or less
		9 months	Yes	Average ambient temperature 50 °C or less
Aluminium Electrolytic Capacitor (in power supply unit)	(PW301)	8 years	No	100 V AC Average ambient temperature 40 °C or less
	(PW302)	8 years	No	220 V AC Average ambient temperature 40 °C or less
	(PW304)	8 years	No	24 V DC Average ambient temperature 40 °C or less
Built-in power fuse	S9052VK	3 years	No	100-120 V AC, 250 V, 8 A, F
	S9580VK	3 years	No	220-240 V AC, 250 V, 6.3 A, F
	S9504VK	3 years	No	24 V DC, 250 V, 15 A, F

Paint Colors**Table Paint Colors**

Painted section	Paint color (Reference Munsell values in parentheses)	Major unit types
Basic color	Frosty white (2.5Y8.4/1.2)	LPCKIT, YPCKIT, YAX801, AFS20S/AFS20D, AFS40S/AFS40D, AFG20S/AFG20D, AFG40S/AFG40D
Channel base	Spring Black (3.3PB2.5/0.5)	LPH21C, YPCKIT, YAX801, AFS20S/AFS20D, AFS40S/AFS40D, AFG20S/AFG20D, AFG40S/AFG40D

Notes for Installing Devices

This section describes notes for installing devices and installation restrictions.

Rules of Connection for the Housekeeping Unit (HKU)

The HKU owns a function which controls temperature rises by rotating the fans at high speed if the intake temperature becomes 35 °C or more, or the exhaust temperature becomes 40 °C or more in the I/O expansion cabinet (ACB21).

When installing cabinet installation type nodes (when suffix codes -S1 or -S2 are selected) into the I/O expansion cabinet (ACB21), a connection between the HKU and the node is needed.

When connecting, even with generation, a specification of which node is to be connected to the HKU must be made. When installing cabinet installation type nodes into the I/O expansion cabinet (ACB21), the connection between the HKU and node will be prioritized by R3→R2→R1→F3→F2→F1 from the node installation position.

In other words, connections in the HKU will be made as follows. If R3 is being installed, connection will be to the R3. If R2 without R3 is being installed, connection will be made to the R2. If R1 is being installed without R3 and R2, connection will be made to the R1. If F3 is being installed without R3, R2, R1, then connection will be made to F3.

For example, if nodes are installed in F1, R1, R2, then the HKU will be connected to the node in R2.

If no nodes are installed in the cabinet, as the HKU will not have anything to connect to, the HKU will not function and the fan will rotate at high speed.

The diagram below shows the connection position of the HKU cable to the node.

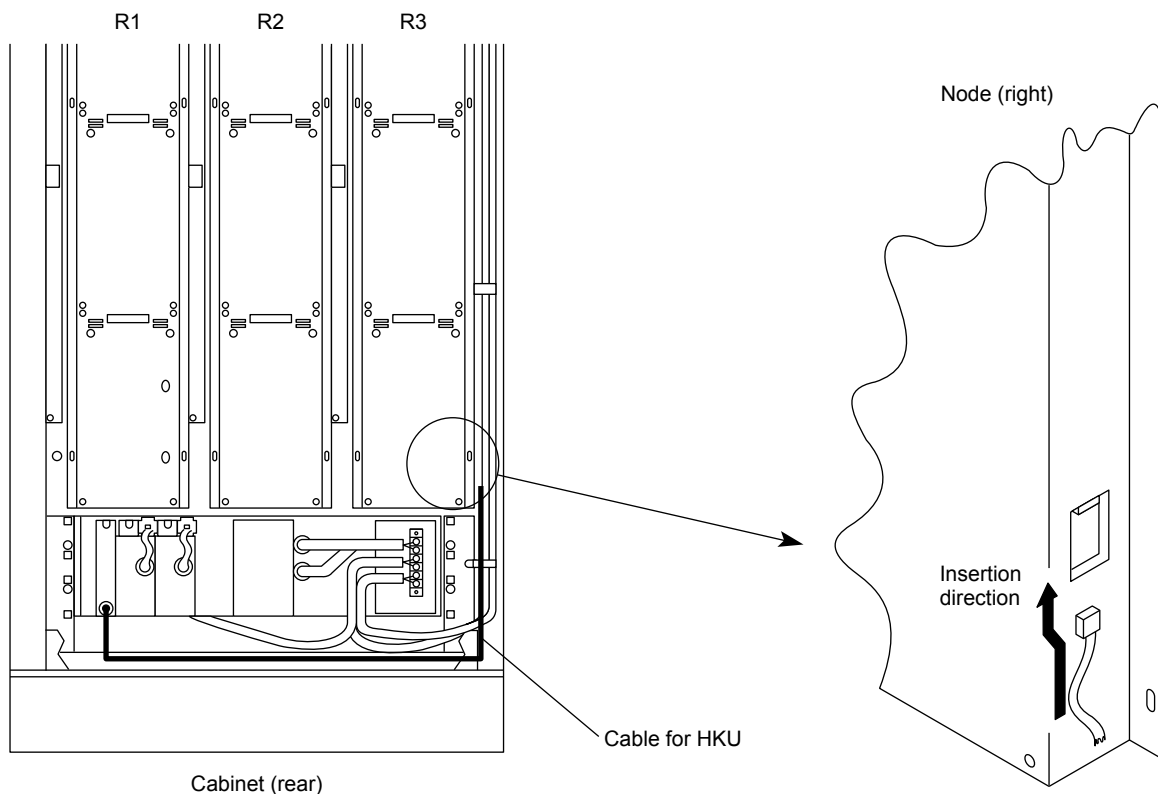

F040105.ai

Figure Housekeeping Unit Connection (Connected to Node in R3)

5. Post-installation Inspection and Environmental Preservation

Post-installation Inspection

Upon the completion of installation of instrumentation, before turning on the power inspect the following items in the list below to avoid system contamination by dust and moisture dust and condensation.

Table Inspection before Power On

	Inspection items (daily inspection/maintenance items)
Environment	<input type="checkbox"/> No water intrusion from cable ducts. <input type="checkbox"/> No wind/rain blow-in <input type="checkbox"/> Air-conditioned <input type="checkbox"/> Cable ducts and cabinet bottoms covered to prevent entry of wind, dust, moisture <input type="checkbox"/> Cabinets and surroundings cleaned <input type="checkbox"/> No dust entering from air vents <input type="checkbox"/> Free of salty, ferrous, corrosive gas <input type="checkbox"/> No direct sunlight on equipment
Equipment	<input type="checkbox"/> No condensation or traces on cabinet interior/exterior <input type="checkbox"/> No discoloration or rust on cabinet interior/exterior <input type="checkbox"/> No condensation or traces on cards (disconnect cards on the upper, middle, and lower stands, and left and right sides of the cabinet to check that there is no condensation on the cards or defects anywhere in the cabinet.) <input type="checkbox"/> No dust remaining inside cabinet

It is recommended that you turn on the power in the presence of Yokogawa when turning it on first.

Post-installation Environment Preservation

The following precautions should be taken to preserve the proper operating environment after the system has been installed:

- Seal the pits if they are shared by equipment in other rooms, preventing entry of dust and moisture from the other rooms.
- Seal all cable ducts of equipment and building with putty upon completion of cabling.
- Always turn on air conditioner. Turning it on/off may cause condensation inside equipment. If you turn on the power of an air conditioner after a long stop, turn on the air conditioner first and the system. Otherwise condensation may occur.
- Monitor and record ambient temperature and humidity. To maintain the reliability of the equipment be sure to remove the cause if they fluctuate violently.
- Note that leaving exits and entrances open during installation, or leaving open cable ducts while pulling cables, may result in condensation.

CENTUM CS 3000

Installation Guidance

TI 33Q01J10-01E 13th Edition

INDEX

Symbols

16-Point Digital I/O Modules ADM11T, ADM51T	3-76
19-inch Rack-mount Devices and Wiring	3-24
19-inch Rack Mount Devices	2-23
24 V DC Power Distribution Board	3-8
32-Point Digital I/O Modules ADM12T, ADM52T	3-76

A

ABC11S, ABC11D	4-19
ABC11S/ABC11D Bus Converter	3-27
ACG10S	4-18
ACG10S Communication Gateway Unit	3-26
Actual Power-On In-Rush Current of Each Component	4-4
AC Power Distribution Board	3-8
AC Power Specification	1-14
AFF50S/AFF50D, ANR10S/ANR10D Wiring	3-37
AFF50S/AFF50D Field Control Unit (19-inch Rack Mountable Type)	3-17
AFF50□	4-17
AFS10S/AFS10D, AFG10S/AFG10D Field Control Unit (19-inch Rack Mountable Type)	3-14
AFS10□, AFG10□/AFS20□, AFG20□/ACB21, ACB41/ ANS50/AND50, ANS20/AND20	4-15
AFS20S/AFS20D, AFG20S/AFG20D Field Control Unit (with Cabinet), AFS40S/AFS40D, AFG40S/AFG40D Field Control Unit (with Cabinet) ACB21 I/O Expansion Cabinet, ACB41 I/O Expansion Cabinet	3-16
AFS30S/AFS30D, AFG30S/AFG30D Field Control Unit (19-inch Rack Mountable Type)	3-15
AFS30□, AFG30□/AFS40□, AFG40□/ANB10□/ ANR10□	4-16
AIP826/AIP827	4-14
Air Conditioner	1-4
Air Purity	1-6
Alarm and Contact I/O Cabling	3-107
Alarm and Control Circuit Cables	3-2

Ambient Temperature	1-32
Analog I/O Modules AAM10, AAM11, AAM11B, AAM21, AAM21J, APM11, AAM50, AAM51	3-67
Analog Input Modules AAM21, AAM21J for Resistance Temperature Detector Signal Input	3-67
ANB10S/ANB10D ESB Bus Node Unit (19-inch Rack Mountable Type)	3-21
ANR10S/ANR10D ER Bus Node Unit (19-inch Rack Mountable Type)	3-22
ANS50/AND50 Node Interface Unit (19-inch Rack Mountable Type)	3-19
Applied Standards	1-8
Areas for Signal Cables from Field	3-34
Attaching Brackets	2-23
Avoid Physical Shock	2-3

B

Breaker Specifications	4-10
------------------------------	------

C

Cabinet	1-20
Cables and Terminals	3-2
Cable Terminals	3-3
Cable Termination	3-7
Cabling	1-18, 3-1
Cabling Requirements	1-31
Card Installation Procedure	2-31
Carrying	2-4
Carrying Space	2-4
Carrying when Headroom is Low	2-5
Clamp Filter Location	3-79
Clamp Filter Parts	3-79
Clearance From The Wall and The Floor Surface	1-3
Combination of Fieldnetwork I/O (FIO) and Terminal Blocks	3-49
Common Method to Determine Power Unit Capacity	1-17

Concrete Floor	2-11	Connecting V net cables (10BASE-5) and V net cables (10BASE-2) Interconnection Example.....	3-90
Condensation.....	1-5	Connection of Fieldbus Communication Module ALF111.....	3-60
Conduit Power-cabling.....	3-10	Connector Type IOU Cabling.....	3-45
Connecting Bus Cable.....	3-88	Connector Type Multiplexer Module and Terminal Board/Terminal Block	3-75
Connecting Ground Cable.....	3-11	Control Bus Adapter.....	3-91
Connecting Optical Fiber Cable.....	3-105	Control Room Design	1-2
Connecting Power	3-5	Control Room Environment	1-5
Connecting Relay Board with Digital I/O Module	3-58	Corrosive-gas Environment Compatibility	1-33
Connecting Signal Cable	3-30	Countermeasures against Static Electricity.....	1-30
Connecting Signal Cables to Terminals (for FIO).....	3-33	Crest factor.....	1-16
Connecting Signal Cables to Terminals (for RIO).....	3-39		
Connecting Signal Cables with Analog I/O Module	3-54	D	
Connecting Signal Cables with Analog I/O Modules	3-66	Desktop Equipment	2-29
Connecting Signal Cables with Communication Modules	3-78	Desk (YAX101, YAX801)	2-30
Connecting Signal Cables with Digital I/O Modules (Connector Type).....	3-77	Digital I/O Modules ADM11C, ADM12C, ADM51C, ADM52C	3-77
Connecting Signal Cables with Digital I/O Modules (Terminal Type).....	3-76	Distance between Cables	1-31
Connecting Signal Cables with Fieldnetwork I/O (FIO)	3-49	Don't Stack Outdoors.....	2-2
Connecting Signal Cables with FIO	3-53	Dual-redundant Pressure Clamp Terminal	3-53
Connecting Signal Cables with MCM Terminal Board	3-72		
Connecting Signal Cables with Multiplexer Modules (Connector Type).....	3-75	E	
Connecting Signal Cables with Multiplexer Modules (Terminal Type).....	3-74	Electric field strength (Electric wave condition)	1-7
Connecting Signal Cables with Multipoint Control Analog I/O Module AMC80.....	3-71	Electrical Specifications	4-1
Connecting Signal Cables with PROFIBUS Communication Module ACP71	3-87	EMC Conformity Standards.....	1-9
Connecting Signal Cables with Pulse Input Module AAP135.....	3-55	Enclosed Display Style Console Assembly (LPCKIT).....	3-12
Connecting Signal Cables with Pulse Input Module APM11	3-68	Enclosed Display Style Console Type HIS (LPCKIT).....	1-20
Connecting Signal Cables with Relay I/O Modules	3-73	ER Bus	3-99
Connecting Signal Cables with Remote I/O (RIO).....	3-64	ESB Bus.....	3-97
Connecting Terminal Board with FIO.....	3-57	Ethernet Communication Module ACM71 (For PFC□).....	3-84
Connecting the Fieldbus Cable and Handling the Shield Mesh for Fieldbus Communication Module ACF11	3-85	Examples of Arrester.....	1-29
Connecting to Pressure-clamp Terminal.....	3-33	Examples of Spark-killer Installation.....	1-29
Connecting V net cables (10BASE-2)	3-89	Example of Implementation of Fieldbus Communication Module ALF111	3-59
Connecting V net cables (10BASE-5)	3-92		
		F	
		Fieldbus Wiring for ALF111 with Pressure Clamp Terminal Block.....	3-61
		Fieldbus Wiring for ALF111 with Terminal Board	3-62
		Field Cable Areas.....	3-40
		FIO Node Unit Wiring in FCU with Cabinet.....	3-35
		FIO Node Unit Wiring in I/O Expansion Cabinet	3-36
		FIO Signal Cabling	3-38

FIO with KS Cable Interface Adapter Cabling	3-38
Flooding- & Dust-proof Floor	1-2
Floor Strength and Space	1-2
Floor Structure	1-2
“Free-access” Floor.....	2-12

G

G3 Environment-compatible Products.....	1-33
General	1-2
Grounding	1-19, 1-20
Grounding Cables	3-3
Grounding Circuit	1-22
Grounding Grouped Cabinets.....	1-23
Grounding Side-by-side Cabinets.....	1-25
Grounding with Lightning Arresters	1-28
Grounding with Other System.....	1-24

H

How to wiring ER bus	3-100
----------------------------	-------

I

I/O Module Nests	3-64
Illumination	1-3
Implementation and Cable Connection of Fieldbus Communication Module ALF111	3-59
In-Rush Current	1-17
Installation	2-10, 2-15, 2-17, 2-20
Installation Direction.....	2-27
Installation Environment Specifications.....	1-10
Installation of Terminator to Terminal Board AEF9D	3-63
Installation on Floor.....	2-11
Installation Procedure	2-26
Installation Specification	1-7
Installation Specifications	4-1
Installing Cabinets in a Side-by-Side Arrangement.....	2-20
Installing Control Bus Interface Card.....	2-31
Installing the Console Type HIS Side-by-Side	2-15
Interconnecting cabinets	2-21
Intersecting Cables	1-32
Isolation Bush.....	2-27
Isolation from Rack	2-26

K

Keep Upright	2-3
KS Cable Interface Adapter	3-54

L

List of Signal Cables for Connection with FIO	3-51
Loading	2-2
Location for Unloading.....	2-3
Location of Storage	2-8
Location Where the UPS Is Installed	2-19
LOPSVMK.....	4-13
LOPXMLK.....	4-14
LPCKIT.....	2-15, 4-12
LPCKIT and YPCKIT with Crane	2-3

M

Magnetic Field	1-6
Maximum Power Consumption Depending on Installed Nodes (Model AND20).....	4-3
Maximum Power Consumption of FIO	4-6
Maximum Power Consumption of RIO	4-8
Measurement Categories	1-8
Measurement Conditions.....	4-5
Measures against EMI	1-32
Modifying the Cabinet Bottom Plates for Cable Wiring.....	3-47
Mounting Clamp Filter (Ferrite Core).....	3-79
Mounting Clamp Filter (Ferrite Core) (for European Market)	3-79
Multiplexer Modules (Connector Type) AMM12C, AMM22C, AMM25C, AMM32C, AMM32CJ.....	3-75
Multipoint Control Analog I/O Module AMC80	3-71

N

Noise Countermeasures	1-26
Noise Sources and Noise Countermeasures	1-27
Note.....	4-5
Notes for Installing Devices	4-20
Notes on Installation	2-23

O

Open Display Style Console Assembly (YPCKIT)	3-13
Open Display Style Console Type HIS (YPCKIT)	1-21
Others	2-2
Outlets for Maintenance.....	1-4
Outline of G3 Environment Compatibility.....	1-35

P

Paint Colors.....	4-19
Parts Durability.....	4-12
Passage.....	2-4
PFCS/PFCD Field Control Station.....	3-18, 4-17
Post-installation Environment Preservation.....	5-1
Post-installation Inspection.....	5-1
Post-installation Inspection and Environmental Preservation.....	5-1
Power and Ground Cabling.....	3-12
Power Cables.....	3-2
Power Cable Termination.....	3-7
Power Distribution Boards.....	3-8
Power Supply System.....	1-14
Power Wiring When Connecting Dual Power Supply Lines.....	3-20
Precautions for Transportation.....	2-2
Pressure Clamp Terminal.....	3-30, 3-53
Pressure Clamp Terminal (for ARS□□M).....	3-32
Pressure Clamp Terminal (for Pressure Clamp Terminal Block).....	3-32
Process I/O Signal Connection.....	3-30
Providing Area for Servicing.....	2-28
Providing Ground Bus in Cabinet/Console Type HIS.....	1-23
Providing Space for Heat Radiation.....	2-27

R

Redundant AAM50/AAM51.....	3-70
Relay Input Module ADM15R.....	3-73
Relay Output Module ADM55R.....	3-73
RIO Bus.....	3-102
RIO Bus (19-inch Rack Mountable Type).....	3-102
RIO Bus (with Cabinet).....	3-103
RIO Bus Arrangement.....	3-104
RIO bus Cabling.....	3-45
RIO Node Wiring in FCU Cabinet.....	3-41
RIO Node Wiring in I/O Expansion Cabinet.....	3-42
Routing Signal Cables.....	3-34, 3-41
RS-232C Communication Card ACM21.....	3-82
RS-232C Communication Module ACM11.....	3-78
RS-422/RS-485 Communication Card ACM22.....	3-83
RS-422/RS-485 Communication Module ACM12.....	3-81
RTD Input Modules AMM32T, AMM32J.....	3-74
Rules of Connection for the Housekeeping Unit (HKU).....	4-20

S

Safety Standards.....	1-8
Selecting a Power System.....	1-16
Separate Grounding.....	1-22
Separator.....	1-31
Servicing Area.....	2-9
Side-by-Side Cabinet Installation.....	1-4
Signal Cables.....	3-2
Signal Cables for Connection with RIO.....	3-65
Signal Cable Termination.....	3-31
Size of Cabling Holes in Floor.....	2-14
Sleeve for pressure clamp terminal.....	3-4
Solderless (crimp-on) Lug Specifications.....	3-7
Solderless Lug.....	3-3, 3-30, 3-31
Source Output Capacity.....	1-16
Standards for Hazardous Location Equipment.....	1-9
Status Contact Output Connection.....	3-107
Steel Floor.....	2-11
Storage.....	2-8
Storage Condition.....	2-8
Storage Environment.....	2-8
Storage of Packed Equipment.....	2-8
Storage of Unpacked Equipment.....	2-8
Structure of Clamp Filter and Mounting.....	3-80
Suppressing Harmonic Current.....	1-17
System Installation Requirements.....	1-1

T

Telephone.....	1-4
Temperatures and Humidity.....	1-5
Terminal Connection.....	3-9
Three-pin Plug Connection.....	3-9
Tools and Parts Required for Joining Cabinets.....	2-22
Tools and Parts Required for Joining Console Type HIS side by side.....	2-19
To Use GI 62.5/125 Optical Fiber Cable.....	3-106
Transportation.....	2-2
Transportation, Storage and Installation.....	2-1
Transportation for LPCKIT, YPCKIT.....	2-2
Type and Maximum Length of Power Cables.....	3-5

U

Unloading	2-3
Unpacking	2-6
Unpacking Procedure	2-7
Use of Lamps	3-107
Use of Relays	3-108
Using Rollers	2-5

V

Vibration	1-6
Voltage Input, mV Input, Thermocouple Input, 2-wire Transmitter Input, Current Output Modules AMM12T, AMM22M, AMM22T, AMM22TJ, AMM42T, AMM52T.	3-74
V net	3-88
V net cable (10BASE-2)	3-95
V net cable (10BASE-5)	3-94
V net Coupler Installation (ACG10S)	3-93

W

When a AC (or DC) Power Supply Is Used	3-108
When a DC Power Supply Is Used	3-108
When Ground Bus Inlet is Provided in Control Room	1-23
When Receiving Current Pulse By Using the Internal Power to Drive the Transmitter (2-wire power supply type)	3-56, 3-69
When Receiving No-Voltage Contact Signals (1)	3-55, 3-68
When Receiving No-Voltage Contact Signals (2)	3-55, 3-68
When Receiving Voltage Pulse By Using the Internal Power to Drive the Transmitter (3-wire power supply type)	3-56, 3-69
When Receiving Voltage Pulse Signals	3-56, 3-69
Windows	1-4
Wiring Console Type HIS	3-46
Wiring of ANS50/AND50 19-inch Rack Mountable Type Node	3-43
Wiring of Console Type HIS (LPCKIT)	3-46
Wiring of Console Type HIS (YPCKIT)	3-46
Wiring of PFCS/PFCD	3-44

Y

YAX101 General-Purpose Desk	3-28
YAX801 General-Purpose Desk	3-29
YNT511/YNT522 Optical Bus Repeater and YNT512 Bus Repeater	4-18
YNT511S/YNT511D, YNT522S/YNT522D Optical Bus Repeater	3-25
YNT512S/YNT512D Bus Repeater	3-25
YPCKIT	2-17, 4-13

Blank Page

Revision Information

- Title : CENTUM CS 3000 Installation Guidance
- Manual No. : TI 33Q01J10-01E

May 1998/1st Edition

Newly published

Nov.1998/2nd Edition

1. System Environment
 - 1.2 Installation Environment Spec.
Vibration conditions (Acceleration formula changed)
Installation environment (Magnetic field, vibration during Transportation, JEIDA-29 environment classes added)
 - 1.3 Power System Design
CS 3000 device power-on in-rush current (LIH21C added)
 - 1.4 Grounding Specifications (LIH21C added)
(Cabinet -> FCU; HIS added)
 - 1.7 Non-incendive (NI) parameters
 - 1.7.2 NI-approved devices, parameters (AMC80 added)
2. Transportation, Storage
 - 2.1 Transportation Cautions
Unloading: Using crane to unload HIS (added)
Carrying into Building
Entrance and Passageway Dimensions: (HIS added)
 - 2.2 Unpacking procedure: (HIS added)
 - 2.4 Installation
 - 2.4.2 HIS Control Panel Configuration (Sectn. added)
3. Wiring
 - 3.2 LIH21C, HIS details added
 - 3.4 LIH21C added
(ANS50/AND50 figure changed)
(AFS20S/20D label added to figure)
(ACF11 Fieldbus added)
 - 3.7 Adapter (changes, additions)
 - 3.9 LIH21C added
4. Installation
 - Table updated, LIH21C added
I/O Module Power Consumption (ACF11, AMM12C added)
Consumables (LIH21C data added)
5. Servicing Area (added)
6. External Demensions (added)

Oct.1999/3rd Edition

1. System Installation Requirements
 - 1.1 Control Room Design
Added "Precaution for Side-by-side Cabinet Installation with Same Series of Products" to "Side-by-Side Cabinet Installation"
 - 1.2 Control Room Environment
Revised "Air Purity"
Revised C-Tick Mark and Standards for Hazardous Location Equipment in "Applied Standards"
Revised table of Equipment Installation Specifications
 - 1.3 Power Supply System
Revised description of rush current of CS 3000 components
 - 1.5 Noise Countermeasures
Added "Grounding with Lighting Arresters"
 - 1.7 Non-Incendive Approval and Parameters
Completely revised
2. Transportation, Storage and Installation
 - 2.1 Precautions for Transportation
Revised "Don't Stack Outdoors" in "Transportation"
Revised title of "Lifting HIS with Crane" to "Lifting Console Type HIS with Crane"

3. Cabling

3.1 Cables & Terminals

Revised descriptions of "Power Cables" and "Grounding Cables"

Revised figure showing Solderless Terminal with Insulating Sheath in "Cable Terminals"

3.2 Connecting Power

Revised table of Solderless Lug Dimensions in "Power Cable Termination"

3.4 Power and Ground Cabling

LIH21C changed to LPH21C

Added "Power Wiring When Connecting Dual Power Supply Lines"

Added "Wiring of Console Type HIS"

3.5 Connecting Signal Cable

Revised "Signal Cable Termination" according to a supplement, and figure showing Solderless Lug

Added "Wiring of Console Type HIS" in "Routing Signal Cables"

3.6 Connecting Signal Cables with I/O Module Nest

Added AAM11B and AAM21J to Analog I/O Modules

Added "Connecting Signal Cables with MCM Terminal Board" in "Signal Connection to AMC80 Multipoint Analog Control I/O Modules"

Added AMM22TJ and AMM32TJ to Multiplexer Module (Terminal Type)

Added AMM22C, AMM25C, AMM32C and AMM32CJ to Multiplexer Module (Connector Type)

Added Multiplexer Module (Connector Type) and Terminal Board

Added AMN33 in figure in "RS-232C Communication Module ACM11" in "Communication Modules"

Added AMN33 in figure in RS-422/RS-485 Communication Module ACM12

Added AMN51 in figure in RS-232C Communication Card ACM21

Added AMN51 in figure in RS-422/RS-485 Communication Card ACM22

Added Ethernet Communication Module ACM71 (for PFC□)

Added AMN33 in figure and revised title of figure in Fieldbus Communication Module ACF11

Added PROFIBUS Communication Module ACP71

3.7 Connecting Bus Cable

Revised figure in "Control-bus Cable Conversion Adapter"

Revised title of V net Coupler Installation (ACG10S)

3.8 Connecting Optical Fiber Cable

Added "To Use GI62.5/125 Optical Fiber Cable"

4. Installation Specifications

Revised LIH21C to LPH21C; and LPH21C 21-inch CRT power consumption and heating value

Added note to "Breaker Specifications"

Added I/O modules to table of Max. Power Consumption of I/O Module

Revised table of LPH21C Human Interface Station in "Parts Durability"

Added "Restrictions on Loading of Input/Output Modules"

6. External Dimensions

Added LPH21C, AAM21J, AMM22TJ, AMM32TJ, AMM22C, AMM25C, AMM32C, AMM32CJ,

ACM71, KS8, TETC, MCM, MTC, TERT, MRT

Feb.2001/4th Edition

Introduction

Added description of FIO

Safety Precautions

Added cautions

1. System Installation Requirements

1.2 Installation Environment Spec.

Revised CE Mark in "Applied Standards"

Revised table of Equipment Installation Specifications

Added table of Installation Environment Standard Used When a General-Purpose PC Is Built in Console Kit

Added table of Classification of JEIDA-63 Environment Specifications

1.3 Power Supply System

Revised title of "Output Capacity Selection" to "Selecting a Power System"

Revised table of System Equipment Power-On In-Rush Current

1.4 Grounding

Revised descriptions of "Grounding"

Revised descriptions of "Grounding Circuit"

1.8 Corrosive-gas Environment Compatibility (added)

-
- 2. Transportation, Storage and Installation
 - 2.1 Precautions for Transportation
 - Revised title of "Lifting Console Type HIS with Crane" to "Lifting Enclosed Display Style Console Type Kit (LPCKIT) with Crane"
 - 2.4.1 Installation on Floor
 - Added description of YPCKIT
 - 2.4.2 Console Type HIS (LPCKIT) Side-by-Side
 - Revised table of Tools and Parts Required for Joining a Pair of HIS
 - 2.4.4 19-inch Rack Mount Devices
 - Added AFS30S/AFS30D and ANR10S/ANR10D
 - 2.4.6 Desk (YAX101, YAX801)
 - Revised title of "Desk (YAX101, YAX701)" to "Desk (YAX101, YAX801)"
 - 3. Cabling
 - 3.1 Cables & Terminals
 - Revised descriptions of "Signal Cables"
 - Added "Sleeve for pressure clamp terminal"
 - 3.4 Power and Ground Cabling
 - Added "Enclosed Display Style Console Assembly (LPCKIT)"
 - Added "Open Display Style Console Assembly (YPCKIT)"
 - Added "AFS30S/AFS30D Field Control Unit"
 - Added "ANR10S/ANR10D ER Bus Node Unit (rack-mounted type)"
 - Added "YAX801 General-Purpose Desk"
 - 3.5 Connecting Signal Cable
 - Added description of Pressure clamp terminal in "Process I/O Signal Connection"
 - Added description of Pressure clamp terminal in "Signal Cable Termination"
 - Added "Connecting Signal Cables to Terminals (for FIO)"
 - Added "Wiring Console Type HIS"
 - 3.6 Connecting Signal Cables with I/O Module
 - 3.6.1 FIO (added)
 - 3.7 Connecting Bus Cable
 - Added "ESB Bus"
 - Added "ER Bus"
 - 3.9 Alarm & Contact I/O Cabling
 - Revised table of Status Contact Output
 - Revised "Use of Lamps"
 - 4. Installation Specifications
 - Revised "Electrical Specifications" (added LPCKIT, YPCKIT, AFS30S, AFS30D, AFS40S, AFS40D, ANB10S, ANB10D, ANR10S, ANR10D and ACB41)
 - Revised table of Paint Colors
 - Revised "Breaker Specifications"
 - Added "Maximum Power Consumption of FIO"
 - Revised "Parts Durability"
 - Revised "Notes for Installing Devices"
 - 6. External Dimensions (deleted)
 - Refer to TI 33Q01J10-02E

Nov.2001/5th Edition

Introduction

- Revised "Power Distribution Board"

1. System Installation Requirements

- 1.1 Control Room Design
 - Added YPCKIT in "Clearance From The Wall"
- 1.3 Power Supply System
 - Revised table of Actual Power-On In-Rush Current of Each Component
- 1.4 Grounding (Added description)
 - Revised Figure in "Open Display Style Console Type HIS (YPCKIT)"
- 1.5 Noise Countermeasures
 - 1.5.1 Noise Sources and Noise Countermeasures (Revised Table)
 - Revised "Grounding with Lightning Arresters"
- 1.6 Cabling Requirements
 - Added description in "Ambient Temperature"
- 1.7 Non-Incendive Approval and Parameters
 - Added FIO

-
- 1.8 Corrosive-gas Environment Compatibility
 - Revised Table
 - 2. Transportation, Storage and Installation
 - 2.1 Precautions for Transportation
 - Added "Transportation for LPCKIT,YPCKIT" in "Transportation"
 - Title changed "Lifting Console Type Kit (LPCKIT,YPCKIT) with Crane"
 - 2.4.1 Installation on Floor (Added description)
 - 2.4.2 Console Type HIS Side-by-Side (changed title)
 - Added "YPCKIT"
 - Revised figure in "Tools and Parts Required for Joining Console Type HIS side by side"
 - 2.4.3 Installing Cabinets in a Side-by-Side arrangement
 - Revised "Installation"
 - 2.4.5 Desktop Equipment
 - Revised description
 - 3. Cabling
 - 3.4 Power and Ground Cabling
 - Revised figure in "Open Display Style Console Assembly (YPCKIT)"
 - Added "ANB10S/ANB10D ESB Bus Node Unit (rack-mounted type)"
 - Revised figure in "ANR10S/ANR10D ER Bus Node Unit (rack-mounted type)"
 - Revised figure in "YAX801 General-Purpose Desk"
 - 3.5 Connecting Signal Cable
 - Revised "Process I/O Signal Connection"
 - Revised IMPORTANT in "Signal Cable Termination"
 - Changed order of the pages describing description for FIO and RIO
 - Revised figure in "Field Area"
 - Revised figure "FIO Node Wiring in FCU with Cabinet"
 - Revised "FIO Node Wiring in I/O Expansion Cabinet"
 - Revised "Modifying the Cabinet Bottom Plates for Cable Wiring"
 - 3.6 Connecting Signal Cables with I/O Module
 - 3.6.1 FIO
 - Revised "Pressure Clamp Terminal"
 - Added "Dual-redundant Pressure Clamp Terminal"
 - Revised table "Connecting FIO Module with Signal Cable"
 - Revise figure and added SEE ALSO in "Example of Implementation of Foundation Fieldbus Communication Module ALF111"
 - Revised figure in "Fieldbus power supply wiring for ALF111 with a pressure clamp terminal"
 - Revised "Fieldbus power supply wiring for connection with a terminal board"
 - 3.6.2 RIO
 - Revised "Fieldbus Communications Module ACF11"
 - 3.7 Connecting Bus Cable
 - Revised "ESB Bus"
 - Added "ER Bus"
 - Added "How to wiring ER bus"
 - 4. Installation Specifications
 - Revised table in "Electrical Specifications"
 - Revised table in "Paint Colors"
 - Revised table and figure in "Breaker Specifications"
 - Revised table in "Maximum Power Consumption of FIO"
 - Revised table in "Operation and Monitoring Device (LPCKIT)"
 - Added "Operation and Monitoring Device (YPCKIT)"
 - Revised "Control Devices (AFS30□,AFG30□/AFS40□, AFG40□/ANB10□/ANR10□)"
 - Added "Limitation on installation of ALR111/ALR121/ALE111"
-

Dec. 2002/6th Edition

Main revision items of this revision

Described about LCD unit used in the enclosed display style console type HIS

Updated the description of the applied standards

Added 16-channel isolated I/O modules

Added I/O modules with the built-in barrier

Described more information about the signal cable connection with I/O modules and their installation restrictions

- 1.2 Vibration: Revised the expression of “total amplitude” to “displacement amplitude”. Therefore, the half values of total amplitudes in the 5th edition are written as the values of displacement amplitudes

Applied Standards: Updated the descriptions, and added the standards on the Type n and intrinsic safety

Installation Environment Specifications:

Corrected normal operation temperature range “0 to 60 °C” to “0 to 50 °C”

Deleted the table “Compliance Factor (Reference Value)” for the HIS console

- 1.7 Updated the descriptions and the non-incendive parameters

Added 16-channel isolated I/O modules and the terminal board for resistance temperature detectors (single and dual-redundant) as NI products

- 1.7.3 Described two cases to compare the non-incendive parameters.

Case 1: Division 2 specific wiring work

Case 2: General-purpose wiring work

Example: Revised the description

- 1.8 G3 Environment-compatible Products: Added 16-channel isolated I/O modules, communication modules and I/O modules with built-in barrier

- 2.1 Transportation: Revised the description

Transportation for LPCKIT, YPCKIT: Revised the description

- 2.4.2 Added the description of a space for a UPS

- 2.4.4 Revised the contents and order of the descriptions

- 2.4.5 Revised the description

- 3.5 Signal Cable Termination: Added screw sizes of the solderless lug

Added “Pressure Clamp Terminal (for ARS□□M)”

- 3.6 Sectioned from 3.6.1 to 3.6.4 and from 3.7.1 to 3.7.9

Added 16-channel isolated I/O modules

Added I/O modules with the built-in barrier

Described more information about the signal cable connection with I/O modules

4. Installation Specifications

Described about LCD unit used in the enclosed display style console type HIS

Described more information about the installation restrictions of the I/O modules

Nov.2003/7th Edition

Main revision items of this revision

Added AFF50S/AFF50D

Added AAV144, AAV544, and ALP111

Deleted description of 15-inch LCD of open display console (YPCKIT)

Introduction

Moved IMPORTANT notes for V net cables to Section 3.8, “Connecting Bus Cable”

- 1.2 Added Measurement Categories

Revised Intrinsic Safety requirements in Applied Standards

Changed Reference TI manual for corrosive gases for Table Equipment Installation Specifications

- 1.3 Moved “Actual Power-On In-Rush Current of Each Component” to Chapter 4

- 1.5.1 Revised Examples of Spark-killer Installation

- 1.7 Corrected errors in writing NI products <FIO>

Added Terminal Block to NI products <RIO>

- 1.7.2 Corrected EB401 data for NI Products and Parameters

- 1.7.3 Corrected conditional expressions for “How to Compare Parameters”

- 1.8 Added modules to Table G3 Environment-compatible Products

- 2.4 Moved description of Servicing Area from Chapter 5

- 2.5.2 Moved description of location where UPS is installed in this item

Corrected YPCKIT joining procedures

- 2.5.4 Moved description of Insulation Bush from Chapter 4

- 2.4.8 Moved Post-installation Inspection to Chapter 5

- 2.4.9 Moved Post-installation Environment Preservation to Chapter 5

-
- 3.2 Added AFF50S/AFF50D Field Control Units to Terminal Connection
 - 3.3 Added AFF50S/AFF50D figures
 - Added FG to ANB10S/ANB10D figures
 - Added FG to ANR10S/ANR10D figures
 - Added figures with ANR10S/ANR10D installed in general-purpose cabinet
 - 3.5 Corrected coating stripped length data for Pressure Clamp Terminal with a sleeve
 - Deleted FG from ANR10S/ANR10D figures
 - 3.6.2 Added AAV144, AAV544, and ALP111 module signal cable connections to Table Signal Cables for Connection with FIO
 - 3.6.3 Added notes to Table Signal Names and I/O Signals of Analog I/O Module
 - Added resistor to Figure No-Voltage contact Input (1) and changed resistor values in Figure 2-Wire Power Supply Type for “Connecting Signal Cables with Pulse Input Module AAP135”
 - 3.6.4 Added notes for AKB336 cable length to Connection of Fieldbus Communication Module ALF111
 - 3.7.1 Added I/O module Nests
 - 3.7.2 Added “List of Signal Cables for Connection with RIO”
 - 3.7.3 Added resistor to Figure No-Voltage Input (1) for Connecting Signal Cables with Pulse Input Module APM11
 - 3.8 Added description of AFF50S/AFF50D to Control Bus Adapter
 - Added description of V net (10BASE-2) cable, T-type connector, and BNC connector cover
 - Added Figure ESB Bus Connection (AFF50D)
 - Added descriptions of Terminator, Clamp Filter, and T-type connector to How to Wiring ER bus
 - 3.10 Added AFF50S/AFF50D and ABC11S/ABC11D devices to Table Status Contact Output
4. Installation Specifications
- Deleted Note: For the electrical specifications of the enclosed display style console using CRT
 - Added AFF50S/AFF50D specifications to Table Electrical Specifications
 - Added data for AFF50S and AFF50D to Table System Equipment Power-On In-Rush Current
 - Corrected data for ANR10D in Table System Equipment Power-On In-Rush Current
 - Corrected 24 V DC data for ANS50/AND50 Node interface unit in Table Breaker Ratings
 - Added AFF50S and AFF50D Field Control Units to Table Breaker Ratings
 - Corrected ADV161 data in Table Maximum Power Consumption of FIO
 - Added data for AAV144, AAV544, and ALP111 to Table Maximum Power Consumption of FIO
 - Corrected data for YPCKIT in Parts durability
 - Added data for Control Devices (AFF50□) and Bus Converters (ABC11S and ABC11D) to Parts durability
 - Deleted Installation restriction for the high-speed nest for analog I/O modules (Model AMN12)
 - Deleted Installation restrictions when using thermocouple input multiplexer modules
 - Deleted Installation restrictions when using thermocouple input (Using 19-inch Rack Mount)
 - Deleted Restrictions on Loading of Input/Output Modules for RIO
 - Deleted FIO Node Unit Installation Restriction
 - Deleted Limitation on installation of ALR111/ALR121/ALE111
 - Deleted Limitation on installation of Foundation Fieldbus ALF111
 - Deleted FIO I/O Module Duplexing & Installation
 - Deleted Protection of FIO Module Vacant Slots
 - Deleted Limitations of Installation under the Ambient Operating Temperature Conditions
 - Deleted Ambient Temperature and Operation restrictions of Remote Nodes
 - Deleted Note for EB401 single configuration
 - Deleted Restrictions on AAT141 (Thermocouple Input) Installation
 - Deleted Installed position of AAT141 in cabinet (If node only)
 - Deleted Installed position of AAT141 in cabinet (If heat generating device exists)
 - Deleted Restrictions on the Installation of the Combination of AAT145 (Thermocouple Input) and Terminal Board AET4D
 - Deleted Installed position of AAT145 in cabinet (If heat generating device exists above the terminal boards)
 - Deleted Installed position of AAT145 in cabinet (If heat generating device exists under the terminal boards)
 - Deleted Limitations of Installation of Modules with Built-in Barrier
 - Deleted Limitations of Installation of Modules with Built-in Barrier Imposed by Capacity of Power Supply to Transmitters
 - Deleted Limitations of Installation for AST143 (the combination of thermocouple input and pressure clamp terminal)
5. Post-installation Inspection and Environmental Preservation
- Moved description of Floor Plans to External Dimensions (TI 33Q01J10-02E)
-

Oct.2004/8th Edition

1. System Installation Requirement
 - 1.2 Control Room Environment
 - Table of Equipment Installation Specification modified
 - 1.7 All of Non-Incendive Approval and parameter deleted.
For Non-Incendive, refer to TI33Q01J30-01E Explosion Protection.
 - 1.8 Corrosive-gas Environment Compatibility
 - G3 Environment-compatible Products
 - AFF50□ and AAP849 added to G3 Environment-compatible Products.
3. Cabling
 - 3.4 Power and Ground Cabling
 - Figure of Cabinet Cable Connection modified.
 - 3.6.2 List of Signal Cables for Connection with FIO
 - AAAP849 added to table.
 - 3.6.4 Implementation and Cable Connection of Fieldbus Communication Module ALF111
 - Figure of Connection of Fieldbus Communication Module ALF111 modified
4. Installation Specifications
 - AAP849 added to table of maximum power consumption of FIO
 - Paint Color Munsell Values Corrected.

Sep. 2005/9th Edition

1. System Installation Requirements
 - 1.2 Control Room Environment
 - Table Equipment Installation Specifications
 - YAX801 Temperature on normal operation separately specified
 - Humidity on normal operation and transportation/storage in case of AFF50□ newly specified
 - 1.6 Cabling Requirements
 - Measures against EMI added
2. Transportation, Storage and Installation
 - 2.5 Installation
 - 2.5.4 19-inch Rack Mount Devices
 - Instruction for device installation added
 - Model names of Optical Bus repeaters changed (YNT521□ YNT522□)
 - Attaching Brackets moved
 - Installation Direction added
3. Cabling
 - 3.6 Connecting Signal Cables with Fieldnetwork I/O(FIO)
 - 3.6.2 List of Signal Cables for Connection with FIO
 - JIS marks in "Table Signal Cables for Connection with FIO" deleted
4. Installation Specifications
 - Maximum Power Consumption of FIO
 - JIS marks in "Table Maximum Power Consumption of FIO" deleted

May 2007/10th Edition**1. System Installation Requirements****1.1 Control Room Design**

Clearance From The Wall and The Floor Surface

A desk (YAX101, YAX801) add.

1.2 Control Room Environment

Temperatures and Humidity

Description is modified.

Applied Standard

Standards for Hazardous Location Equipment

EN 50021:1999 of [Type n] is replaced with EN 60079-15:2003, IEC 60079-0:1998 and IEC 60079-11:1999.

[Non-Incendive] is replaced with [CSA Non-Incendive].

[FM Non-Incendive] add.

Installation Environment Specifications

Description about installation devices add.

YAX101 is added to "Table Equipment Installation Specifications (1/2)".

Description of "Table Equipment Installation Specifications (2/2)" is modified.

A general-purpose PC and PC is replaced with installation devices.

CSA C22.2 No.950, UL 1950 and EN 50082-1 of "Table Installation Environment Standard Used When a General-Purpose PC is Built in Console Kit" is replaced with CSA C22.2 No.60950, UL 60950 and EN 55024.

1.5.2 Countermeasures against Static Electricity

Figure of "Figure Example of Use of A Wrist Strap and Conductive Sheet" is modified.

1.7 Corrosive-gas Environment Compatibility

G3 Environment-compatible Products

Description of "Table G3 Environment-compatible Products " is modified.

2. Transportation, Storage and Installation**2.2 Unpacking**

Add IMPORTANT.

2.5.4 19-inch Rack Mount Devices

YNT521 is replaced with YNT522.

2.5.7 Installing Control Bus Interface Card

Description of "SEE ALSO" is modified.

3. Cabling**3.2 Connecting Power**

Type and Maximum Length of Power Cables

Description is modified.

Terminal Connection

YNT521 is replaced with YNT522.

3.4 Power and Ground Cabling

ANB10S/ANB10D ESB Bus Node Unit (19-inch Rack Mountable Type)

Example of Implementation and Cable Connection of 19-inch Rack Mount Devices add.

YNT511S/YNT511D, YNT522S/YNT522D Optical Bus Repeater

YNT521 is replaced with YNT522.

3.5 Connecting Signal Cable

Connecting Signal Cables to Terminals (for FIO)

"kgf•cm" of tightening torque is deleted.

FIO Node Unit Wiring in I/O Expansion Cabinet

ANR10S/ANR10D Wiring of 19-inch Rack Mountable Type Node Unit

Add figure.

3.6.3 Connecting Signal Cables with FIO

Connecting Signal Cables with Pulse Input Module AAP135

When Receiving No-Voltage Contact Signals (2)

Description is modified.

When Receiving Current Pulse By Using the Internal Power to Drive the Transmitter (2-wire power supply type)

"1k Ω " add.

3.8 Connecting Bus Cable

ESB Bus

"kgf•cm" of tightening torque is deleted.

4. Installation Specifications

Electrical Specifications

YNT521 is replaced with YNT522.

Actual Power-On In-Rush Current of Each Component

YNT521 is replaced with YNT522.

The content of "ACG10S Communication gateway unit" is modified.

Maximum Power Consumption of FIO

Description of "AAV542", "AAI135", "AAI835" and "AAP135" is modified.

Breaker Specifications

YNT521 is replaced with YNT522.

Parts Durability

Description of a resale product add.

Add IMPORTANT.

Operation and Monitoring Device (LPCKIT)

Description is modified. (A1096EM of a Fan unit delete, S9095FA of LCD unit is replaced with S9211FA.)

Description is modified.

Operation and Monitoring Device (YPCKIT)

Description is modified. (LCD unit (18 inch) delete, S9032FA and S9033FA of LCD unit is replaced with S9200FA and S9201FA, Operation keyboard is divided into 2, A1519 add.)

Control Devices (AFS10, AFG10 /AFS20, AFG20 /ACB21, ACB41/ANS50/AND50, ANS20/AND20)

A1096EM (Fan only) is deleted.

Description is modified.

Add LOPSVMK.

Add LOPXLMK.

Add AIP826/AIP827.

Control Devices (AFS10_, AFG10_/AFS20_, AFG20_/ACB21, ACB41/ANS50/AND50, ANS20/AND20)

Description is modified.

Control Devices (AFS30, AFG30 /AFS40, AFG40 /ANB10 /ANR10)

A1096EM (Fan only) is deleted.

Description is modified.

Control Devices(AFF50□).

Description is modified.

PFCS/PFCD Field Control Station.

Description is modified.

YNT511/YNT522 Optical Bus Repeater and YNT512 Bus Repeater. YNT521 is replaced with YNT522.

Bus Converter (ABC11S, ABC11D).

A1096EM (Fan only) is deleted.

Communication Gateway Unit (ACG10S)

Description is modified.

Oct 2007/11th Edition

1. System Installation Requirements

1.2 Control Room Environment

Applied Standards

Added the note of EMC Conformity Standard.

2. Transportation Storage and Installation

2.5.4 19-inch Rack Mount Devices

Isolation from Rack

Description of Installation to Rack is modified.

3. Cabling

3.10 Alarm and Contact I/O cabling

Status Contact Output Connection

Added MHM/MHC to Table Status Contact Output.

Sep.2008/12th Edition

Safety Precautions

Wiring I/O Cables [Changed the number CSA 1010 to CSA 61010]

1.1 Control Room Design

Side-by-Side Cabinet Installation [Revised the description]

1.2 Control Room Environment

Electric field strength (Electric ware condition) [Title changed and revised the description]

Safety Standards [Changed the CSA C22.2 number 1010.1 to 610101-04]

EMC Conformity Standards [Changed the AS/NZS number 2064 to CISPR 11]

Standards for Hazardous Location Equipment [Revised the description] [Changed EN and IEC number of Type n]

Installation Environment Specifications [Revised the Table]

1.4 Grounding

Enclosed Display Style Console Type HIS (LPCKIT) [Revised the figure of FCS]

2.5.4 19-inch Rack Mount Devices

Providing Space for Heat Radiation [Revised the description]

3.4 Power and Ground Cabling [Revised the figure of FCS]

3.5 Connecting Signal Cable

AFF50S/AFF50D,ANR10S/ANR10D Wiring [Added IMPORTANT and revised the figure]

FIO with KS Cable Interface Adapter Cabling [Revise the figure]

3.10 Alarm and Contact I/O Cabling [Changed the number CSA 1010 to CSA 61010]

4. Installation Specifications

YPCKIT [Revised the Table]

Feb. 2009 / 13th Edition

1. System Installation Requirement

1.2 Control Room Environment

Applied Standards [Revised the Standards Nnumber]

3. Cabling

3.4 Power and Ground Cabling

PFCS/PFCD Field Control Station [Revised the comment on figure]

YAX101 General-Purpose Desk [Revised the comment on figure]

YAX801 General-Purpose Desk [Revised the comment on figure]

3.8 Connecting Bus Cable

ER Bus [Added "ER Bus Converter Adapter"]

ER Bus [Added "10 Base-5 Cable"]

4. Installation Specifications

Parts Durability [Corrected]

Parts Durability [Revised the table title]

LOPSVMK [Changed the S9002KA and S9020KA to A1025EM and A1043EM]

Blank Page

Written by Yokogawa Electric Corporation

Published by Yokogawa Electric Corporation
2-9-32 Nakacho, Musashino-shi, Tokyo 180-8750, JAPAN

Printed by KOHOKU PUBLISHING & PRINTING INC.

Subject to change without notice.